

## Flash Code #6 - Inhibit Active

### Symptoms:

Battery condition meter LEDs scroll left to right.

### Diagnosis:

- An off-board charger is connected to the off-board charger socket (1a).
- There is a short between pin 2 and pin 3 of connector 1a.

### Solution:

If the VSI controller indicates an inhibit active fault and there is no off-board charger plugged into connector 1a, then replace the VSI controller (1) and retest the system.

## Flash Code #7 - Possible Joystick Fault

### Symptoms:

There are seven battery condition meter LEDs flashing.

### Diagnosis:

- The VSI controller has a problem with the joystick (gimble).
- The joystick was out of the neutral (center) position when powered up. The battery condition meter LEDs will ripple side-to-side twice, then display seven flashing LED's.

**NOTE:** If the battery condition meter is showing seven flashing LEDs, make sure there is no physical damage to the joystick keeping it from returning to the neutral (center) position.

### Solution:

Use the following procedure to find the source of the fault:

1. Turn the VSI off. Make sure the joystick is not being depressed in any direction.
  2. Turn the VSI back on.
- If the VSI still displays this fault, replace the VSI controller (1) and retest the system.

## Flash Code #8 - Possible Controller Fault

### Symptoms:

There are eight battery condition meter LEDs flashing.

### Diagnosis:

This is an indication that there is a problem with the VSI controller.

— If this fault occurs, replace the VSI controller (1) and retest the system.

## Flash Code #9 - Solenoid Brake Fault

### Symptoms:

Nine Battery Condition Meter LEDs Flashing

### Diagnosis:

There is an open on the motor brakes.

### Solution:

Use the following procedure to find the source of the fault:

1. Unplug connector 1c from connector 2a.
2. Measure resistance across pin 7 and pin 9 and across pin 8 and pin 9 on connector 2a. See figure 37.

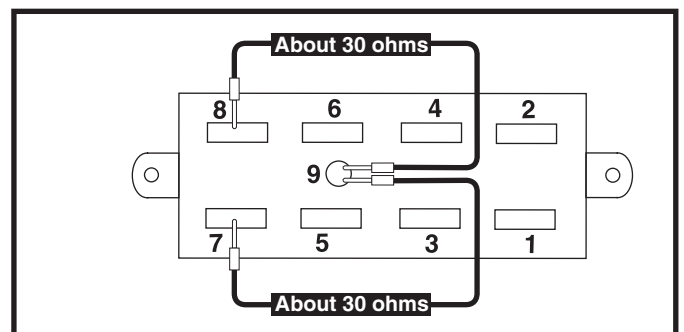

Figure 37. Connector 2a

- If your multimeter indicates about 30 ohms for either test, then replace the VSI controller (1) and retest the system.
  - If your multimeter does not indicate about 30 ohms for either test, then go to the next step.
3. Remove the seat and the foot platform assembly. Refer to the power base owner's manual.
  4. Remove the shroud. **See figure 38.**
  5. Unplug connector 2e from connector 8a and unplug connector 2d from connector 9a. **See diagram 2.**
  6. Measure resistance across pin 3 (white) and pin 4 (white) on connector 8a and across pin 3 (white) and pin 4 (white) on connector 9a. **See figure 39.**
- If your multimeter indicates about 60 ohms for both tests, then replace the power interface harness (2) and retest the system.
  - If your multimeter does not indicate about 60 ohms for both tests, then replace the corresponding brake assembly.

## Flash Code #10 - High Battery Voltage

### Symptoms:

There are ten battery condition meter LEDs flashing.

### Diagnosis:

The total battery voltage is over 32VDC. This only appears if the output of the charger is over 32VDC.

### Solution:

Use the following procedure to find the source of the fault:

**NOTE: Make sure the only chargers used on the Jazzy 1121 are Pride Mobility chargers. All of Pride's chargers are "smart chargers," this means when the batteries are fully charged the charger stops charging them. If a non-Pride charger was used, the batteries may be overcharged.**

1. Remove the seat and the foot platform assembly. Refer to the power base owner's manual.
  2. Remove the shroud. **See figure 38.**
  3. Plug the battery charger into a electrical outlet.
  4. Unplug connector 3b from connector 4b. **See diagram 2.**
  5. Measure voltage across pin 1 and pin 3 on connector 4a. **See figure 40.**
- If your multimeter indicates more than 30VDC, then replace the battery charger (4) and retest the system.

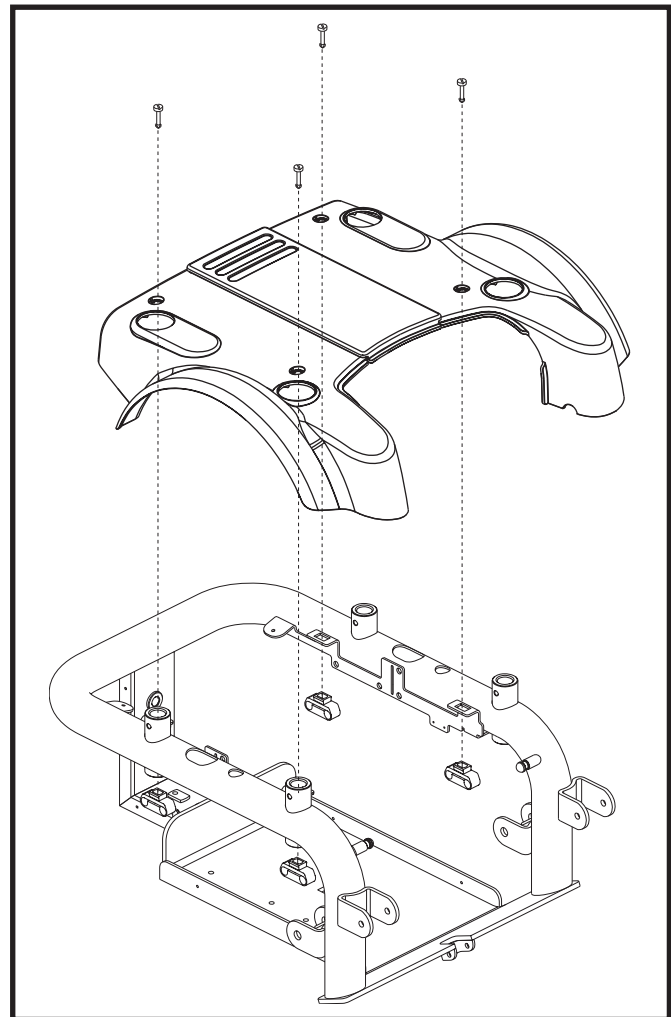

Figure 38. Jazzy 1121 Shroud Assembly/Disassembly

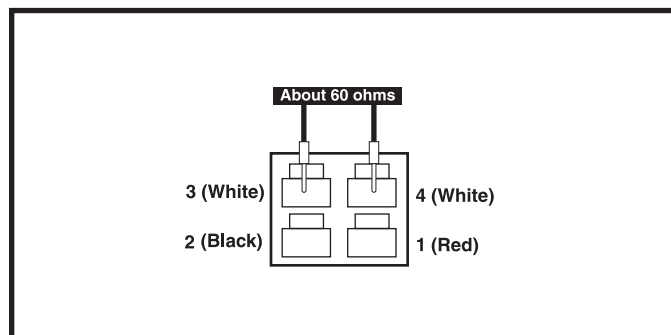

Figure 39. Connector 8a (also connector 9a)

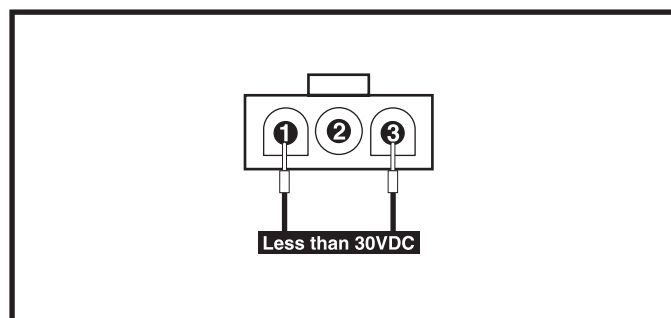

Figure 40. Connector 4a