

FOCUS *CR*

TECHNICAL MANUAL



This technical manual is designed to aid in the different procedures that may be needed for the Focus wheelchair. This technical manual does not replace, but aids the owner manual, adjustment guides and instructions. The procedures shown in this technical manual should only be performed by an Assistive Technology Practitioner (ATP) or clinical professional trained to do wheelchair repairs, adjustments and retrofits.

Additional information can be found in the Focus Owner Manual and Focus Adjustment Guides. The owner manual and adjustment guides can be found on the Ki Mobility website.

If you have any questions or concerns about any aspect of this wheelchair, this manual, or the service provided by us or your retail supplier, please do not hesitate to contact us by telephone at:

715-254-0991

In writing at:

Ki Mobility
5201 Woodward Drive
Stevens Point, WI 54481
U.S.A

Via email at:

sales@kimobility.com

Or via our Authorized EU Representative:

James Leckey Design
19C Ballinderry Road
Lisburn
BT28 2SA
Phone: 0800 318265 (UK) or 1800 626020 (ROI)
www.leckey.com



Table of Contents

Tools.....	3
Seat Height - Configuration Charts.....	4
Frame Setup by Depth Charts.....	25
Frame Setup Charts.....	27
Frame Depth for Backrest Offset.....	29
Seat Height - Axle Diagram References.....	30
Seat Height - Caster Arm Diagram References.....	32
Seat Height - Fork Diagram References.....	33
Caster Construction.....	34
Caster - Footplate Compatibility.....	34
Chair Width.....	39
Seat Depth.....	40
Tilt Mechanism Installation.....	41
Rotary Frame Replacement.....	52
Transit.....	63
Anti-Tips.....	64
Back Height.....	65
Backrest Angle Adjustment.....	67
Reclining Backrest.....	67
Seat Pan.....	68
Center of Gravity (COG).....	69
Caster Arm.....	71
Wheel Lock Configurations.....	72
Attendant Foot Lock.....	74
One Arm Drive.....	79
Drum Brake.....	82
Handrim Configurations.....	87
Handrim Construction.....	88
Footplate and Heel Loops.....	89
Rotating 4-Way Latch.....	90
Pro ELR Adjustment.....	91
Adjusting Height Adjustable T-Arm Position.....	91
Angle Adjustable Locking Flip Up Extendable Armrest.....	92
Bearing Construction.....	93
IV Holder.....	94
Vent and Battery Tray.....	95
Power Tilt Installation.....	100
Power Tilt Motor Replacement.....	108
Power Tilt Interface Control Box - Installation and Use.....	111
Contracture Footrest.....	117
Multi-Angle Footrest.....	121
Pediatric Pro ELR.....	123
Canopy.....	129

Tools

Please see the list below to identify the tools needed throughout this tech manual. Always check tools to ensure the ends are not stripped and that the tool can perform it's function properly without damaging any parts or hardware on the chair.

Tools Needed	
<ul style="list-style-type: none">• 2.5mm Allen Wrench	<ul style="list-style-type: none">• Two 8mm Wrenches
<ul style="list-style-type: none">• 3mm Allen Wrench	<ul style="list-style-type: none">• Two 10mm Wrenches
<ul style="list-style-type: none">• 4mm Allen Wrench	<ul style="list-style-type: none">• Two 13mm Wrenches
<ul style="list-style-type: none">• 5mm Allen Wrench	<ul style="list-style-type: none">• 17mm Wrench
<ul style="list-style-type: none">• 5.5mm Allen Wrench	<ul style="list-style-type: none">• 19mm Wrench
<ul style="list-style-type: none">• 6mm Allen Wrench	<ul style="list-style-type: none">• 30mm Wrench
<ul style="list-style-type: none">• Utility blade	<ul style="list-style-type: none">• Phillips Screwdriver

Seat Height - Configuration Charts

Select wheels and casters based on desired seat height. Make adjustment of axle sleeves (Page 30 & 31), caster arms (Page 32) and caster stems (Page 34) based on the subsequent sections. Subsequent sections define these activities and provide guidance for fastener locations.

Tire Type	Caster Size	Seat Height	Axle Sleeve	Caster Arm	Caster Fork	Caster Stem	Fork Hole
12" Pneumatic	5	13.5	Lo-5	Std	6"	Short	3
		14.5	Hi-5	Std	6"	Short	4
		14.5	Hi-5	Std	6"	Short	5
		17.5	Inv-1	Hi	6"	Short	4
		18	Inv-2	Hi	6"	Short	5
		18.5	Inv-3	Hi	6"	Tall	4
		19	Inv-4	Hi	6"	Tall	5
	19.5	Inv-5	Hi	6"	Tall	6	
	6	14.5	Hi-5	Std	6"	Short	4
		17.5	Inv-1	Hi	6"	Short	3
		18	Inv-2	Hi	6"	Short	4
		18.5	Inv-3	Hi	6"	Short	5
		19	Inv-4	Hi	6"	Tall	4
	19.5	Inv-5	Hi	6"	Tall	5	
	6X2	14.5	Hi-5	Std	6W	Short	2
		17.5	Inv-1	Hi	6W	Short	1
		18	Inv-2	Hi	6W	Short	2
		18.5	Inv-3	Hi	6W	Short	3
		19	Inv-4	Hi	6W	Tall	2
	19.5	Inv-5	Hi	6W	Tall	3	
	7	17.5	Inv-2	Std	7"	Tall	3
		18	Inv-3	Std	7"	Tall	4
		18.5	Inv-3	Hi	6"	Short	4
		19	Inv-4	Hi	6"	Short	5
		19.5	Inv-5	Hi	6"	Short	6
	8	17	Inv-1	Std	7"	Tall	1
		17.5	Inv-1	Std	7"	Tall	2
		18	Inv-2	Std	7"	Tall	3
		18.5	Inv-3	Std	7"	Tall	4
		19	Inv-4	Std	7"	Tall	5
	19.5	Inv-5	Hi	7W	Short	1	
	8X1.5	17.5	Inv-1	Std	7"	Tall	2
		18	Inv-2	Std	7"	Tall	3
		18.5	Inv-3	Std	7"	Tall	4
		19	Inv-4	Std	7"	Tall	5
19.5		Inv-5	Hi	7"	Short	2	
8X2	17.5	Inv-1	Std	7W	Tall	2	
	18	Inv-2	Std	7W	Tall	3	
	18.5	Inv-3	Std	7W	Tall	4	
	19	Inv-4	Std	7W	Tall	5	
	19.5	Inv-5	Hi	7W	Short	2	

Seat Height - Configuration Charts

Tire Type	Caster Size	Seat Height	Axle Sleeve	Caster Arm	Caster Fork	Caster Stem	Fork Hole	
12" Low Poly	5	16.5	Inv-1	Hi	5"	Short	2	
		17	Inv-2	Hi	5"	Short	3	
		17.5	Inv-3	Hi	6"	Short	4	
		18	Inv-4	Hi	6"	Short	5	
		18.5	Inv-5	Hi	6"	Short	6	
		19	Inv-5	Hi	7"	Short	3	
	6	16.5	Inv-1	Std	7"	7"	Tall	2
		17	Inv-2	Std	7"	7"	Tall	3
		17.5	Inv-2	Hi	6"	6"	Short	3
		18	Inv-3	Hi	6"	6"	Short	4
		18.5	Inv-4	Hi	6"	6"	Short	5
		19	Inv-5	Hi	6"	6"	Short	6
	6X2	16.5	Inv-1	Std	7W	7W	Tall	2
		17	Inv-2	Std	7W	7W	Tall	3
		17.5	Inv-3	Hi	6W	6W	Short	1
		18	Inv-4	Hi	6W	6W	Short	2
		18.5	Inv-5	Hi	6W	6W	Short	3
		19	Inv-5	Hi	6W	6W	Short	4
	7	16.5	Inv-1	Std	7"	7"	Short	3
		17	Inv-2	Std	7"	7"	Short	4
		17.5	Inv-3	Std	7"	7"	Tall	3
		18	Inv-4	Std	7"	7"	Tall	4
		18.5	Inv-5	Std	7"	7"	Tall	5
		19	Inv-5	Hi	7"	7"	Short	1
	8	16.5	Inv-1	Std	7"	7"	Short	2
		17	Inv-2	Std	7"	7"	Short	3
		17.5	Inv-3	Std	7"	7"	Tall	2
		18	Inv-4	Std	7"	7"	Tall	3
		18.5	Inv-5	Std	7"	7"	Tall	4
	8X1.5	16.5	Inv-1	Std	7"	7"	Short	3
		17	Inv-2	Std	7"	7"	Short	4
		17.5	Inv-2	Std	7"	7"	Tall	2
		18	Inv-3	Std	7"	7"	Tall	3
		18.5	Inv-4	Std	7"	7"	Tall	4
		19	Inv-5	Std	7"	7"	Tall	5
	8X2	17	Inv-2	Std	7W	7W	Tall	1
		17.5	Inv-3	Std	7W	7W	Tall	2
		18	Inv-4	Std	7W	7W	Tall	3
		18.5	Inv-5	Std	7W	7W	Tall	4

Seat Height - Configuration Charts

Tire Type	Caster Size	Seat Height	Axle Sleeve	Caster Arm	Caster Fork	Caster Stem	Fork Hole
16" Pneumatic	5	13	Lo-1	Std	5"	Short	2
		13.5	Lo-2	Std	5"	Short	3
		14	Hi-1	Std	6"	Short	4
		14.5	Hi-2	Std	6"	Short	5
		15	Hi-3	Std	6"	Short	6
		15.5	Hi-4	Std	6"	Tall	4
		16	Hi-5	Std	6"	Tall	5
		19	Inv-1	Hi	6"	Tall	5
		19.5	Inv-2	Hi	7"	Tall	2
		20	Inv-3	Hi	7"	Tall	3
	20.5	Inv-4	Hi	7"	Tall	4	
	6	14	Hi-1	Std	6"	Short	3
		14.5	Hi-2	Std	6"	Short	4
		15	Hi-3	Std	6"	Short	5
		15.5	Hi-3	Std	6"	Tall	3
		16	Hi-4	Std	6"	Tall	4
		16.5	Hi-5	Std	6"	Tall	5
		19	Inv-1	Hi	6"	Tall	4
		19.5	Inv-2	Hi	6"	Tall	5
	20	Inv-3	Hi	7"	Tall	2	
	20.5	Inv-4	Hi	7"	Tall	3	
	6X2	14	Hi-1	Std	6W	Short	1
		14.5	Hi-2	Std	6W	Short	2
		15	Hi-3	Std	6W	Short	3
		15.5	Hi-3	Std	6W	Tall	1
		16	Hi-4	Std	6W	Tall	2
		16.5	Hi-5	Std	6W	Tall	3
		19	Inv-1	Hi	6W	Tall	2
		19.5	Inv-2	Hi	6W	Tall	3
	20	Inv-2	Hi	7W	Short	4	
	20.5	Inv-3	Hi	7W	Short	5	
	7	15	Hi-3	Std	6"	Short	4
		15.5	Hi-4	Std	6"	Short	5
		16	Hi-5	Std	6"	Short	6
		19	Inv-1	Hi	6"	Short	5
		19.5	Inv-2	Hi	6"	Tall	4
		20	Inv-3	Hi	6"	Tall	5
	20.5	Inv-4	Hi	6"	Tall	6	
	8	16	Hi-5	Std	7"	Short	1
		19	Inv-1	Std	7"	Tall	5
		19.5	Inv-1	Hi	7"	Short	1
		20	Inv-2	Hi	7"	Short	2
	8X1.5	20.5	Inv-3	Hi	7"	Short	3
		15.5	Hi-4	Std	6"	Short	4
		16	Hi-5	Std	6"	Short	5
		19	Inv-1	Hi	7"	Short	1
		19.5	Inv-2	Hi	7"	Short	2
	20	Inv-3	Hi	7"	Short	3	
8X2	20.5	Inv-4	Hi	7"	Short	4	
	16	Hi-5	Std	7W	Short	1	
	19	Inv-1	Hi	7W	Short	1	
	19.5	Inv-2	Hi	7W	Short	2	
	20	Inv-3	Hi	7W	Short	3	
20.5	Inv-4	Hi	7W	Short	4		

Seat Height - Configuration Charts

Tire Type	Caster Size	Seat Height	Axle Sleeve	Caster Arm	Caster Fork	Caster Stem	Fork Hole
16" Poly	5	13	Lo-1	Std	5"	Short	2
		13.5	Lo-2	Std	5"	Short	3
		14	Hi-1	Std	6"	Short	4
		14.5	Hi-2	Std	6"	Short	5
		15	Hi-3	Std	6"	Short	6
		15.5	Hi-3	Std	6"	Tall	4
		16	Hi-4	Std	6"	Tall	5
		16.5	Hi-5	Std	6"	Tall	6
		19	Inv-1	Hi	6"	Tall	5
		19.5	Inv-2	Hi	7"	Tall	2
	20	Inv-3	Hi	7"	Tall	3	
	20.5	Inv-4	Hi	7"	Tall	4	
	6	14	Hi-1	Std	6"	Short	3
		14.5	Hi-2	Std	6"	Short	4
		15	Hi-3	Std	6"	Short	5
		15.5	Hi-3	Std	6"	Tall	3
		16	Hi-4	Std	6"	Tall	4
		16.5	Hi-5	Std	6"	Tall	5
		19	Inv-1	Hi	6"	Tall	4
		19.5	Inv-2	Hi	6"	Tall	5
	20	Inv-3	Hi	7"	Tall	2	
	20.5	Inv-4	Hi	7"	Tall	3	
	6X2	14	Hi-1	Std	6W	Short	1
		14.5	Hi-2	Std	6W	Short	2
		15	Hi-3	Std	6W	Short	3
		15.5	Hi-3	Std	6W	Tall	1
		16	Hi-4	Std	6W	Tall	2
		16.5	Hi-5	Std	6W	Tall	3
		19	Inv-1	Hi	6W	Tall	2
		19.5	Inv-2	Hi	6W	Tall	3
	20	Inv-2	Hi	7W	Short	4	
	20.5	Inv-3	Hi	7W	Short	5	
	7	15	Hi-3	Std	6"	Short	4
		15.5	Hi-4	Std	6"	Short	5
		16	Hi-5	Std	6"	Short	6
		16.5	Hi-5	Std	6"	Tall	4
		19.5	Inv-2	Hi	6"	Tall	4
		20	Inv-3	Hi	6"	Tall	5
	20.5	Inv-4	Hi	6"	Tall	6	
	8	16	Hi-4	Std	7"	Short	1
		19	Inv-1	Std	7"	Tall	5
		19.5	Inv-1	Hi	7"	Short	1
		20	Inv-2	Hi	7"	Short	2
		20.5	Inv-3	Hi	7"	Short	3
	8X1.5	15.5	Hi-3	Std	6"	Short	4
		16	Hi-4	Std	6"	Short	5
		16.5	Hi-5	Std	6"	Short	6
		19	Inv-1	Hi	7"	Short	1
		19.5	Inv-2	Hi	7"	Short	2
		20	Inv-3	Hi	7"	Short	3
8X2	20.5	Inv-4	Hi	7"	Short	4	
	16	Hi-4	Std	7"	Short	1	
	16.5	Hi-5	Std	7"	Short	2	
	19	Inv-1	Hi	7"	Short	1	
	19.5	Inv-2	Hi	7"	Short	2	
20	Inv-3	Hi	7"	Short	3		
20.5	Inv-4	Hi	7"	Short	4		

Seat Height - Configuration Charts

Tire Type	Caster Size	Seat Height	Axle Sleeve	Caster Arm	Caster Fork	Caster Stem	Fork Hole
16" Low Poly	5	13	Hi-1	Std	5"	Short	2
		13.5	Hi-2	Std	5"	Short	3
		14	Hi-3	Std	5"	Short	4
		14.5	Hi-4	Std	5"	Tall	2
		15	Hi-5	Std	5"	Tall	3
		18	Inv-1	Hi	6"	Tall	3
		18.5	Inv-2	Hi	6"	Tall	4
		19	Inv-3	Hi	6"	Tall	5
		19.5	Inv-3	Hi	7"	Short	5
	20	Inv-4	Hi	7"	Short	5	
	6	14	Hi-3	Std	6"	Short	3
		14.5	Hi-4	Std	6"	Short	4
		15	Hi-5	Std	6"	Short	5
		18	Inv-1	Hi	6"	Short	4
		18.5	Inv-2	Hi	6"	Short	5
		19	Inv-3	Hi	6"	Tall	4
		19.5	Inv-4	Hi	6"	Tall	5
	20	Inv-5	Hi	6"	Tall	6	
	6X2	14	Hi-3	Std	6W	Short	1
		14.5	Hi-4	Std	6W	Short	2
		15	Hi-5	Std	6W	Short	3
		18	Inv-1	Hi	6W	Short	2
		18.5	Inv-2	Hi	6W	Short	3
		19	Inv-2	Hi	7W	Short	2
		19.5	Inv-3	Hi	7W	Short	3
	20	Inv-4	Hi	7W	Short	4	
	20.5	Inv-5	Hi	7W	Short	5	
	7	18	Inv-1	Std	7"	Tall	4
		18.5	Inv-2	Std	7"	Tall	5
		19	Inv-2	Hi	7"	Short	1
		19.5	Inv-3	Hi	7"	Short	2
		20	Inv-4	Hi	7"	Short	3
	20.5	Inv-5	Hi	7"	Short	4	
	8	18	Inv-1	Std	7"	Tall	3
		18.5	Inv-2	Std	7"	Tall	4
		19	Inv-3	Std	7"	Tall	5
		19.5	Inv-3	Hi	7"	Short	1
		20	Inv-4	Hi	7"	Short	2
	20.5	Inv-5	Hi	7"	Short	3	
	8X1.5	18	Inv-1	Std	7"	Tall	3
		18.5	Inv-2	Std	7"	Tall	4
		19	Inv-3	Hi	7"	Short	1
19.5		Inv-4	Hi	7"	Short	2	
20		Inv-5	Hi	7"	Short	3	
8X2	18	Inv-1	Std	7W	Tall	3	
	18.5	Inv-2	Std	7W	Tall	4	
	19	Inv-3	Std	7W	Tall	5	
	19.5	Inv-4	Hi	7W	Short	2	
	20	Inv-5	Hi	7W	Short	3	

Seat Height - Configuration Charts

Tire Type	Caster Size	Seat Height	Axle Sleeve	Caster Arm	Caster Fork	Caster Stem	Fork Hole
16" Drum Brake	5	13.5	Hi-1	Std	5"	Short	3
		14	Hi-2	Std	6"	Short	4
		14.5	Hi-3	Std	6"	Short	5
		15	Hi-4	Std	6"	Short	6
		15.5	Hi-4	Std	6"	Tall	4
		16	Hi-5	Std	6"	Tall	5
		19	Inv-1	Hi	7"	Short	3
		19.5	Inv-2	Hi	7"	Short	4
		20	Inv-3	Hi	7"	Tall	3
	20.5	Inv-4	Hi	7"	Tall	4	
	6	14	Hi-2	Std	6"	Short	3
		14.5	Hi-3	Std	6"	Short	4
		15	Hi-4	Std	6"	Short	5
		15.5	Hi-4	Std	7"	Short	2
		16	Hi-5	Std	7"	Short	3
		18.5	Inv-1	Hi	6"	Tall	3
		19	Inv-2	Hi	6"	Tall	4
		19.5	Inv-3	Hi	6"	Tall	5
		20	Inv-3	Hi	7"	Tall	2
	20.5	Inv-4	Hi	7"	Tall	3	
	6X2	14	Hi-2	Std	6W	Short	1
		14.5	Hi-3	Std	6W	Short	2
		15	Hi-4	Std	6W	Short	3
		15.5	Hi-4	Std	7W	Short	2
		16	Hi-5	Std	7W	Short	3
		18.5	Inv-1	Hi	6W	Tall	1
		19	Inv-2	Hi	6W	Tall	2
		19.5	Inv-3	Hi	6W	Tall	3
	7	15	Hi-4	Std	6"	Short	4
		15.5	Hi-5	Std	6"	Short	5
		18.5	Inv-1	Std	7"	Tall	5
		19	Inv-1	Hi	7"	Short	1
		19.5	Inv-2	Hi	7"	Short	2
		20	Inv-3	Hi	7"	Short	3
		20.5	Inv-4	Hi	7"	Short	4
	8	18.5	Inv-1	Std	7"	Tall	4
		19	Inv-2	Std	7"	Tall	5
		19.5	Inv-2	Hi	7"	Short	1
		20	Inv-3	Hi	7"	Short	2
		20.5	Inv-4	Hi	7"	Short	3
8X1.5	15.5	Hi-4	Std	6"	Short	4	
	16	Hi-5	Std	6"	Short	5	
	18.5	Inv-1	Hi	6"	Short	4	
	19	Inv1	Hi	7"	Short	1	
	19.5	Inv-2	Hi	7"	Short	2	
	20	Inv-3	Hi	7"	Short	3	
8X2	20.5	Inv-4	Hi	7"	Short	4	
	16	Hi-5	Std	7W	Short	1	
	18.5	Inv-1	Std	7W	Tall	4	
	19	Inv-2	Hi	7W	Short	1	
	19.5	Inv-3	Hi	7W	Short	2	
	20	Inv-4	Hi	7W	Short	3	
20.5	Inv-5	Hi	7W	Short	4		

Seat Height - Configuration Charts

Tire Type	Caster Size	Seat Height	Axle Sleeve	Caster Arm	Caster Fork	Caster Stem	Fork Hole
20" Pneumatic	5	15	Lo-1	Std	6"	Short	6
		15.5	Lo-1	Std	6"	Tall	4
		16	Lo-2	Std	6"	Tall	5
		16.5	Hi-1	Hi	5"	Short	2
		17	Hi-2	Hi	5"	Short	3
		17.5	Hi-3	Hi	6"	Short	4
		18	Hi-4	Hi	6"	Short	5
		18.5	Hi-5	Hi	6"	Short	6
	6	15	Lo-1	Std	6"	Short	5
		15.5	Lo-1	Std	6"	Tall	3
		16	Lo-2	Std	6"	Tall	4
		16.5	Hi-1	Std	6"	Tall	5
		17	Hi-3	Std	7"	Tall	3
		17.5	Hi-3	Hi	6"	Short	3
		18	Hi-4	Hi	6"	Short	4
	6X2	15	Lo-1	Std	6W	Short	3
		15.5	Lo-1	Std	6W	Tall	1
		16	Lo-2	Std	6W	Tall	2
		16.5	Hi-1	Std	6W	Tall	3
		17	Hi-3	Std	7W	Tall	3
		17.5	Hi-3	Hi	6W	Short	1
		18	Hi-4	Hi	6W	Short	2
	7	15	Lo-1	Std	6"	Short	4
		15.5	Lo-2	Std	6"	Short	5
		16	Lo-2	Std	7"	Short	2
		16.5	Hi-1	Std	7"	Short	3
		17	Hi-2	Std	7"	Short	4
		17.5	Hi-4	Std	7"	Tall	3
		18	Hi-5	Std	7"	Tall	4
	8	16	Lo-2	Std	7"	Short	1
		16.5	Hi-1	Std	7"	Short	2
		17	Hi-2	Std	7"	Short	3
		17.5	Hi-3	Std	7"	Short	4
		18	Hi-4	Std	7"	Short	5
	8X1.5	15.5	Lo-2	Std	7"	Short	1
		16	Hi-1	Std	7"	Short	2
		16.5	Hi-2	Std	7"	Short	3
		17	Hi-3	Std	7"	Short	4
		17.5	Hi-3	Std	7"	Tall	2
		18	Hi-4	Std	7"	Tall	3
		18.5	Hi-5	Std	7"	Tall	4
	8X2	16	Lo-2	Std	7W	Short	1
16.5		Hi-1	Std	7W	Short	2	
17		Hi-2	Std	7W	Short	3	
17.5		Hi-3	Std	7W	Short	4	
18		Hi-4	Std	7W	Short	5	

Seat Height - Configuration Charts

Tire Type	Caster Size	Seat Height	Axle Sleeve	Caster Arm	Caster Fork	Caster Stem	Fork Hole
20" Poly	5	15	Lo-1	Std	6"	Short	6
		15.5	Lo-1	Std	6"	Tall	4
		16	Lo-2	Std	6"	Tall	5
		16.5	Hi-1	Hi	5"	Short	2
		17	Hi-2	Hi	5"	Short	3
		17.5	Hi-3	Hi	6"	Short	4
		18	Hi-4	Hi	6"	Short	5
		18.5	Hi-5	Hi	6"	Short	6
	6	15	Lo-1	Std	6"	Short	5
		15.5	Lo-1	Std	6"	Tall	3
		16	Lo-2	Std	6"	Tall	4
		16.5	Hi-1	Std	6"	Tall	5
		17	Hi-3	Std	7"	Tall	3
		17.5	Hi-3	Hi	6"	Short	3
		18	Hi-4	Hi	6"	Short	4
	6X2	15	Lo-1	Std	6W	Short	3
		15.5	Lo-1	Std	6W	Tall	1
		16	Lo-2	Std	6W	Tall	2
		16.5	Hi-1	Std	6W	Tall	3
		17	Hi-3	Std	7W	Tall	3
		17.5	Hi-3	Hi	6W	Short	1
		18	Hi-4	Hi	6W	Short	2
	7	15	Lo-1	Std	6"	Short	4
		15.5	Lo-2	Std	6"	Short	5
		16	Lo-2	Std	7"	Short	2
		16.5	Hi-1	Std	7"	Short	3
		17	Hi-2	Std	7"	Short	4
		17.5	Hi-4	Std	7"	Tall	3
		18	Hi-5	Std	7"	Tall	4
	8	16	Lo-2	Std	7"	Short	1
		16.5	Hi-1	Std	7"	Short	2
		17	Hi-2	Std	7"	Short	3
		17.5	Hi-3	Std	7"	Short	4
		18	Hi-4	Std	7"	Short	5
	8X1.5	15.5	Lo-2	Std	7"	Short	1
		16	Hi-1	Std	7"	Short	2
		16.5	Hi-2	Std	7"	Short	3
		17	Hi-3	Std	7"	Short	4
		17.5	Hi-4	Std	7"	Tall	2
		18	Hi-5	Std	7"	Tall	3
8X2	16	Lo-2	Std	7W	Short	1	
	16.5	Hi-1	Std	7W	Short	2	
	17	Hi-2	Std	7W	Short	3	
	17.5	Hi-3	Std	7W	Short	4	
	18	Hi-4	Std	7W	Short	5	

Seat Height - Configuration Charts

Tire Type	Caster Size	Seat Height	Axle Sleeve	Caster Arm	Caster Fork	Caster Stem	Fork Hole
22" Pneumatic	5	16	Lo-1	Std	7"	Tall	2
		16.5	Lo-1	Hi	5"	Short	2
		17	Lo-2	Hi	5"	Short	3
		17.5	Hi-1	Hi	6"	Short	4
		18	Hi-2	Hi	6"	Short	5
		18.5	Hi-4	Hi	6"	Tall	4
		19	Hi-5	Hi	6"	Tall	5
	6	19.5	Hi-5	Hi	7"	Short	4
		16	Lo-1	Std	7"	Tall	1
		16.5	Lo-2	Std	7"	Tall	2
		17	Hi-1	Std	7"	Tall	3
		17.5	Hi-1	Hi	6"	Short	3
		18	Hi-2	Hi	6"	Short	4
		18.5	Hi-3	Hi	6"	Short	5
	6X2	19	Hi-4	Hi	7"	Short	2
		19.5	Hi-5	Hi	7"	Short	3
		16	Lo-1	Std	7W	Tall	1
		16.5	Lo-2	Std	7W	Tall	2
		17	Hi-1	Std	7W	Tall	3
		17.5	Hi-1	Hi	6W	Short	1
		18	Hi-2	Hi	6W	Short	2
	7	18.5	Hi-3	Hi	6W	Short	3
		19	Hi-4	Hi	7W	Short	2
		19.5	Hi-5	Hi	7W	Short	3
		16	Lo-1	Std	7"	Short	2
		16.5	Lo-2	Std	7"	Short	3
		17	Hi-1	Std	7"	Short	4
		17.5	Hi-2	Std	7"	Tall	3
		18	Hi-3	Std	7"	Tall	4
		18.5	Hi-4	Hi	6"	Short	4
		19	Hi-5	Hi	6"	Short	5
	8	19.5	Hi-5	Hi	7"	Short	2
		16	Lo-1	Std	7"	Short	1
		16.5	Lo-1	Std	7"	Short	2
		17	Lo-2	Std	7"	Short	3
		17.5	Hi-1	Std	7"	Short	4
		18	Hi-3	Std	7"	Tall	3
		18.5	Hi-4	Std	7"	Tall	4
	8X1.5	19	Hi-5	Std	7"	Tall	5
		19.5	Hi-5	Hi	7"	Short	1
		16	Lo-1	Std	7"	Short	2
		16.5	Lo-2	Std	7"	Short	3
		17	Hi-1	Std	7"	Short	4
		17.5	Hi-1	Std	7"	Tall	2
		18	Hi-2	Std	7"	Tall	3
	8X2	18.5	Hi-3	Std	7"	Tall	4
		19	Hi-4	Std	7"	Tall	5
		19.5	Hi-5	Hi	7"	Short	1
		16.5	Lo-1	Std	7W	Short	2
		17	Lo-2	Std	7W	Short	3
	17.5	Hi-1	Std	7W	Short	4	
	18	Hi-3	Std	7W	Tall	3	
	18.5	Hi-4	Std	7W	Tall	4	
	19	Hi-5	Std	7W	Tall	5	

Seat Height - Configuration Charts

Tire Type	Caster Size	Seat Height	Axle Sleeve	Caster Arm	Caster Fork	Caster Stem	Fork Hole
22" Poly	5	16	Lo-1	Std	7"	Tall	2
		16.5	Lo-2	Hi	5"	Short	2
		17	Hi-1	Hi	5"	Short	3
		17.5	Hi-2	Hi	6"	Short	4
		18	Hi-3	Hi	6"	Short	5
		18.5	Hi-4	Hi	6"	Tall	4
		19	Hi-5	Hi	6"	Tall	5
	6	19.5	Hi-5	Hi	7"	Short	4
		16	Lo-1	Std	7"	Tall	1
		16.5	Lo-2	Std	7"	Tall	2
		17	Hi-1	Std	7"	Tall	3
		17.5	Hi-1	Hi	6"	Short	3
		18	Hi-2	Hi	6"	Short	4
		18.5	Hi-3	Hi	6"	Short	5
	6X2	19	Hi-4	Hi	7"	Short	2
		19.5	Hi-5	Hi	7"	Short	3
		16	Lo-1	Std	7W	Tall	1
		16.5	Lo-2	Std	7W	Tall	2
		17	Hi-1	Std	7W	Tall	3
		17.5	Hi-2	Hi	6W	Short	1
		18	Hi-3	Hi	6W	Short	2
	7	18.5	Hi-4	Hi	6W	Short	3
		19	Hi-4	Hi	7W	Short	2
		19.5	Hi-5	Hi	7W	Short	3
		16	Lo-1	Std	7"	Short	2
		16.5	Lo-2	Std	7"	Short	3
		17	Hi-1	Std	7"	Short	4
		17.5	Hi-2	Std	7"	Tall	3
	8	18	Hi-3	Std	7"	Tall	4
		18.5	Hi-4	Hi	6"	Short	4
		19	Hi-5	Hi	6"	Short	5
		19.5	Hi-5	Hi	7"	Short	2
		16	Lo-1	Std	7"	Short	1
		16.5	Lo-2	Std	7"	Short	2
		17	Hi-1	Std	7"	Short	3
	8X1.5	17.5	Hi-2	Std	7"	Short	4
		18	Hi-3	Std	7"	Tall	3
		18.5	Hi-4	Std	7"	Tall	4
		19	Hi-5	Std	7"	Tall	4
		19.5	Hi-5	Hi	7"	Tall	5
		19.5	Hi-5	Hi	7"	Short	1
		8X2	16.5	Lo-1	Std	7W	Short
	17		Lo-2	Std	7W	Short	3
	17.5		Hi-1	Std	7W	Short	4
	18		Hi-3	Std	7W	Tall	3
	18.5		Hi-4	Std	7W	Tall	4
	19		Hi-5	Std	7W	Tall	5

Seat Height - Configuration Charts

Tire Type	Caster Size	Seat Height	Axle Sleeve	Caster Arm	Caster Fork	Caster Stem	Fork Hole
24" Mag Pneumatic	5	17	Lo-1	Hi	6"	Short	3
		17.5	Lo-2	Hi	6"	Short	4
		18	Hi-1	Hi	6"	Short	5
		18.5	Hi-2	Hi	6"	Tall	4
		19	Hi-3	Hi	6"	Tall	5
		19.5	Hi-4	Hi	6"	Tall	6
		20	Hi-5	Hi	7"	Tall	3
	6	17	Lo-1	Std	7"	Tall	3
		17.5	Lo-2	Hi	6"	Short	3
		18	Hi-1	Hi	6"	Short	4
		18.5	Hi-2	Hi	6"	Short	5
		19	Hi-3	Hi	6"	Tall	4
		19.5	Hi-4	Hi	6"	Tall	5
	6X2	17	Lo-1	Std	7W	Tall	3
		17.5	Lo-2	Hi	6W	Short	1
		18	Hi-1	Hi	6W	Short	2
		18.5	Hi-2	Hi	6W	Short	3
		19	Hi-3	Hi	6W	Tall	2
		19.5	Hi-4	Hi	6W	Tall	3
	7	20	Hi-5	Hi	6W	Tall	4
		17	Lo-1	Std	7"	Tall	1
		17.5	Hi-1	Std	7"	Tall	3
		18	Hi-2	Std	7"	Tall	4
		18.5	Hi-2	Hi	6"	Short	4
		19	Hi-3	Hi	6"	Short	5
		19.5	Hi-4	Hi	7"	Short	2
	8	20	Hi-5	Hi	7"	Short	3
		17	Lo-1	Std	7"	Tall	1
		17.5	Lo-2	Std	7"	Tall	2
		18	Hi-1	Std	7"	Tall	3
		18.5	Hi-2	Std	7"	Tall	4
		19	Hi-3	Std	7"	Tall	5
	8X1.5	19.5	Hi-4	Hi	7"	Short	1
		20	Hi-5	Hi	7"	Short	2
		17	Lo-1	Std	7"	Tall	1
		17.5	Lo-2	Std	7"	Tall	2
		18	Hi-1	Std	7"	Tall	3
		18.5	Hi-2	Std	7"	Tall	4
		19	Hi-3	Hi	7"	Short	1
	8X2	19.5	Hi-4	Hi	7"	Short	2
		20	Hi-5	Hi	7"	Short	3
		17	Lo-1	Std	7W	Tall	1
17.5		Lo-2	Std	7W	Tall	2	
18		Hi-1	Std	7W	Tall	3	
18.5		Hi-2	Std	7W	Tall	4	
19		Hi-3	Std	7W	Tall	5	
19.5	Hi-4	Hi	7W	Short	2		
20	Hi-5	Hi	7W	Short	3		

Seat Height - Configuration Charts

Tire Type	Caster Size	Seat Height	Axle Sleeve	Caster Arm	Caster Fork	Caster Stem	Fork Hole
24" Mag Poly	5	16.5	Lo-1	Std	7"	Tall	3
		17	Lo-1	Hi	6"	Short	3
		17.5	Lo-2	Hi	6"	Short	4
		18	Hi-1	Hi	6"	Short	5
		18.5	Hi-3	Hi	6"	Tall	4
		19	Hi-4	Hi	6"	Tall	5
		19.5	Hi-5	Hi	6"	Tall	6
		20	Hi-5	Hi	7"	Tall	3
	6	16.5	Lo-1	Std	7"	Tall	2
		17	Lo-2	Std	7"	Tall	3
		17.5	Lo-2	Hi	6"	Short	3
		18	Hi-1	Hi	6"	Short	4
		18.5	Hi-2	Hi	6"	Short	5
		19	Hi-4	Hi	6"	Tall	4
		19.5	Hi-5	Hi	6"	Tall	5
		20	Hi-5	Hi	7"	Tall	2
	6X2	16.5	Lo-1	Std	7W	Tall	2
		17	Lo-2	Std	7W	Tall	3
		17.5	Lo-2	Hi	6W	Short	1
		18	Hi-1	Hi	6W	Short	2
		18.5	Hi-2	Hi	6W	Short	3
		19	Hi-4	Hi	6W	Tall	2
		19.5	Hi-4	Hi	7W	Short	3
		20	Hi-5	Hi	7W	Short	4
	7	17	Lo-1	Std	7"	Tall	1
		17.5	Hi-1	Std	7"	Tall	3
		18	Hi-2	Std	7"	Tall	4
		18.5	Hi-2	Hi	6"	Short	4
		19	Hi-3	Hi	6"	Short	5
		19.5	Hi-4	Hi	7"	Short	2
		20	Hi-5	Hi	7"	Short	3
	8	17	Lo-2	Std	7"	Tall	1
		17.5	Hi-1	Std	7"	Tall	2
		18	Hi-2	Std	7"	Tall	3
		18.5	Hi-3	Std	7"	Tall	4
		19	Hi-4	Std	7"	Tall	5
		19.5	Hi-4	Hi	7"	Short	1
		20	Hi-5	Hi	7"	Short	2
	8X1.5	16.5	Lo-1	Std	6"	Tall	4
		17	Lo-1	Std	7"	Tall	1
		17.5	Lo-2	Std	7"	Tall	2
		18	Hi-1	Std	7"	Tall	3
		18.5	Hi-2	Std	7"	Tall	4
		19	Hi-3	Hi	7"	Short	1
		19.5	Hi-4	Hi	7"	Short	2
		20	Hi-5	Hi	7"	Short	3
	8X2	17	Lo-2	Std	7W	Tall	1
		17.5	Hi-1	Std	7W	Tall	2
		18	Hi-2	Std	7W	Tall	3
		18.5	Hi-3	Std	7W	Tall	4
19		Hi-4	Std	7W	Tall	5	
19.5		Hi-5	Hi	7W	Short	2	

Seat Height - Configuration Charts

Tire Type	Caster Size	Seat Height	Axle Sleeve	Caster Arm	Caster Fork	Caster Stem	Fork Hole
24" Spoke Pneumatic	5	17	Lo-1	Hi	6"	Short	3
		17.5	Lo-2	Hi	6"	Short	4
		18	Hi-1	Hi	6"	Short	5
		18.5	Hi-2	Hi	6"	Tall	4
		19	Hi-3	Hi	6"	Tall	5
		19.5	Hi-4	Hi	6"	Tall	6
		20	Hi-5	Hi	7"	Tall	3
	6	17	Lo-1	Std	7"	Tall	3
		17.5	Lo-2	Hi	6"	Short	3
		18	Hi-1	Hi	6"	Short	4
		18.5	Hi-2	Hi	6"	Short	5
		19	Hi-3	Hi	6"	Tall	4
		19.5	Hi-4	Hi	6"	Tall	5
	6X2	17	Lo-1	Std	7W	Tall	3
		17.5	Lo-2	Hi	6W	Short	1
		18	Hi-1	Hi	6W	Short	2
		18.5	Hi-2	Hi	6W	Short	3
		19	Hi-3	Hi	6W	Tall	2
		19.5	Hi-4	Hi	6W	Tall	3
	7	17	Lo-1	Std	7"	Tall	1
		17.5	Lo-2	Std	7"	Tall	3
		18	Hi-1	Std	7"	Tall	4
		18.5	Hi-2	Hi	6"	Short	4
		19	Hi-3	Hi	6"	Short	5
		19.5	Hi-4	Hi	7"	Short	2
	8	17	Lo-1	Std	7"	Short	3
		17.5	Lo-2	Std	7"	Short	2
		18	Hi-1	Std	7"	Tall	3
		18.5	Hi-2	Std	7"	Tall	4
		19	Hi-3	Std	7"	Tall	5
		19.5	Hi-4	Hi	7"	Short	1
	8X1.5	17	Lo-1	Std	7"	Short	2
		17.5	Lo-2	Std	7"	Tall	2
		18	Hi-1	Std	7"	Tall	3
		18.5	Hi-2	Std	7"	Tall	4
		19	Hi-3	Hi	7"	Short	1
		19.5	Hi-4	Hi	7"	Short	2
	8X2	17	Lo-1	Std	7W	Short	3
		17.5	Lo-2	Std	7W	Tall	2
		18	Hi-1	Std	7W	Tall	3
		18.5	Hi-2	Std	7W	Tall	4
		19	Hi-3	Std	7W	Tall	5
19.5		Hi-4	Hi	7W	Short	2	
	20	Hi-5	Hi	7W	Short	3	

Seat Height - Configuration Charts

Tire Type	Caster Size	Seat Height	Axle Sleeve	Caster Arm	Caster Fork	Caster Stem	Fork Hole
24" Spoke Poly	5	16.5	Lo-1	Hi	5"	Short	2
		17	Lo-2	Hi	6"	Short	3
		17.5	Lo-2	Hi	6"	Short	4
		18	Hi-1	Hi	6"	Short	5
		18.5	Hi-3	Hi	6"	Tall	4
		19	Hi-4	Hi	6"	Tall	5
		19.5	Hi-5	Hi	6"	Tall	6
		20	Hi-5	Hi	7"	Short	5
	6	16.5	Lo-1	Std	7"	Tall	2
		17	Lo-2	Std	7"	Tall	3
		17.5	Lo-2	Hi	6"	Short	3
		18	Hi-1	Hi	6"	Short	4
		18.5	Hi-2	Hi	6"	Short	5
		19	Hi-4	Hi	6"	Tall	4
		19.5	Hi-5	Hi	6"	Tall	5
	6X2	16.5	Lo-1	Std	7W	Tall	2
		17	Lo-2	Std	7W	Tall	3
		17.5	Hi-1	Hi	6W	Short	1
		18	Hi-1	Hi	6W	Short	2
		18.5	Hi-2	Hi	6W	Short	3
		19	Hi-3	Hi	7W	Short	2
		19.5	Hi-4	Hi	7W	Short	3
		20	Hi-5	Hi	7W	Short	4
	7	16.5	Lo-1	Std	7"	Short	3
		17	Lo-1	Std	7"	Tall	1
		17.5	Hi-1	Std	7"	Tall	3
		18	Hi-2	Std	7"	Tall	4
		18.5	Hi-3	Hi	6"	Short	4
		19	Hi-4	Hi	6"	Short	5
		19.5	Hi-4	Hi	7"	Short	2
		20	Hi-5	Hi	7"	Short	3
	8	17	Lo-2	Std	7"	Tall	1
		17.5	Hi-1	Std	7"	Tall	2
		18	Hi-2	Std	7"	Tall	3
		18.5	Hi-3	Std	7"	Tall	4
		19	Hi-4	Std	7"	Tall	5
		19.5	Hi-4	Hi	7"	Short	1
		20	Hi-5	Hi	7"	Short	2
	8X1.5	17	Lo-1	Std	7"	Tall	1
		17.5	Lo-2	Std	7"	Tall	2
		18	Hi-1	Std	7"	Tall	3
		18.5	Hi-2	Std	7"	Tall	4
		19	Hi-3	Hi	7"	Short	1
		19.5	Hi-4	Hi	7"	Short	2
		20	Hi-5	Hi	7"	Short	3
8X2	17	Lo-2	Std	7W	Tall	1	
	17.5	Hi-1	Std	7W	Tall	2	
	18	Hi-2	Std	7W	Tall	3	
	18.5	Hi-3	Std	7W	Tall	4	
	19	Hi-4	Std	7W	Tall	5	
	19.5	Hi-5	Hi	7W	Short	2	

Seat Height - Configuration Charts (Froglegs)

Tire Type	Caster Size	Seat Height	Axle Sleeve	Caster Arm	Caster Fork	Caster Stem	Fork Hole
12" Pneumatic	5	17.5	Inv-1	Std	Frog	Tall	3
		18.5	Inv-3	Hi	Frog	Short	1
		19	Inv-4	Hi	Frog	Short	2
		19.5	Inv-5	Hi	Frog	Short	3
	6	17.5	Inv-1	Std	Frog	Tall	2
		18	Inv-2	Std	Frog	Tall	3
		19	Inv-4	Hi	Frog	Short	1
		19.5	Inv-5	Hi	Frog	Short	2
	6X2	18	Inv-2	Std	Big Rig	Tall	2
		19	Inv-4	Hi	Big Rig	Short	1
	7	17.5	Inv-1	Std	Frog	Short	3
		18	Inv-2	Std	Frog	Tall	2
		18.5	Inv-3	Std	Frog	Tall	3
	8	18	Inv-2	Std	Frog	Short	3
		19	Inv-4	Std	Frog	Tall	3
	8X1.5	17.5	Inv-1	Std	Frog	Short	3
		18.5	Inv-3	Std	Frog	Tall	3
	8X2	17.5	Inv-1	Std	Big Rig	Short	2
		19	Inv-4	Std	Big Rig	Tall	2

Tire Type	Caster Size	Seat Height	Axle Sleeve	Caster Arm	Caster Fork	Caster Stem	Fork Hole
12" Poly	5	16.5	Inv-1	Std	Frog	Tall	1
		17	Inv-2	Std	Frog	Tall	2
		17.5	Inv-3	Std	Frog	Tall	3
		18.5	Inv-5	Hi	Frog	Short	1
	6	16.5	Inv-1	Std	Frog	Short	3
		17	Inv-1	Std	Frog	Tall	1
		17.5	Inv-2	Std	Frog	Tall	2
		18	Inv-3	Std	Frog	Tall	3
	6X2	16.5	Inv-1	Std	Big Rig	Short	2
		17	Inv-1	Std	Big Rig	Tall	1
		18	Inv-3	Std	Big Rig	Tall	2
	7	17	Inv-1	Std	Frog	Short	2
		17.5	Inv-2	Std	Frog	Short	3
		18	Inv-4	Std	Frog	Tall	2
	8	18.5	Inv-5	Std	Frog	Tall	3
		18	Inv-3	Std	Frog	Short	3
	8X1.5	17.5	Inv-3	Std	Frog	Short	2
		18.5	Inv-5	Std	Frog	Tall	2
	8X2	17.5	Inv-3	Std	Big Rig	Short	2
		19	Inv-5	Std	Big Rig	Tall	2

Seat Height - Configuration Charts (Frolegs)

Tire Type	Caster Size	Seat Height	Axle Sleeve	Caster Arm	Caster Fork	Caster Stem	Fork Hole
16" Pneumatic	5	15.5	Hi-4	Std	Frog	Short	1
		16	Hi-5	Std	Frog	Short	2
		19	Inv-1	Hi	Frog	Short	2
		19.5	Inv-2	Hi	Frog	Short	3
		20	Inv-2	Hi	Frog	Tall	1
		20.5	Inv-3	Hi	Frog	Tall	2
	6	15.5	Hi-4	Std	Frog	Short	1
		16	Hi-5	Std	Frog	Short	2
		19	Inv-1	Hi	Frog	Short	1
		19.5	Inv-2	Hi	Frog	Short	2
		20	Inv-3	Hi	Frog	Short	3
		20.5	Inv-3	Hi	Frog	Tall	1
	6X2	15.5	Hi-4	Std	Big Rig	Short	1
		19	Inv-1	Hi	Big Rig	Short	1
		20	Inv-3	Hi	Big Rig	Short	2
		20.5	Inv-3	Hi	Big Rig	Tall	1
	7	20	Inv-3	Hi	Frog	Short	2
		20.5	Inv-4	Hi	Frog	Short	3
8	19	Inv-1	Std	Frog	Tall	3	
8X1.5	N/A	N/A	N/A	N/A	N/A	N/A	
8X2	19	Inv-1	Std	Big Rig	Tall	2	

Tire Type	Caster Size	Seat Height	Axle Sleeve	Caster Arm	Caster Fork	Caster Stem	Fork Hole
16" Poly	5	15.5	Hi-3	Std	Frog	Short	1
		16	Hi-4	Std	Frog	Short	2
		16.5	Hi-5	Std	Frog	Short	3
		19	Inv-1	Hi	Frog	Short	2
		19.5	Inv-2	Hi	Frog	Short	3
		20	Inv-2	Hi	Frog	Tall	1
		20.5	Inv-3	Hi	Frog	Tall	2
	6	15.5	Hi-4	Std	Frog	Short	1
		16	Hi-5	Std	Frog	Short	2
		19	Inv-1	Hi	Frog	Short	1
		19.5	Inv-2	Hi	Frog	Short	2
		20	Inv-3	Hi	Frog	Short	3
		20.5	Inv-3	Hi	Frog	Tall	1
	6X2	15.5	Hi-4	Std	Big Rig	Short	1
		19	Inv-1	Hi	Big Rig	Short	1
		20	Inv-3	Hi	Big Rig	Short	2
		20.5	Inv-3	Hi	Big Rig	Tall	1
	7	20	Inv-3	Hi	Frog	Short	2
		20.5	Inv-4	Hi	Frog	Short	3
	8	19	Inv-1	Std	Frog	Tall	3
8X1.5	N/A	N/A	N/A	N/A	N/A	N/A	
8X2	N/A	N/A	N/A	N/A	N/A	N/A	

Seat Height - Configuration Charts (Frolegs)

Tire Type	Caster Size	Seat Height	Axle Sleeve	Caster Arm	Caster Fork	Caster Stem	Fork Hole
16" Low Poly	5	15.5	Hi-5	Std	Frog	Short	1
		18.5	Inv-2	Hi	Frog	Short	1
		19	Inv-3	Hi	Frog	Short	2
		19.5	Inv-4	Hi	Frog	Short	3
		20	Inv-4	Hi	Frog	Tall	1
		20.5	Inv-5	Hi	Frog	Tall	2
	6	18	Inv-1	Std	Frog	Tall	3
		19	Inv-3	Hi	Frog	Short	1
		19.5	Inv-4	Hi	Frog	Short	2
		20	Inv-5	Hi	Frog	Short	3
		20.5	Inv-5	Hi	Frog	Tall	1
	6X2	18	Inv-1	Std	Big Rig	Tall	2
		19	Inv-3	Hi	Big Rig	Short	1
		20	Inv-5	Hi	Big Rig	Short	2
		20.5	Inv-5	Hi	Big Rig	Tall	1
	7	18	Inv-1	Std	Frog	Tall	2
		18.5	Inv-2	Std	Frog	Tall	3
		20	Inv-5	Hi	Frog	Short	2
	8	19	Inv-3	Std	Frog	Tall	3
	8X1.5	18.5	Inv-1	Std	Frog	Tall	3
8X2	N/A	N/A	N/A	N/A	N/A	N/A	

Tire Type	Caster Size	Seat Height	Axle Sleeve	Caster Arm	Caster Fork	Caster Stem	Fork Hole
16" Drum Brake	5	15.5	Hi-4	Std	Frog	Short	1
		16	Hi-5	Std	Frog	Short	2
		18.5	Inv-1	Hi	Frog	Short	1
		19	Inv-2	Hi	Frog	Short	2
		19.5	Inv-3	Hi	Frog	Short	3
		20	Inv-3	Hi	Frog	Tall	1
		20.5	Inv-4	Hi	Frog	Tall	2
	6	15.5	Hi-5	Std	Frog	Short	1
		19	Inv-1	Hi	Frog	Short	1
		19.5	Inv-2	Hi	Frog	Short	2
		20	Inv-3	Hi	Frog	Short	3
		20.5	Inv-3	Hi	Frog	Tall	1
	6X2	15.5	Hi-5	Std	Big Rig	Short	1
		19	Inv-1	Hi	Big Rig	Short	1
		20	Inv-3	Hi	Big Rig	Short	2
		20.5	Inv-4	Hi	Big Rig	Tall	1
	7	20	Inv-4	Hi	Frog	Short	2
		20.5	Inv-5	Hi	Frog	Short	3
	8	19	Inv-1	Std	Frog	Tall	3
	8X1.5	18.5	Inv-2	Std	Frog	Tall	3
8X2	N/A	N/A	N/A	N/A	N/A	N/A	

Seat Height - Configuration Charts (Froglegs)

Tire Type	Caster Size	Seat Height	Axle Sleeve	Caster Arm	Caster Fork	Caster Stem	Fork Hole
20" Pneumatic	5	15.5	Lo-1	Std	Frog	Short	1
		16	Lo-2	Std	Frog	Short	2
		16.5	Hi-1	Std	Frog	Short	3
		17	Hi-2	Std	Frog	Tall	2
		17.5	Hi-3	Std	Frog	Tall	3
	6	15.5	Lo-2	Std	Frog	Short	1
		16	Hi-1	Std	Frog	Short	2
		16.5	Hi-2	Std	Frog	Short	3
		17	Hi-2	Std	Frog	Tall	1
		17.5	Hi-3	Std	Frog	Tall	2
	6X2	15.5	Lo-2	Std	Big Rig	Short	1
		16.5	Hi-2	Std	Big Rig	Short	2
		17	Hi-2	Std	Big Rig	Tall	1
		18	Hi-4	Std	Big Rig	Tall	2
	7	17	Hi-2	Std	Frog	Short	2
		17.5	Hi-3	Std	Frog	Short	3
		18	Hi-4	Std	Frog	Tall	2
		18.5	Hi-5	Std	Frog	Tall	3
	8	18	Hi-4	Std	Frog	Short	3
	8X1.5	17.5	Hi-3	Std	Frog	Short	3
8X2	17.5	Hi-4	Std	Big Rig	Short	2	

Tire Type	Caster Size	Seat Height	Axle Sleeve	Caster Arm	Caster Fork	Caster Stem	Fork Hole
20" Poly	5	15.5	Lo-1	Std	Frog	Short	1
		16	Lo-2	Std	Frog	Short	2
		16.5	Hi-1	Std	Frog	Short	3
		17	Hi-3	Std	Frog	Tall	2
		17.5	Hi-4	Std	Frog	Tall	3
	6	15.5	Lo-2	Std	Frog	Short	1
		16	Hi-1	Std	Frog	Short	2
		16.5	Hi-2	Std	Frog	Short	3
		17	Hi-3	Std	Frog	Tall	1
		17.5	Hi-4	Std	Frog	Tall	2
		18	Hi-5	Std	Frog	Tall	3
	6X2	15.5	Lo-2	Std	Big Rig	Short	1
		16.5	Hi-2	Std	Big Rig	Short	2
		17	Hi-3	Std	Big Rig	Tall	1
		18	Hi-5	Std	Big Rig	Tall	2
	7	17	Hi-2	Std	Frog	Short	2
		17.5	Hi-3	Std	Frog	Short	3
		18	Hi-5	Std	Frog	Tall	2
	8	18	Hi-4	Std	Frog	Short	3
	8X1.5	17.5	Hi-4	Std	Frog	Short	3
8X2	17.5	Hi-4	Std	Big Rig	Short	2	

Seat Height - Configuration Charts (Froglegs)

Tire Type	Caster Size	Seat Height	Axle Sleeve	Caster Arm	Caster Fork	Caster Stem	Fork Hole
22" Pneumatic	5	16.5	Lo-2	Std	Frog	Tall	1
		17	Hi-1	Std	Frog	Tall	2
		17.5	Hi-2	Std	Frog	Tall	3
		18.5	Hi-4	Hi	Frog	Short	1
		19	Hi-5	Hi	Frog	Short	2
	6	16	Lo-1	Std	Frog	Short	2
		16.5	Lo-2	Std	Frog	Short	3
		17	Lo-2	Std	Frog	Tall	1
		17.5	Hi-1	Std	Frog	Tall	2
		18	Hi-2	Std	Frog	Tall	3
	6X2	19	Hi-5	Hi	Frog	Short	1
		16.5	Lo-2	Std	Big Rig	Short	2
		17	Lo-2	Std	Big Rig	Tall	1
		18	Hi-2	Std	Big Rig	Tall	2
	7	19	Hi-5	Hi	Big Rig	Short	1
		17	Lo-2	Std	Frog	Short	2
		17.5	Hi-1	Std	Frog	Short	3
		18	Hi-3	Std	Frog	Tall	2
	8	18.5	Hi-4	Std	Frog	Tall	3
		18	Hi-2	Std	Frog	Short	3
		19	Hi-5	Std	Frog	Tall	3
	8X1.5	17.5	Hi-2	Std	Frog	Short	3
		18.5	Hi-4	Std	Frog	Tall	3
	8X2	17.5	Hi-2	Std	Big Rig	Short	2
19		Hi-4	Std	Big Rig	Tall	2	

Tire Type	Caster Size	Seat Height	Axle Sleeve	Caster Arm	Caster Fork	Caster Stem	Fork Hole
22" Poly	5	16.5	Lo-2	Std	Frog	Tall	1
		17	Hi-1	Std	Frog	Tall	2
		17.5	Hi-2	Std	Frog	Tall	3
		18.5	Hi-4	Hi	Frog	Short	1
		19	Hi-5	Hi	Frog	Short	2
	6	16	Lo-1	Std	Frog	Short	2
		16.5	Lo-2	Std	Frog	Short	3
		17	Hi-1	Std	Frog	Tall	1
		17.5	Hi-2	Std	Frog	Tall	2
		18	Hi-3	Std	Frog	Tall	3
	6X2	19	Hi-5	Hi	Frog	Short	1
		16.5	Lo-2	Std	Big Rig	Short	2
		17	Hi-1	Std	Big Rig	Tall	1
		18	Hi-4	Std	Big Rig	Tall	2
	7	19	Hi-5	Hi	Big Rig	Short	1
		17	Lo-2	Std	Frog	Short	2
		17.5	Hi-1	Std	Frog	Short	3
		18	Hi-3	Std	Frog	Tall	2
	8	18.5	Hi-4	Std	Frog	Tall	3
		18	Hi-2	Std	Frog	Short	3
		19	Hi-5	Std	Frog	Tall	3
	8X1.5	17.5	Hi-2	Std	Frog	Short	3
		18.5	Hi-4	Std	Frog	Tall	3
	8X2	17.5	Hi-2	Std	Big Rig	Short	2
19		Hi-4	Std	Big Rig	Tall	2	

Seat Height - Configuration Charts (Froglegs)

Tire Type	Caster Size	Seat Height	Axle Sleeve	Caster Arm	Caster Fork	Caster Stem	Fork Hole	
24" Mag Pneumatic	5	17	Lo-1	Std	Frog	Tall	2	
		17.5	Lo-2	Std	Frog	Tall	3	
		18.5	Hi-2	Hi	Frog	Short	1	
		19	Hi-3	Hi	Frog	Short	2	
		19.5	Hi-4	Hi	Frog	Short	3	
	6	20	Hi-5	Hi	Frog	Tall	1	
		17	Lo-1	Std	Frog	Tall	1	
		17.5	Lo-2	Std	Frog	Tall	2	
		18	Hi-1	Std	Frog	Tall	3	
		19	Hi-3	Hi	Frog	Short	1	
	6X2	19.5	Hi-4	Hi	Frog	Short	2	
		20	Hi-5	Hi	Frog	Short	3	
		17	Lo-1	Std	Big Rig	Tall	1	
		18	Hi-1	Std	Big Rig	Tall	2	
		19	Hi-3	Hi	Big Rig	Short	1	
	7	20	Hi-5	Hi	Big Rig	Short	2	
		17	Lo-1	Std	Frog	Short	2	
		17.5	Lo-2	Std	Frog	Short	3	
		18	Hi-1	Std	Frog	Tall	2	
		18.5	Hi-2	Std	Frog	Tall	3	
	8	20	Hi-5	Hi	Frog	Short	2	
		18	Hi-1	Std	Frog	Short	3	
	8X1.5	19	Hi-3	Std	Frog	Tall	3	
		17.5	Lo-2	Std	Frog	Short	3	
	8X2	18.5	Hi-3	Std	Frog	Tall	3	
		17.5	Lo-2	Std	Big Rig	Short	2	
			19	Hi-3	Std	Big Rig	Tall	2

Tire Type	Caster Size	Seat Height	Axle Sleeve	Caster Arm	Caster Fork	Caster Stem	Fork Hole	
24" Mag Poly	5	17	Lo-1	Std	Frog	Tall	2	
		17.5	Lo-2	Std	Frog	Tall	3	
		18.5	Hi-3	Hi	Frog	Short	1	
		19	Hi-4	Hi	Frog	Short	2	
		19.5	Hi-5	Hi	Frog	Short	3	
	6	20	Hi-5	Hi	Frog	Tall	1	
		16.5	Lo-1	Std	Frog	Short	3	
		17	Lo-1	Std	Frog	Tall	1	
		17.5	Lo-2	Std	Frog	Tall	2	
		18	Hi-1	Std	Frog	Tall	3	
	6X2	19	Hi-3	Hi	Frog	Short	1	
		19.5	Hi-4	Hi	Frog	Short	2	
		20	Hi-5	Hi	Frog	Short	3	
		16.5	Lo-1	Std	Big Rig	Short	2	
		17	Lo-1	Std	Big Rig	Tall	1	
	7	18	Hi-1	Std	Big Rig	Tall	2	
		19	Hi-3	Hi	Big Rig	Short	1	
		20	Hi-5	Hi	Big Rig	Short	2	
		17	Lo-1	Std	Frog	Short	2	
		17.5	Lo-2	Std	Frog	Short	3	
	8	18	Hi-1	Std	Frog	Tall	2	
		18.5	Hi-2	Std	Frog	Tall	3	
	8X1.5	18	Hi-1	Std	Frog	Short	3	
		19	Hi-3	Std	Frog	Tall	3	
	8X2	17.5	Lo-2	Std	Frog	Short	3	
		18.5	Hi-3	Std	Frog	Tall	3	
			17.5	Hi-1	Std	Big Rig	Short	2
			19	Hi-3	Std	Big Rig	Tall	2

Seat Height - Configuration Charts (Froglegs)

Tire Type	Caster Size	Seat Height	Axle Sleeve	Caster Arm	Caster Fork	Caster Stem	Fork Hole	
24" Spoke Pneumatic	5	17	Lo-1	Std	Frog	Tall	2	
		17.5	Lo-2	Std	Frog	Tall	3	
		18.5	Hi-2	Hi	Frog	Short	1	
		19	Hi-3	Hi	Frog	Short	2	
		19.5	Hi-4	Hi	Frog	Short	3	
	6	20	Hi-5	Hi	Frog	Tall	1	
		17	Lo-1	Std	Frog	Tall	1	
		17.5	Lo-2	Std	Frog	Tall	2	
		18	Hi-1	Std	Frog	Tall	3	
		19	Hi-3	Hi	Frog	Short	1	
	6X2	19.5	Hi-4	Hi	Frog	Short	2	
		20	Hi-5	Hi	Frog	Short	3	
		17	Lo-1	Std	Big Rig	Tall	1	
		18	Hi-1	Std	Big Rig	Tall	2	
		19	Hi-3	Hi	Big Rig	Short	1	
	7	20	Hi-5	Hi	Big Rig	Short	2	
		17	Lo-1	Std	Frog	Short	2	
		17.5	Lo-2	Std	Frog	Short	3	
		18	Hi-1	Std	Frog	Tall	2	
		18.5	Hi-2	Std	Frog	Tall	3	
	8	20	Hi-5	Hi	Frog	Short	2	
		18	Hi-1	Std	Frog	Short	3	
	8X1.5	19	Hi-3	Std	Frog	Tall	3	
		17.5	Lo-2	Std	Frog	Short	3	
	8X2	18.5	Hi-3	Std	Frog	Tall	3	
		17.5	Lo-2	Std	Big Rig	Short	2	
			19	Hi-3	Std	Big Rig	Tall	2

Tire Type	Caster Size	Seat Height	Axle Sleeve	Caster Arm	Caster Fork	Caster Stem	Fork Hole	
24" Spoke Poly	5	17	Lo-2	Std	Frog	Tall	2	
		17.5	Hi-1	Std	Frog	Tall	3	
		18.5	Hi-3	Hi	Frog	Short	1	
		19	Hi-4	Hi	Frog	Short	2	
		19.5	Hi-5	Hi	Frog	Short	3	
	6	20	Hi-5	Hi	Frog	Tall	1	
		16.5	Lo-1	Std	Frog	Short	3	
		17	Lo-1	Std	Frog	Tall	1	
		17.5	Lo-2	Std	Frog	Tall	2	
		18	Hi-1	Std	Frog	Tall	3	
	6X2	19	Hi-3	Hi	Frog	Short	1	
		19.5	Hi-4	Hi	Frog	Short	2	
		20	Hi-5	Hi	Frog	Short	3	
		16.5	Lo-1	Std	Big Rig	Short	2	
		17	Lo-1	Std	Big Rig	Tall	1	
	7	18	Hi-1	Std	Big Rig	Tall	2	
		19	Hi-3	Hi	Big Rig	Short	1	
		20	Hi-5	Hi	Frog	Short	2	
		17	Lo-1	Std	Frog	Short	2	
		17.5	Lo-2	Std	Frog	Short	3	
	8	18	Hi-1	Std	Frog	Tall	2	
		18.5	Hi-2	Std	Frog	Tall	3	
	8X1.5	19	Hi-3	Std	Frog	Short	3	
		18	Hi-1	Std	Frog	Short	3	
	8X2	17.5	Lo-2	Std	Frog	Short	3	
		18.5	Hi-3	Std	Frog	Tall	3	
			17.5	Lo-1	Std	Big Rig	Short	2
			19	Hi-3	Std	Big Rig	Tall	2

Frame Setup by Depth Charts

Order Form Input		Work Order Output						
Frame Depth (See Page 40)	Frame Width (See Page 39)	Seat Frame Position (See Page 70)	Caster Position (See Page 32)	Axle Plate Position (See Page 30 & 31)				
				Standard		Self-Propel	Battery	Recline
				High	Low			
14	14	F1	1	1	3	1	6	5
14	15	F1	1	1	3	1	6	5
14	16	F1	1	1	3	1	6	5
14	17	F1	1	1	3	1	6	5
14	18	F1	1	1	3	1	6	5
14	19	F1	1	1	3	1	5	5
14	20	F1	1	1	3	1	5	5
14	21	F1	1	1	3	1	5	5
14	22	F1	1	1	3	1	5	5
15	14	F2	1	1	3	1	6	5
15	15	F2	1	1	3	1	6	5
15	16	R2	1	1	3	1	6	5
15	17	R2	1	1	3	1	6	5
15	18	F1	1	2	3	2	6	6
15	19	F1	1	2	3	2	5	6
15	20	F1	1	2	3	2	5	6
15	21	F1	1	2	3	2	5	6
15	22	F1	1	2	3	2	5	6
16	14	F3	1	1	3	1	6	5
16	15	R3	1	1	3	1	6	5
16	16	R3	1	1	3	1	6	5
16	17	F2	1	2	3	2	6	6
16	18	F2	1	2	3	2	6	6
16	19	R2	1	2	3	2	5	6
16	20	R2	1	2	3	2	5	6
16	21	F1	1	3	3	3	5	7
16	22	F1	1	3	3	3	5	7
17	14	R4	2	1	3	1	6	5
17	15	R4	2	1	3	1	6	5
17	16	F3	1	2	3	2	6	6
17	17	F3	1	2	3	2	6	6
17	18	R3	1	2	3	2	6	6
17	19	R3	1	2	3	2	5	6
17	20	F2	1	3	3	3	5	7
17	21	F2	1	3	3	3	5	7
17	22	R2	1	3	3	3	5	7
18	14	R5**	3	1	3	1	6	5
18	15	F4**	2	2	3	2	6	6
18	16	F4**	2	2	3	2	6	6
18	17	R4	2	2	3	2	6	6
18	18	R4	2	2	3	2	6	6
18	19	F3	1	3	3	3	5	7
18	20	F3	1	3	3	3	5	7
18	21	R3	1	3	3	3	5	7
18	22	R3	1	3	3	3	5	7

** Use R4 if short seat frame is chosen.

Frame Setup by Depth Charts

Order Form Input		Work Order Output						
Frame Depth (See Page 40)	Frame Width (See Page 39)	Seat Frame Position (See Page 70)	Caster Position (See Page 32)	Axle Plate Position (See Page 30 & 31)				
				Standard		Self-Propel	Battery	Recline
				High	Low			
19	14	F5	3	2	3	2	6	6
19	15	F5	3	2	3	2	6	6
19	16	R5	3	2	3	2	6	6
19	17	R5	3	2	3	2	6	6
19	18	F4	2	3	3	3	6	7
19	19	F4	2	3	3	3	5	7
19	20	R4	2	3	3	3	5	7
19	21	R4	2	3	3	3	5	7
19	22	F3	1	4	4	4	5	8
20	14	F6***	4	2	3	2	6	6
20	15	R6	4	2	3	2	6	6
20	16	R6	4	2	3	2	6	6
20	17	F5	3	3	3	3	6	7
20	18	F5	3	3	3	3	6	7
20	19	R5	3	3	3	3	5	7
20	20	R5	3	3	3	3	5	7
20	21	F4	2	4	4	4	5	8
20	22	F4	2	4	4	4	5	8
21	14	R7	4	2	3	2	6	6
21	15	R7	4	2	3	2	6	6
21	16	F6	4	3	3	3	6	7
21	17	F6	4	3	3	3	6	7
21	18	R6	4	3	3	3	6	7
21	19	R6	4	3	3	3	5	7
21	20	F5	3	4	4	4	5	8
21	21	F5	3	4	4	4	5	8
21	22	R5	3	4	4	4	5	8
22	14	R8	4	2	3	2	6	6
22	15	F7	4	3	3	3	6	7
22	16	F7	4	3	3	3	6	7
22	17	R7	4	3	3	3	6	7
22	18	R7	4	3	3	3	6	7
22	19	F6	4	4	4	4	5	8
22	20	F6	4	4	4	4	5	8
22	21	R6	4	4	4	4	5	8
22	22	R6	4	4	4	4	5	8

*** Use R6 if medium seat frame is chosen.

Frame Setup Charts

Order Form Input		Work Order Output						
Seat Depth (See Page 40)	Frame Width (See Page 39)	Seat Frame Position (See Page 70)	Caster Position (See Page 32)	Axle Plate Position (See Page 30 & 31)				
				Standard		Self-Propel	Battery	Recline
				High	Low			
14	14	F1	1	1	3	1	6	5
14	15	F1	1	1	3	1	6	5
14	16	F1	1	1	3	1	6	5
14	17	F1	1	1	3	1	6	5
14	18	F1	1	1	3	1	6	5
14	19	F1	1	1	3	1	5	5
14	20	F1	1	1	3	1	5	5
14	21	F1	1	1	3	1	5	5
14	22	F1	1	1	3	1	5	5
15	14	F2	1	1	3	1	6	5
15	15	F2	1	1	3	1	6	5
15	16	R2	1	1	3	1	6	5
15	17	R2	1	1	3	1	6	5
15	18	F1	1	2	3	2	6	6
15	19	F1	1	2	3	2	5	6
15	20	F1	1	2	3	2	5	6
15	21	F1	1	2	3	2	5	6
15	22	F1	1	2	3	2	5	6
16	14	F3	1	1	3	1	6	5
16	15	R3	1	1	3	1	6	5
16	16	R3	1	1	3	1	6	5
16	17	F2	1	2	3	2	6	6
16	18	F2	1	2	3	2	6	6
16	19	R2	1	2	3	2	5	6
16	20	R2	1	2	3	2	5	6
16	21	F1	1	3	3	3	5	7
16	22	F1	1	3	3	3	5	7

Frame Setup Charts

Order Form Input		Work Order Output						
Seat Depth (See Page 40)	Frame Width (See Page 39)	Seat Frame Position (See Page 70)	Caster Position (See Page 32)	Axle Plate Position (See Page 30 & 31)				
				Standard		Self-Propel	Battery	Recline
				High	Low			
17	14	R4	2	1	3	1	6	5
17	15	R4	2	1	3	1	6	5
17	16	F3	1	2	3	2	6	6
17	17	F3	1	2	3	2	6	6
17	18	R3	1	2	3	2	6	6
17	19	R3	1	2	3	2	5	6
17	20	F2	1	3	3	3	5	7
17	21	F2	1	3	3	3	5	7
17	22	R2	1	3	3	3	5	7
18	14	R5	3	1	3	1	6	5
18	15	F4	2	2	3	2	6	6
18	16	F4	2	2	3	2	6	6
18	17	R4	2	2	3	2	6	6
18	18	R4	2	2	3	2	6	6
18	19	F3	1	3	3	3	5	7
18	20	F3	1	3	3	3	5	7
18	21	R3	1	3	3	3	5	7
18	22	R3	1	3	3	3	5	7
19	14	F5	3	2	3	2	6	6
19	15	F5	3	2	3	2	6	6
19	16	R5	3	2	3	2	6	6
19	17	R5	3	2	3	2	6	6
19	18	F4	2	3	3	3	6	7
19	19	F4	2	3	3	3	5	7
19	20	R4	2	3	3	3	5	7
19	21	R4	2	3	3	3	5	7
19	22	F3	1	4	4	4	5	8

Frame Setup Charts

Order Form Input		Work Order Output						
Seat Depth (See Page 40)	Frame Width (See Page 39)	Seat Frame Position (See Page 70)	Caster Position (See Page 32)	Axle Plate Position (See Page 30 & 31)				
				Standard		Self-Propel	Battery	Recline
				High	Low			
20	14	F6	4	2	3	2	6	6
20	15	R6	4	2	3	2	6	6
20	16	R6	4	2	3	2	6	6
20	17	F5	3	3	3	3	6	7
20	18	F5	3	3	3	3	6	7
20	19	R5	3	3	3	3	5	7
20	20	R5	3	3	3	3	5	7
20	21	F4	2	4	4	4	5	8
20	22	F4	2	4	4	4	5	8
21	14	R7	4	2	3	2	6	6
21	15	R7	4	2	3	2	6	6
21	16	F6	4	3	3	3	6	7
21	17	F6	4	3	3	3	6	7
21	18	R6	4	3	3	3	6	7
21	19	R6	4	3	3	3	5	7
21	20	F5	3	4	4	4	5	8
21	21	F5	3	4	4	4	5	8
21	22	R5	3	4	4	4	5	8
22	14	R8	4	2	3	2	6	6
22	15	F7	4	3	3	3	6	7
22	16	F7	4	3	3	3	6	7
22	17	R7	4	3	3	3	6	7
22	18	R7	4	3	3	3	6	7
22	19	F6	4	4	4	4	5	8
22	20	F6	4	4	4	4	5	8
22	21	R6	4	4	4	4	5	8
22	22	R6	4	4	4	4	5	8

Frame Depth for Backrest Offset

Seat Depth (See Page 40)	Frame Depth for Backrest Offset						
	-2	-1	0	+1	+2	+3	+4
14	N/A	N/A	14	15	16	17	18
15	N/A	14	15	16	17	18	19
16	14	15	16	17	18	19	20
17	15	16	17	18	19	20	21
18	16	17	18	19	20	21	22
19	17	18	19	20	21	22	N/A
20	18	19	20	21	22	N/A	N/A
21	19	20	21	22	N/A	N/A	N/A
22	20	21	22	N/A	N/A	N/A	N/A

Seat Height - Axle Diagram References

With the correct configuration determined from the charts above, use the diagrams below to identify parts and hole locations. See the next page for actual hardware and assembly instructions after identifying parts and hole locations.

Axle Sleeve

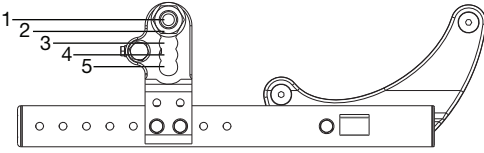

Low Range Configuration

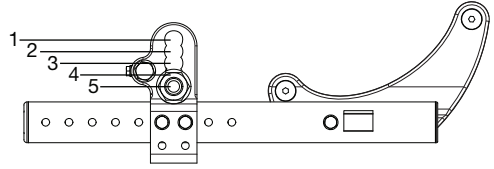

High Range Configuration

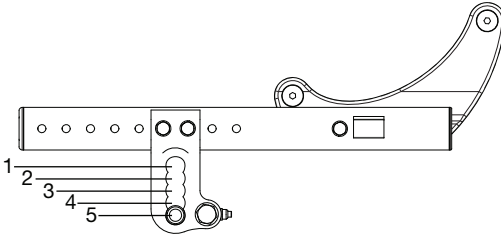

Inverted Configuration

Axle Plate Positioning

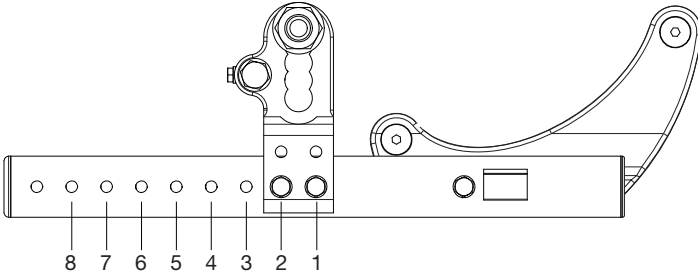

Axle Plate shown fully forward (Position 1).

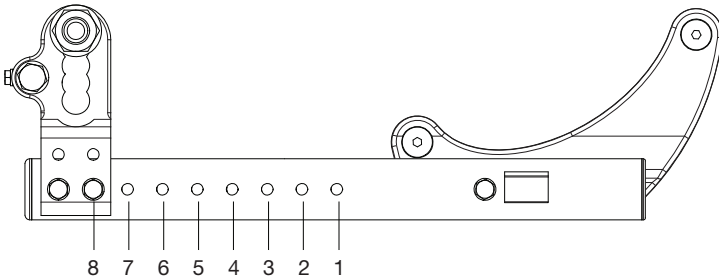

Axle Plate shown fully rearward (Position 8)

Seat Height - Axle Diagram References

See diagrams below for assembly details of the axle plate and inverted axle plate. The two lower bolts and nuts will need two 13mm wrenches. The two axle receiver nuts will need a 30mm wrench. The single top bolt needs a 19mm wrench.

Axle Plate Construction

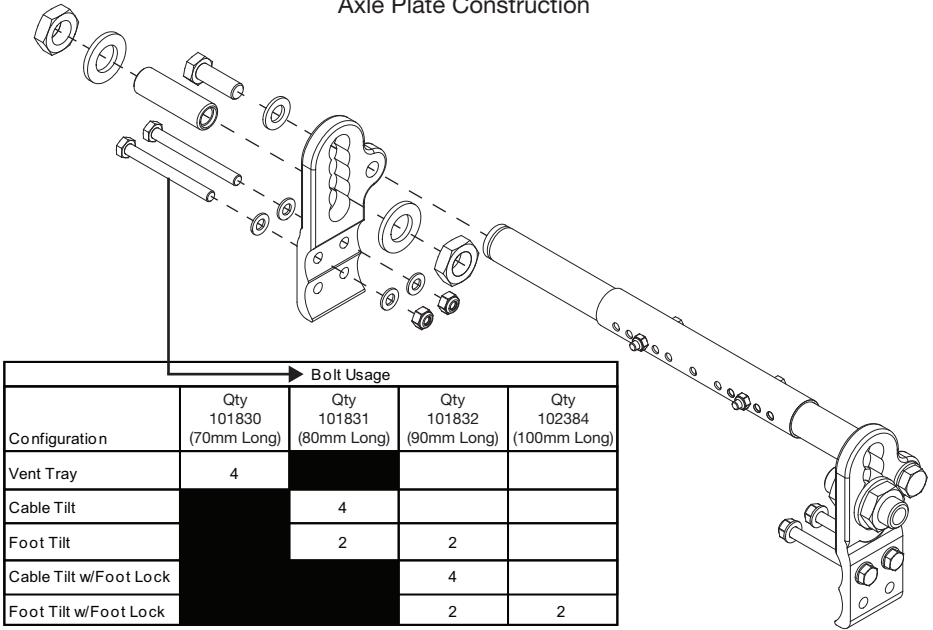

Inverted Axle Plate Construction

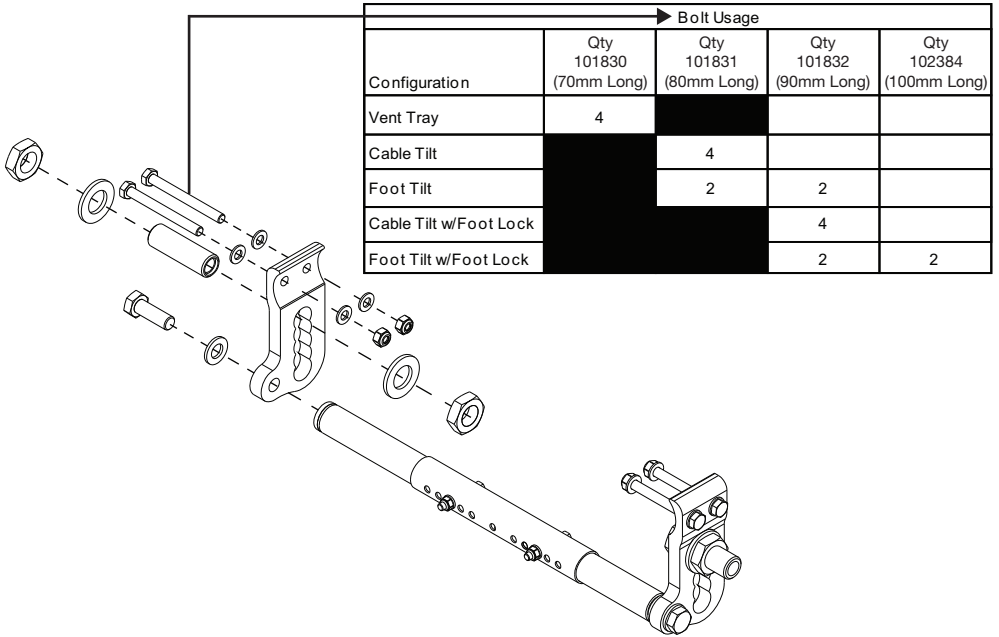

Seat Height - Caster Arm Diagram References

See below for diagrams of the caster arm diagram references. The CG position to caster arms position bolt called out below will need a 5mm Allen wrench. The caster arm holes, at the bottom of the graphic, use a bolt, washer and nut that require two 13mm wrenches.

Caster Arm

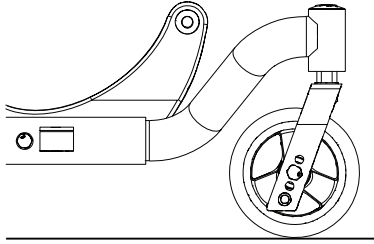

Standard

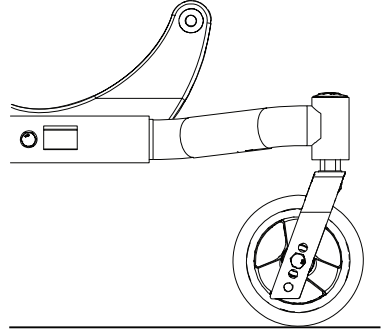

High

CG Position to Caster Arm Position	
Seat Frame Position	Caster Position
F1	1
F2	1
R2	1
F3	1
R3	1
F4	2
R4	2
F5	3
R5	3
F6	4
R6	4
F7	4
R7	4
R8	4

*Each hole on the frame represents a 1/2" increment. Moving two holes along the frame offers four bolt positions - front and back bolt locations x two frame holes.

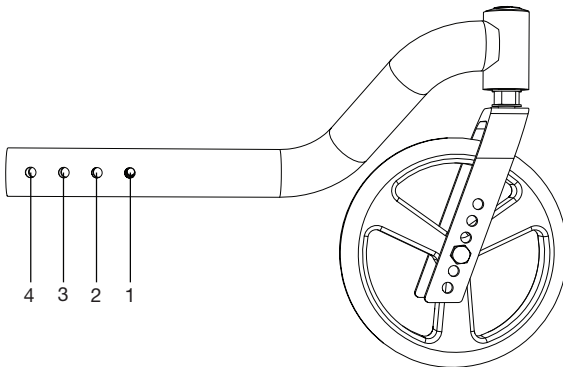
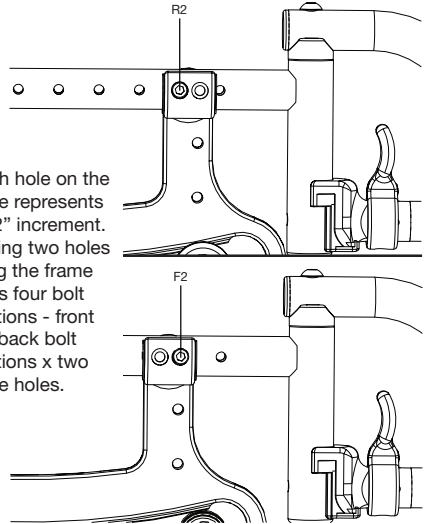

Seat Height - Fork Diagram References

Fork Size, Fork Hole Location and Stem Height

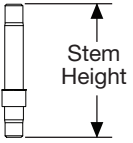

Standard	3.5"
Tall	4.8"

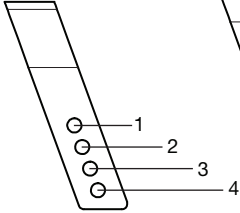

5" Fork

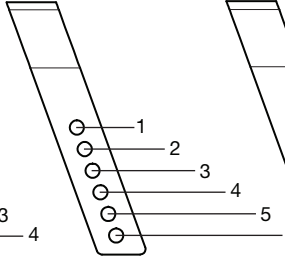

6" Fork

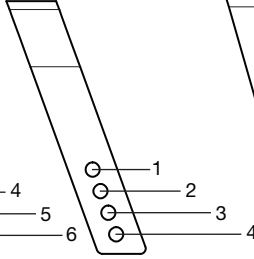

6" Wide Fork

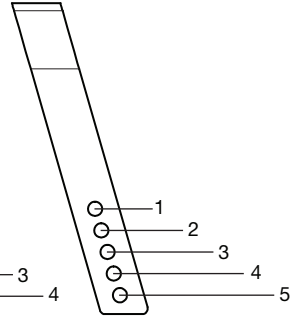

7" Standard &
Wide Fork

Caster Construction

Caster assemblies are shown below. Securing the caster wheel to the fork requires two 13mm wrenches. Securing the stem to the fork requires an 19mm wrench.

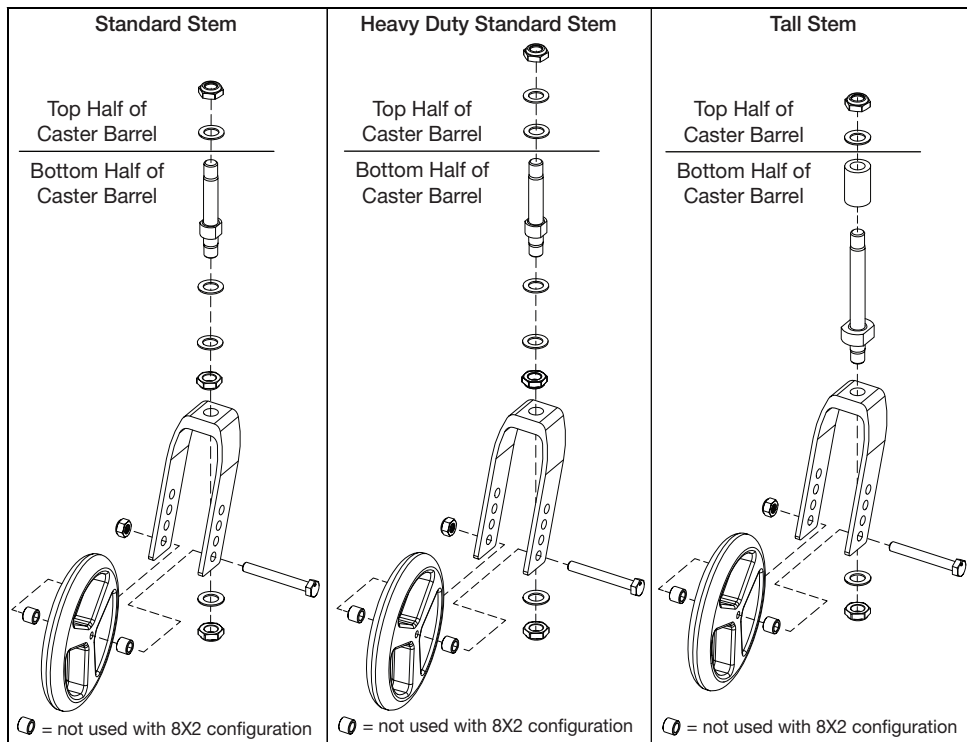

Caster - Footplate Compatibility

60° Extension Mount Hangers - Composite Footplate

Hanger Type	Standard Hanger						Offset Hanger																	
	5		6		6X2		7		8		8X2		5		6		6X2		7		8		8X2	
Degrees of Tilt	0	5	0	5	0	5	0	5	0	5	0	5	0	5	0	5	0	5	0	5	0	5	0	5
Seat to Floor Height	13																							
	13.5																							
	14																							
	14.5																							
	15																							
	15.5																							
	16																							
	16.5																							
	17																							
	17.5																							
	18																							
	18.5																							
	19																							
19.5																								

Caster - Footplate Compatibility

60° Extension Mount Hangers - Angle Adjustable Footplate

Hanger Type		Standard Hanger						Offset Hanger																			
Caster Size		5		6		6X2		7		8		8X2		5		6		6X2		7		8		8X2			
Degrees of Tilt		0	5	0	5	0	5	0	5	0	5	0	5	0	5	0	5	0	5	0	5	0	5	0	5	0	5
Seat to Floor Height	13																										
	13.5																										
	14																										
	14.5																										
	15																										
	15.5																										
	16																										
	16.5																										
	17																										
	17.5																										
	18																										
	18.5																										
	19																										
19.5																											

70° Extension Mount Hangers - Composite Footplate

Hanger Type		Standard Hanger						Offset Hanger																			
Caster Size		5		6		6X2		7		8		8X2		5		6		6X2		7		8		8X2			
Degrees of Tilt		0	5	0	5	0	5	0	5	0	5	0	5	0	5	0	5	0	5	0	5	0	5	0	5	0	5
Seat to Floor Height	13																										
	13.5																										
	14																										
	14.5																										
	15																										
	15.5																										
	16																										
	16.5																										
	17																										
	17.5																										
	18																										
	18.5																										
	19																										
19.5																											

Caster - Footplate Compatibility

70° Extension Mount Hangers - Angle Adjustable Footplate

Hanger Type		Standard Hanger						Offset Hanger																		
Caster Size		5		6		6X2		7		8		8X2		5		6		6X2		7		8		8X2		
Degrees of Tilt		0	5	0	5	0	5	0	5	0	5	0	5	0	5	0	5	0	5	0	5	0	5	0	5	
Seat to Floor Height	13																									
	13.5																									
	14																									
	14.5																									
	15																									
	15.5																									
	16																									
	16.5																									
	17																									
	17.5																									
	18																									
	18.5																									
	19																									
19.5																										

80° Extension Mount Hangers - Composite Footplate

Hanger Type		Standard Hanger						Offset Hanger																	
Caster Size		5		6		6X2		7		8		8X2		5		6		6X2		7		8		8X2	
Degrees of Tilt		0	5	0	5	0	5	0	5	0	5	0	5	0	5	0	5	0	5	0	5	0	5	0	5
Seat to Floor Height	13																								
	13.5																								
	14																								
	14.5																								
	15																								
	15.5																								
	16																								
	16.5																								
	17																								
	17.5																								
	18																								
	18.5																								
	19																								
19.5																									

Caster - Footplate Compatibility

80° Extension Mount Hangers - Angle Adjustable Footplate

Hanger Type		Standard Hanger						Offset Hanger																				
Caster Size		5		6		6X2		7		8		8X2		5		6		6X2		7		8		8X2				
Degrees of Tilt		0	5	0	5	0	5	0	5	0	5	0	5	0	5	0	5	0	5	0	5	0	5	0	5	0	5	
Seat to Floor Height	13																											
	13.5																											
	14																											
	14.5																											
	15																											
	15.5																											
	16																											
	16.5																											
	17																											
	17.5																											
	18																											
	18.5																											
	19																											
19.5																												

70° Front Mount Hangers - Angle Adjustable Footplate

Hanger Type		Standard Hanger						Offset Hanger																				
Caster Size		5		6		6X2		7		8		8X2		5		6		6X2		7		8		8X2				
Degrees of Tilt		0	5	0	5	0	5	0	5	0	5	0	5	0	5	0	5	0	5	0	5	0	5	0	5	0	5	
Seat to Floor Height	13																											
	13.5																											
	14																											
	14.5																											
	15																											
	15.5																											
	16																											
	16.5																											
	17																											
	17.5																											
	18																											
	18.5																											
	19																											
19.5																												

Caster - Footrest Compatibility

80° Front Mount Hangers - Angle Adjustable Footplate

Hanger Type		Standard Hanger												Offset Hanger											
Caster Size		5		6		6X2		7		8		8X2		5		6		6X2		7		8		8X2	
Degrees of Tilt		0	5	0	5	0	5	0	5	0	5	0	5	0	5	0	5	0	5	0	5	0	5	0	5
Seat to Floor Height	13																								
	13.5																								
	14																								
	14.5																								
	15																								
	15.5																								
	16																								
	16.5																								
	17																								
	17.5																								
	18																								
	18.5																								
	19																								
	19.5																								

90° Front Mount Hangers - Angle Adjustable Footplate

Hanger Type		Standard Hanger												Offset Hanger											
Caster Size		5		6		6X2		7		8		8X2		5		6		6X2		7		8		8X2	
Degrees of Tilt		0	5	0	5	0	5	0	5	0	5	0	5	0	5	0	5	0	5	0	5	0	5	0	5
Seat to Floor Height	13																								
	13.5																								
	14																								
	14.5																								
	15																								
	15.5																								
	16																								
	16.5																								
	17																								
	17.5																								
	18																								
	18.5																								
	19																								
	19.5																								

Chair Width

To adjust chair width, use two 8mm wrenches and two 10mm wrenches to remove the two sets of hardware on each strut tube. Reinstall hardware sets in new locations based on the diagram at the bottom of this page. For a horizontal tilt mechanism, an 8mm wrench is used to loosen the clamp and adjust the tilt lock tube.

NOTE: Each set of hardware must be located in the same hole on each strut tube. For example, the image below shows the sets using the center hole location on each strut tube (five holes on each side and bolt is in the third hole on both sides).

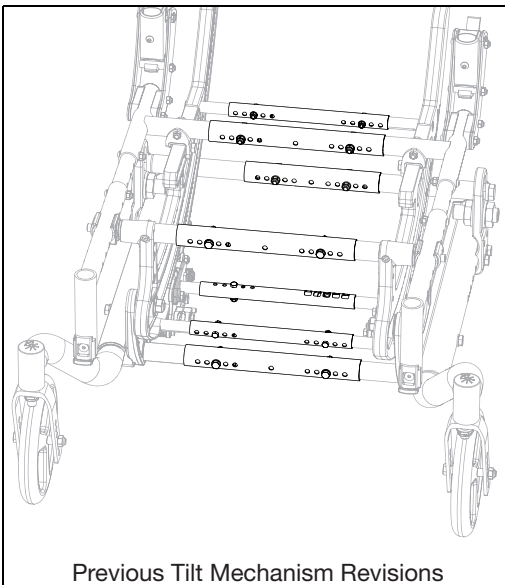

Previous Tilt Mechanism Revisions

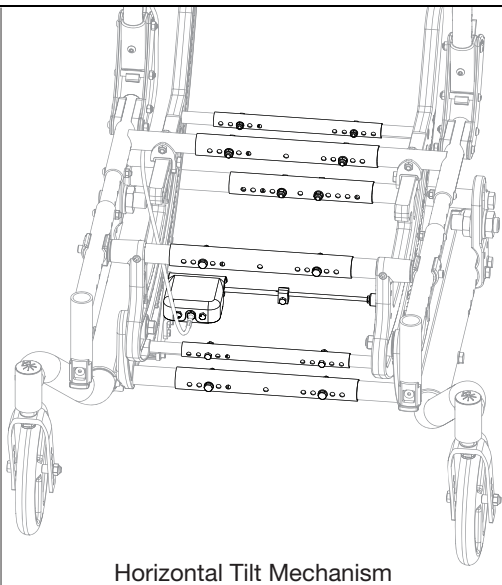

Horizontal Tilt Mechanism

Use the diagram below to determine hole locations needed to achieve a specific width.

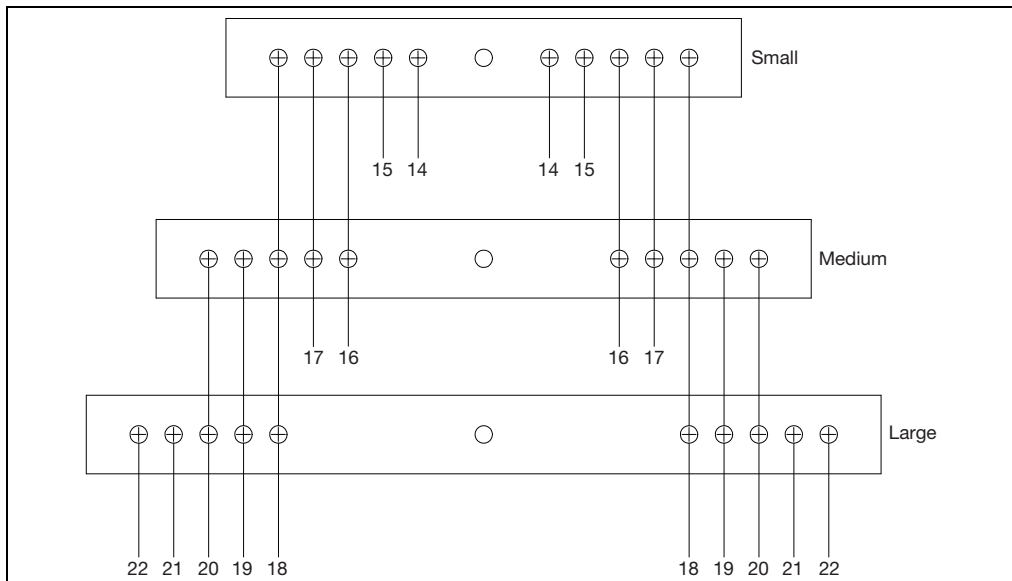

Seat Depth

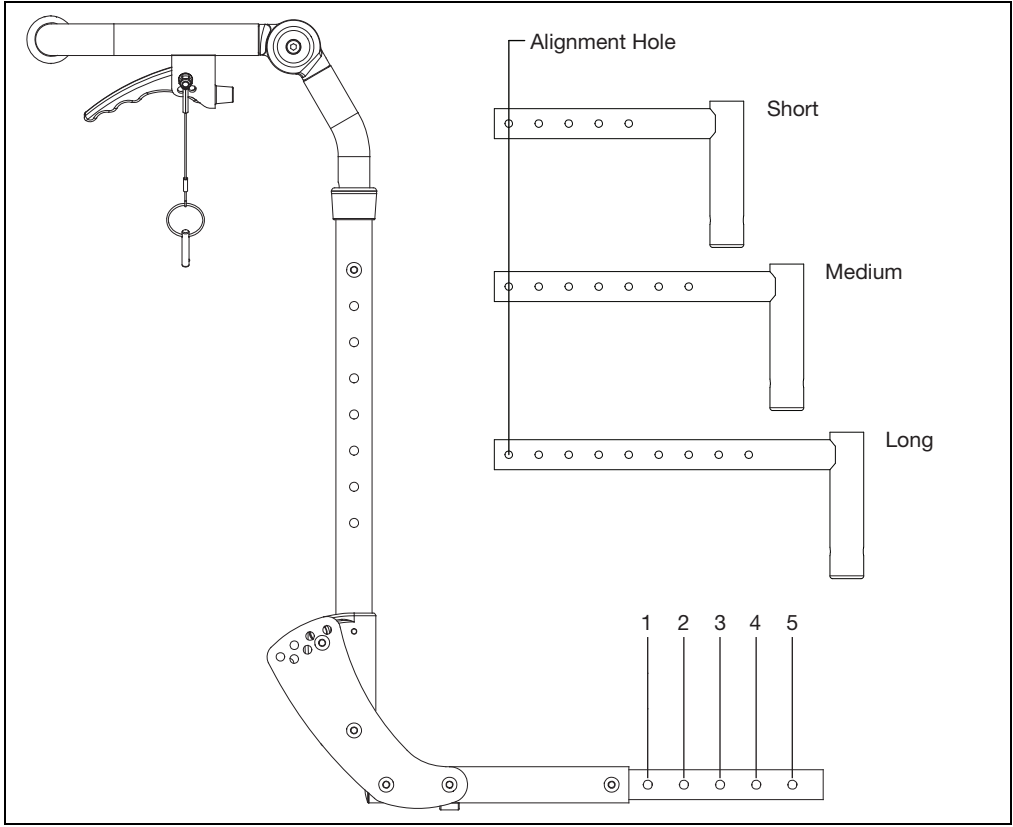

Frame Depth for Frame Size

Hole Number	Short	Medium	Long
1	14	16	18
2	15	17	19
3	16	18	20
4	17	19	21
5	18	20	22

Tilt Mechanism Installation

NOTE: Remove any seating / cushion on the chair along with the seat pan for access in later steps.

Removing Foot Tilt (If applicable) (See Removing Hand Tilt section below for Horizontal Foot Tilt)

1. Use two 13mm wrenches to remove the two bolts (A) and nuts (B) on the foot tilt pedal. Reinstall the axle plate (C) and anti-tip bracket (if applicable) (D) once the pedal is removed. New bolts have been provided for reinstalling the axle plate to prevent excess thread exposure. The longer screws are for chairs with foot lock.
2. Detach drive rod by removing nut (E) using a 2.5mm, 5.5mm or 8mm wrench (depends on version).
3. Remove tilt mechanism assembly by removing two bolts (F) and two washers (G), on each side, with a 10mm wrench.

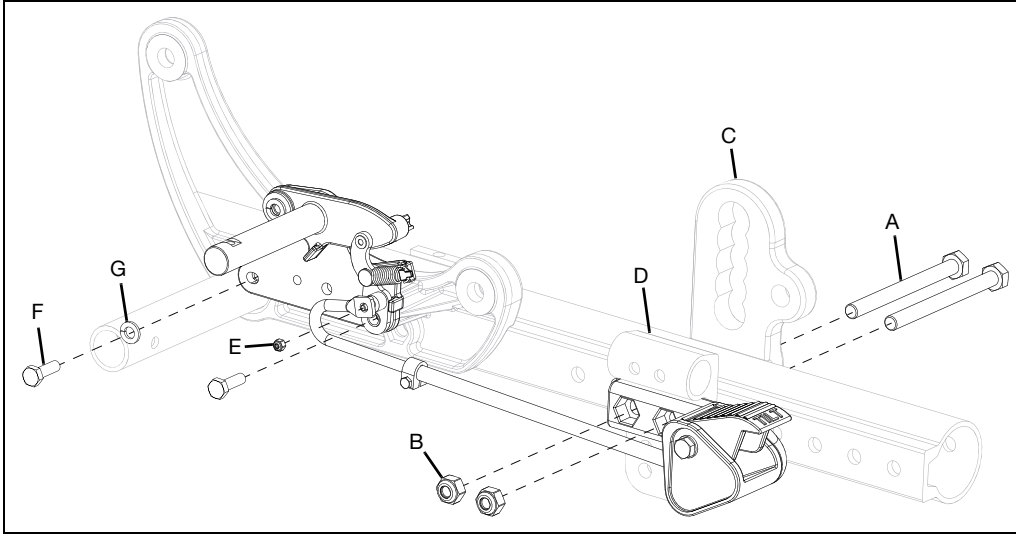

Removing Hand Tilt (If applicable)

1. With a tilt mechanism Revision 1, detach existing cable by removing bolt (A) with 2.5mm Allen wrench. For a tilt mechanism Revision 2, detach existing cable by removing nut (B) and drive bushing (C) located on tilt mechanism with a 5.5mm wrench. For tilt mechanism Revision 3, detach existing cable by removing E-Clip (D). Remove cable from mount (E). For horizontal tilt, remove two cover bolts (A) with 8mm wrench to remove cover (F). Engage the cam lever (G) and drive cam lever (H) so the cable slots align. Remove cable upward. See image in Horizontal Hand Tilt section on page 34 for reference if needed. For a horizontal foot tilt, the foot drive rod is detached by removing the upper E-Clip. See image in Horizontal Foot Tilt section on page 36 for reference if needed.

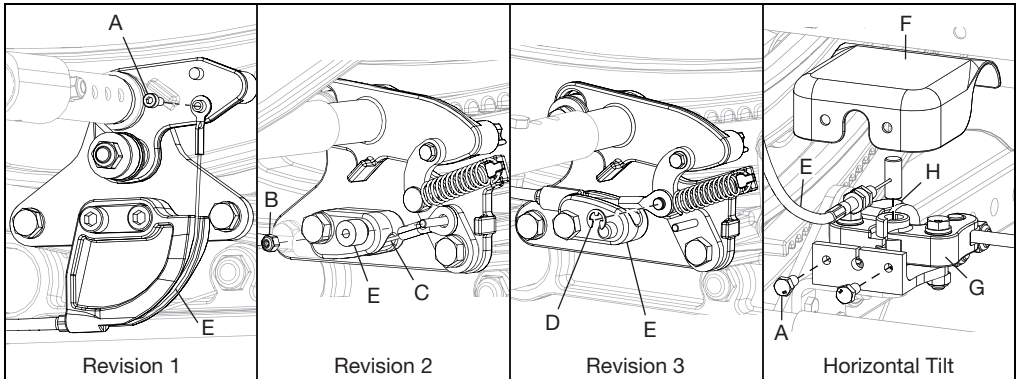

Tilt Mechanism Installation

- Use a 10mm wrench and a 4mm Allen wrench to remove P-Clip (A) securing cable, located by backrest mounting plate, by removing the nut (B) while keeping bolt in place. Once P-Clip is removed, reinstall nut.

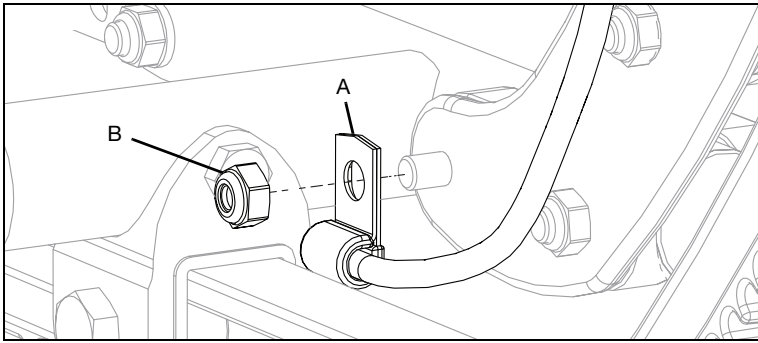

- Remove cable clip(s) (A) on the back cane and finish cable removal by pulling cable out of the tilt lever (B).

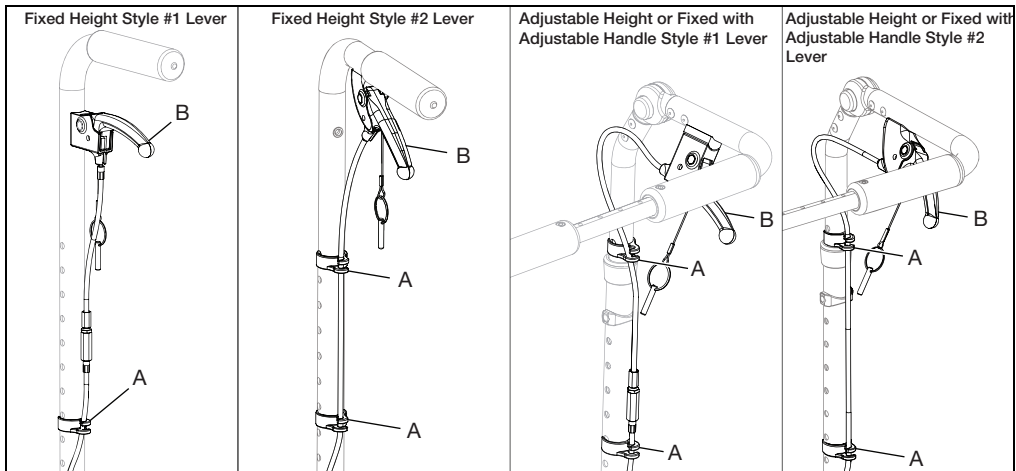

- Remove tilt lever by lifting lever to access lever mounting screw. Remove lever by using a #2 Phillips screwdriver.
- Remove tilt mechanism assembly by removing two bolts (A) and two washers, on each side, with a 10mm wrench. Repeat on opposite side. Remove horizontal foot tilt by removing two bolts and two nuts using a 13mm wrench. See image in Horizontal Foot Tilt section on page 36 for reference if needed.

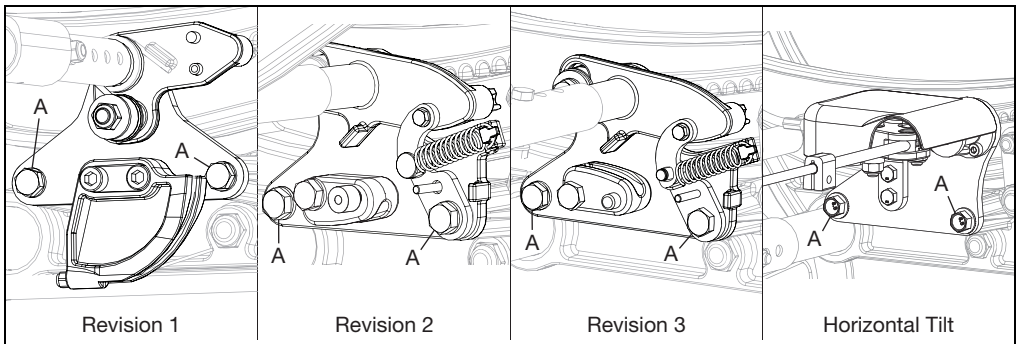

- For a dual hand tilt, repeat the same steps on the opposite side.

Tilt Mechanism Installation

Removing Power Tilt

NOTE: Remove any seating / cushion on the chair along with the seat pan for access in later steps.

NOTE: Unplug all cables from the battery before doing any work.

NOTE: The first six figures below show a Revision 2 power Tilt. The steps for removal are the same for Revision 1 and 2 power tilts unless otherwise noted.

1. Remove power tilt rack assembly by removing four bolts (A), four washers (B) and four nuts (C) using two 10mm wrenches. Guide the front end of the power tilt rack assembly out of the gearbox to remove. Retain all hardware.

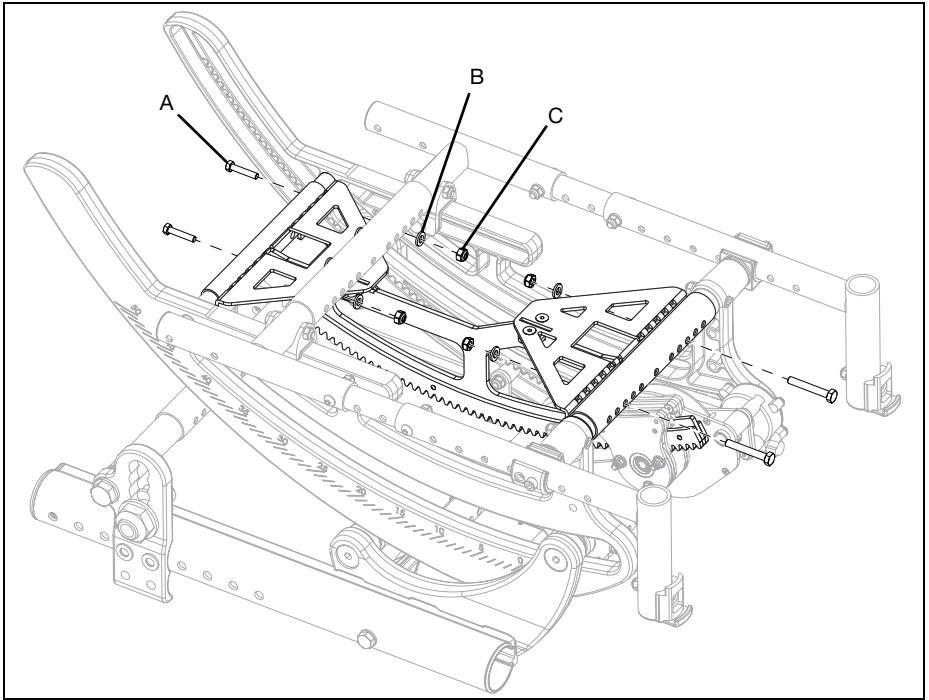

2. Remove battery bracket (A) by removing two bolts (B) using an 8mm wrench. With bracket removed, remove battery (C). Retain all hardware.

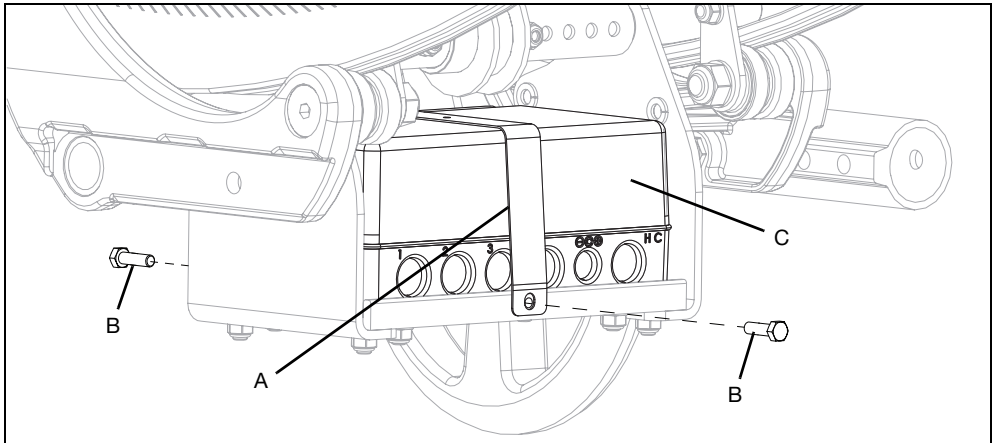

Tilt Mechanism Installation

3. Remove two bolts (A), four washers (B) and two nuts (C) on the power tilt strut tubes using two 10mm wrenches. Retain all hardware.

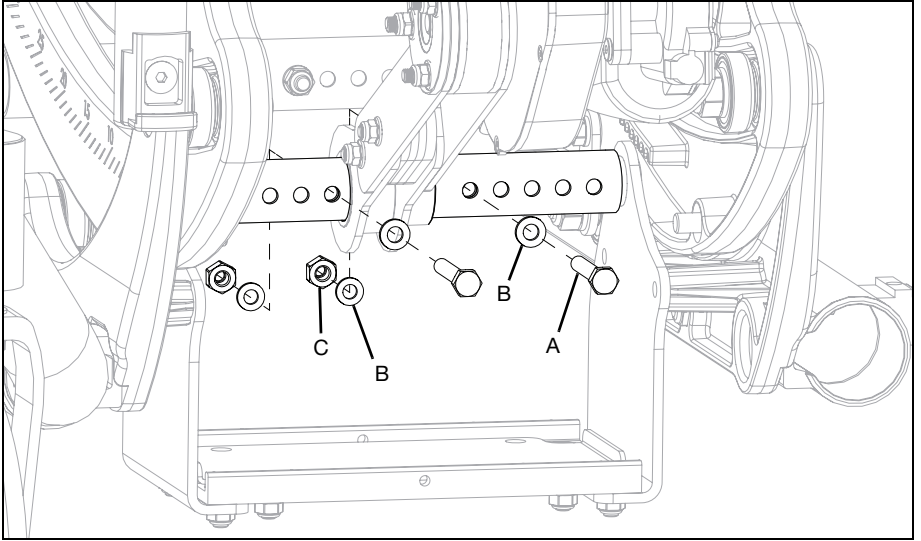

4. Remove battery tray / motor assembly from chair by removing four bolts (A) and four lock washers (B) using a 10mm wrench. Remove end of motor arm (C) from power tilt strut tube (D).

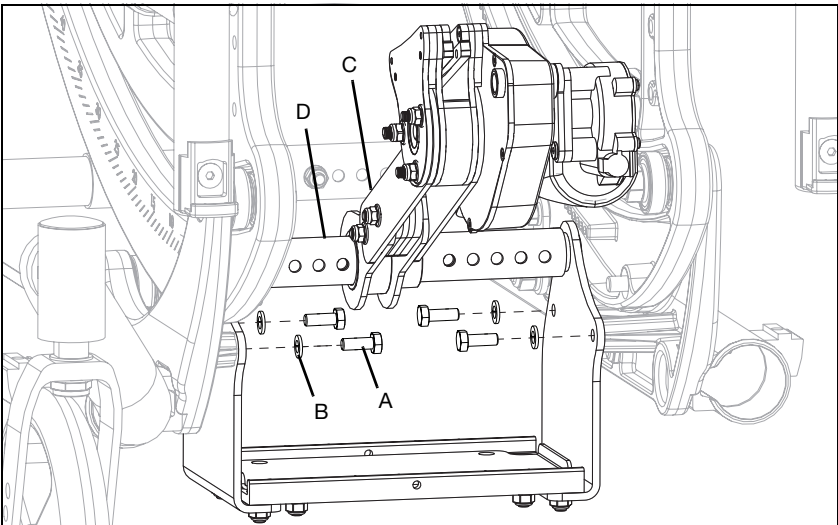

Tilt Mechanism Installation

5. Detach hand control toggle switch (A) by removing bolt (B) and lock washer (C) using a 10mm wrench.

NOTE: Some power tilt chairs will use a pendant control instead of the hand control toggle switch. A pendant control is not installed with hardware, it has a bracket that allows it to hang from different points on the chair.

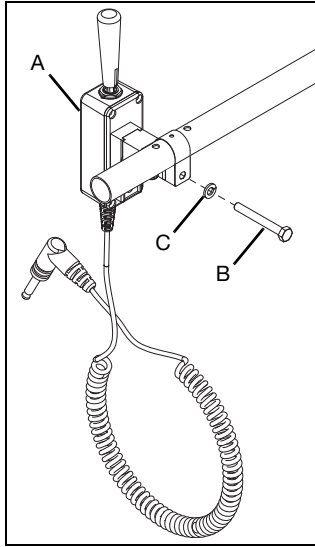

6. For Revision 2 Power Tilt Only - Remove extension cable mount (A) by removing bolt (B), two washers (C) and nut (D) using two 13mm wrenches.

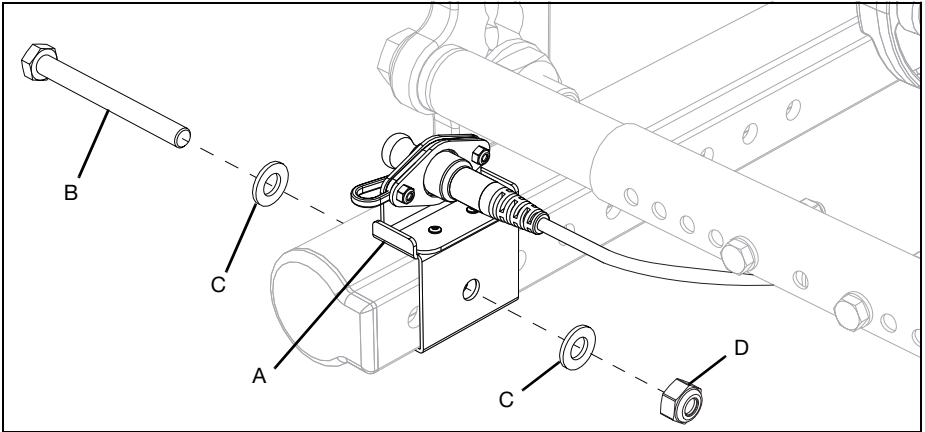

Tilt Mechanism Installation

Installing Horizontal Single Hand Tilt Mechanism

1. Install horizontal hand tilt mechanism assembly onto chair with four bolts (A) using a 10mm wrench. Ensure the cog (B) is installed inside the rotary frame track. For a heavy duty, two spacers go between the frame and tilt mechanism.

NOTE: Hold tilt mechanism assembly up as high as possible for the best cog engagement with the rotary frame teeth while tightening the bolts.

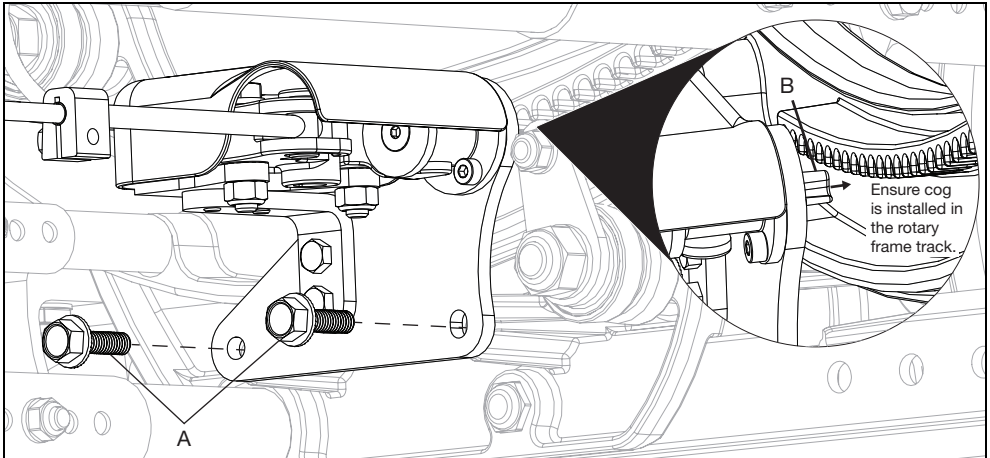

2. Slide the tilt lock tube (A) toward opposite side of chair until it stops without disengaging the cog from the opposite side. Tighten the clamp (B) so the face of the clamp is flush with the end of the tube using an 8mm wrench.

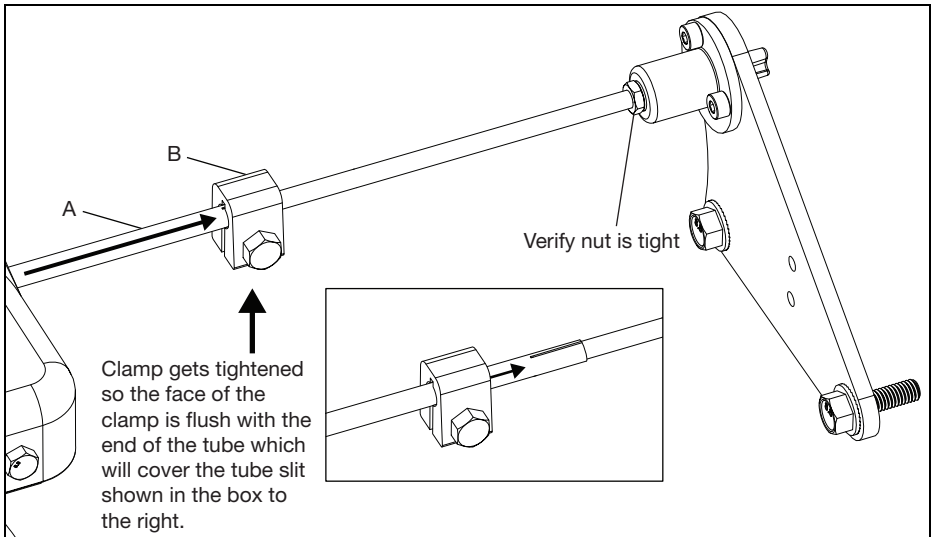

Tilt Mechanism Installation

3. Install tilt lever (A) with mounting screw (B) using a #2 Phillips screwdriver. Install cable into tilt lever.

NOTE: Adjustable height chairs with Style #1 levers will have a spacer (C) installed with the tilt lever.

NOTE: If you are installing the tilt mechanism on a reclining back chair, the location of the lever will be the same as a fixed height. The steps and hardware will also be the same as a fixed height. See image below.

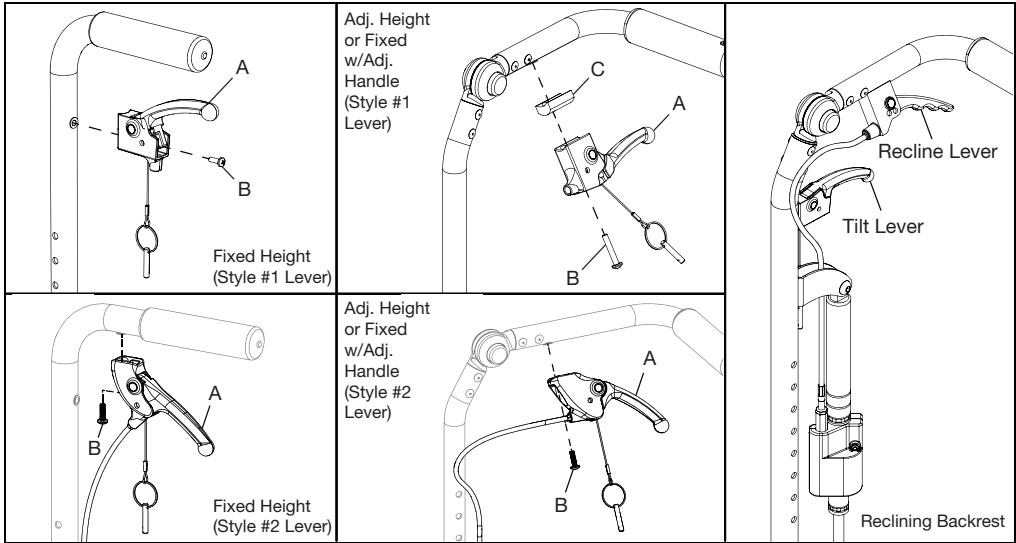

4. Route cable down along back cane and secure with cable clips.

NOTE: A horizontal single tilt chair will not have the cable adjuster on the cable by the lever.

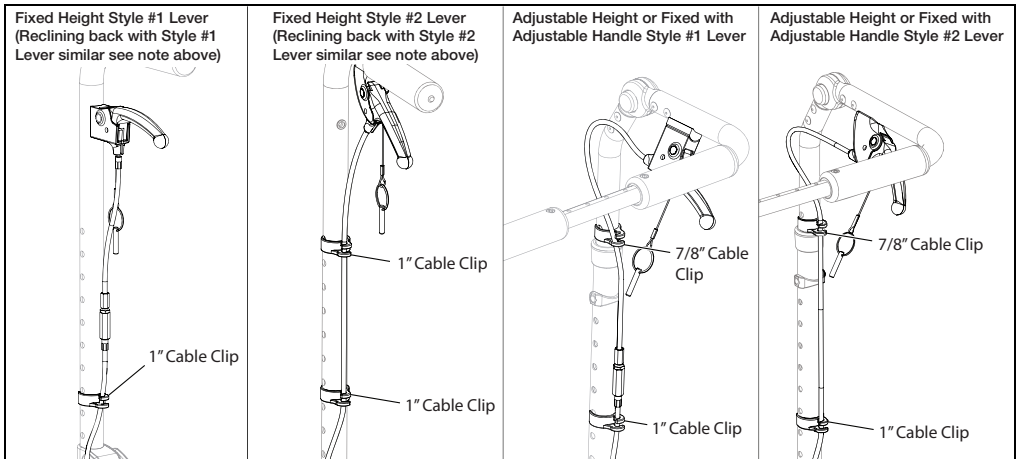

Tilt Mechanism Installation

5. Route cable down to back plate, along the seat frame and over the rotary frame. Secure cable to back plate using P-Clip (A) and existing nut (B) with a 10mm wrench and a 4mm Allen wrench. Ensure cable has enough slack to move through the range of tilt.

NOTE: The new tilt mechanism cable routing goes along the seat frame and through the side of the rotary frame, unlike previous versions which went all the way around the front of the rotary frame. New tilt mechanism cables will not work properly if routed incorrectly.

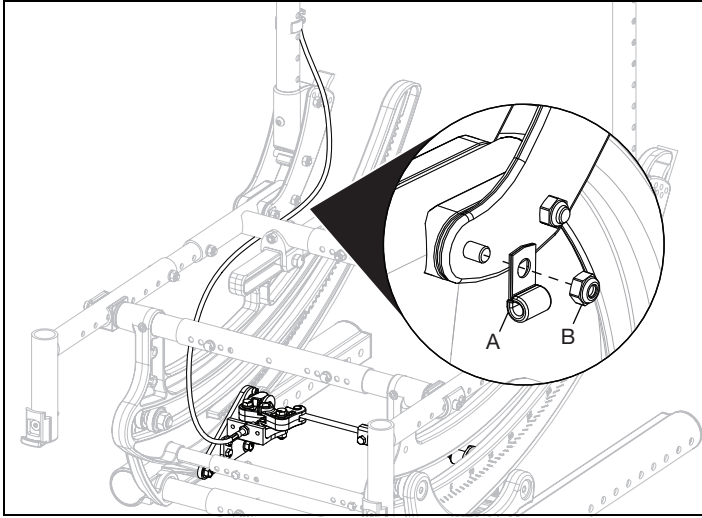

6. Install cable adjuster (A) into the hole in the bracket by lowering through the slot if not preinstalled. Ensure there is a jam nut (B & C) on each side of bracket. Squeeze the cam levers together so the slots in the cam levers align and insert the cable barrel (D) into the cam lever opening (E) if not preinstalled. Tighten cable with adjuster nut (A) counterclockwise. Stop when the trigger has approximately 1/8" of free play before pulling the cable. Tighten jam nut (C) clockwise until B & C are snug on the sides of the bracket. Verify tilt levers fully disengage cogs when squeezed and also that they lock the tilt position when released. Readjust cable if needed.

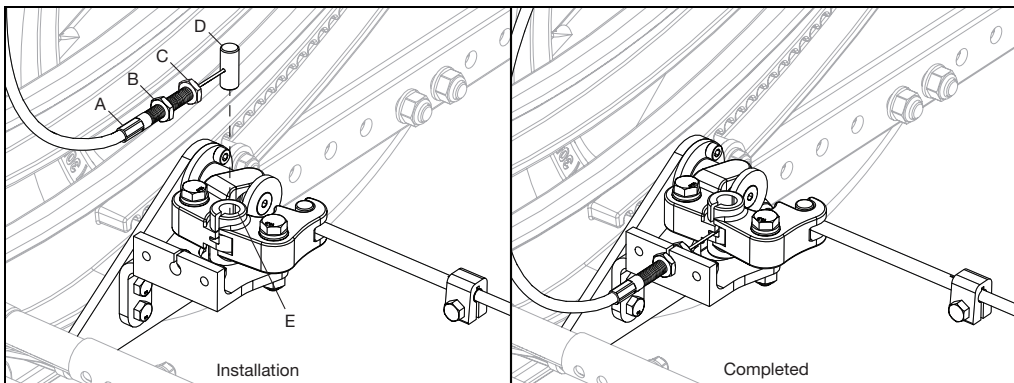

Tilt Mechanism Installation

7. Install cover (A) with two bolts (B) and an 8mm wrench.

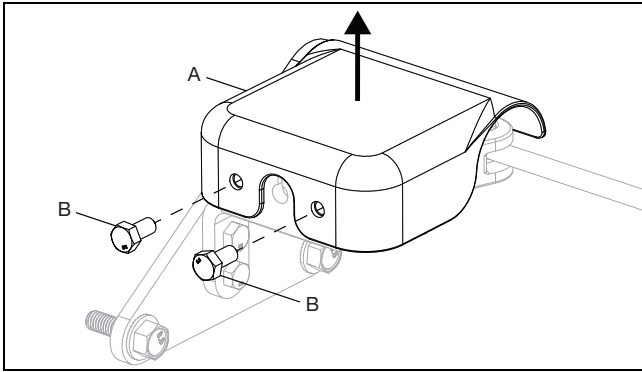

8. Test the tilt mechanism and ensure there isn't excessive play in the lever and also that the cogs remain fully engaged in the rotary frame teeth when the lever is released (chair locks into place).

Horizontal Dual Hand Tilt Mechanism

1. Install dual tilt mechanism assembly onto chair with two bolts (A) using a 10mm wrench. Ensure cog is installed in the rotary frame track. For a heavy duty, two spacers are installed between the frame and the tilt mechanism.

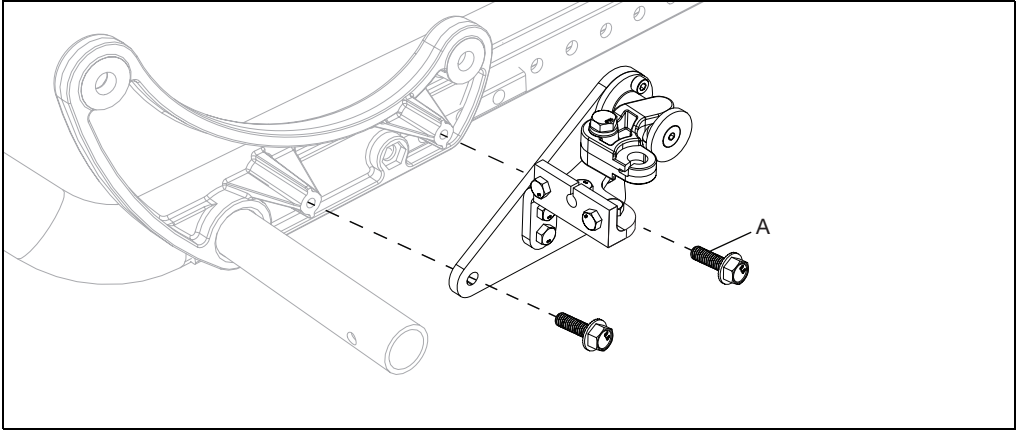

2. The second tilt mechanism is installed on the left side so it mirrors the right.
3. The cable installation and adjustment procedures are the same as a single except that a dual tilt does not have a tilt lock tube. Also, the tilt mechanism on the left side is installed upside down (mirrored from the right side), so the cable is installed from below the cam lever.

Tilt Mechanism Installation

Horizontal Foot Tilt Mechanism

1. Reference the horizontal single hand tilt mechanism installation steps found earlier in these instructions and stop before the cable installation.
2. Install the foot pedal assembly onto the chair frame with spacer (B), two bolts (A) and two nuts (C) using a 13mm wrench.

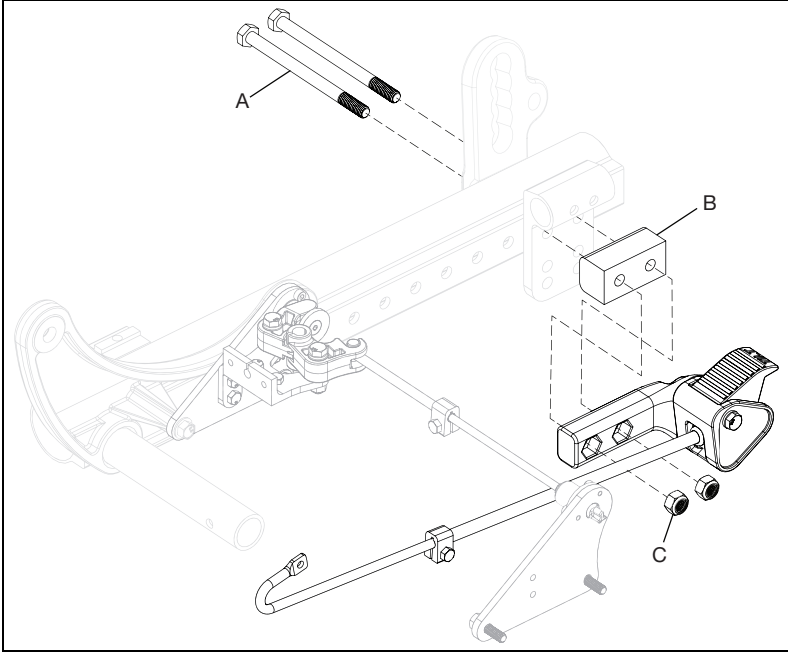

3. Connect the linkage arm to the tilt mechanism with the linkage pin (B), clevis pin (C) and two E-Clips (A).

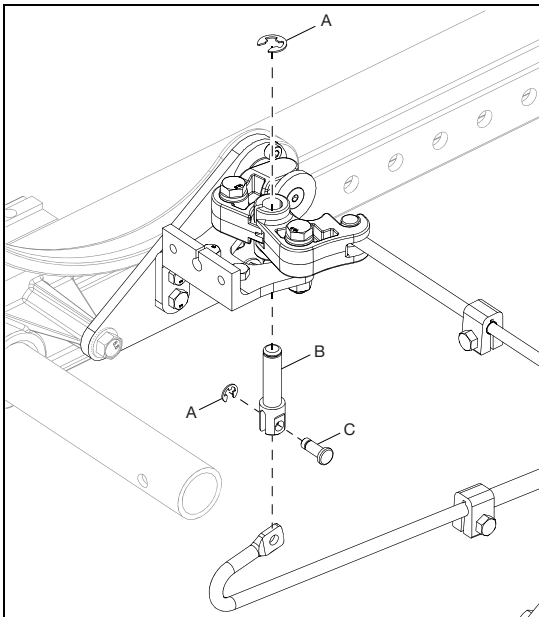

Tilt Mechanism Installation

Adjusting Shaft Clamp

1. To adjust shaft clamp (C), loosen hex bolt (B) on the shaft clamp with an 8mm wrench.
2. Slide the shaft clamp up against the drive rod linkage (A) and retighten shaft clamp.

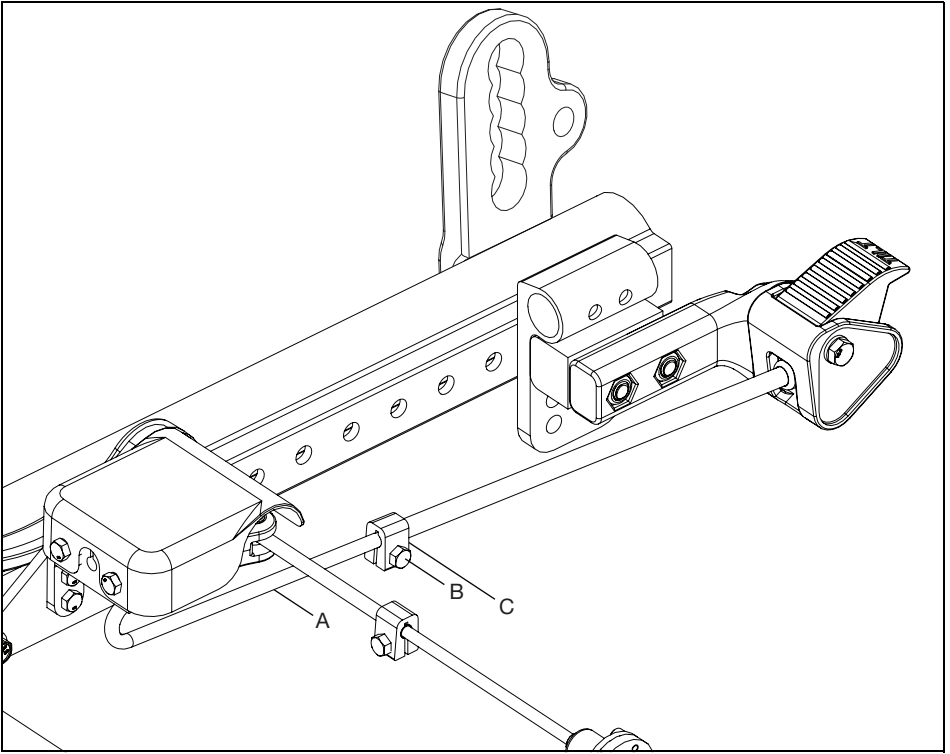

Critical Final Inspection

Place a test person in the chair and confirm that the mechanism operates without friction or binding. Slightly lower the tilt mechanism if friction or binding is noticed.

Rotary Frame Replacement

NOTE: Detaching hangers and armrests will allow more arm room while working through these instructions.

NOTE: Remove battery and vent tray (if applicable) before beginning.

Removing Rotary Frame

1. Remove any seating or cushion components on the chair. Remove the seat pan (B) by removing the four bolts (A), four nuts (E), four seat pan clamps (D) and four seat pan brackets (C) using a 5mm Allen wrench.

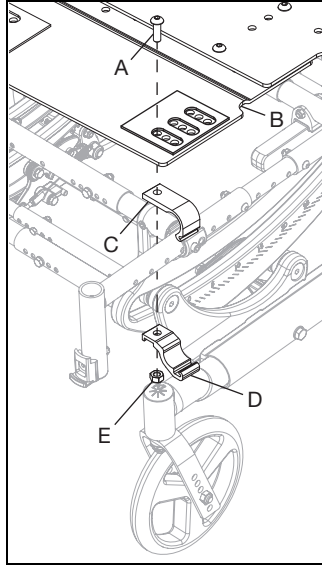

2. Detach tilt cable. For hand tilt, depending on the model, remove the bolt with a 2.5mm Allen wrench (Revision 1), remove nut and bushing with a 5.5mm wrench (Revision 2) or remove the E-Clip (Revision 3). For a horizontal hand tilt, the cable can remain attached to the assembly. For a foot tilt, remove the nut and bushing using a 5.5mm wrench to detach the drive rod (Revision 1). For a Horizontal Foot Tilt, remove the cover by removing the two bolts using an 8mm wrench. Detach rod from tilt mechanism by removing two E-Clips, linkage pin and clevis pin.

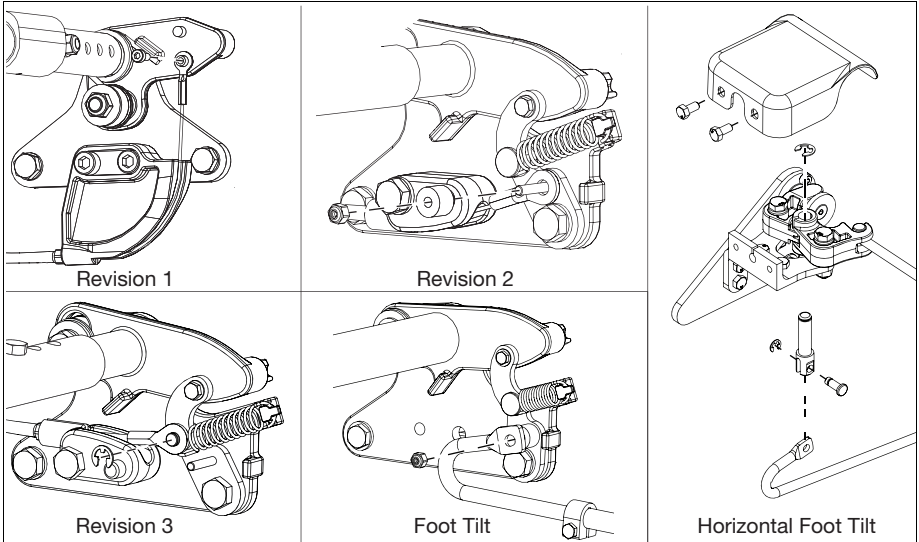

Rotary Frame Replacement

3. Remove the tilt mechanism assembly on your chair by removing four bolts (A) and two lock washers (B) using a 10mm wrench. The horizontal tilt mechanism assembly only uses two bolts on both sides. Heavy duty horizontal tilt will also have two spacers.

NOTE: A horizontal dual hand tilt does not have the tilt lock rod. Two tilt mechanisms, one on each side, are removed.

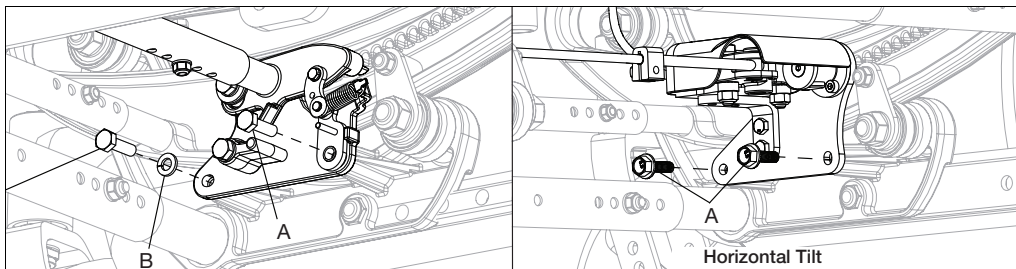

4. Remove the two bolts (A) and two lock washers (B) from the rear seat strut saddles (C) using a 13mm wrench.

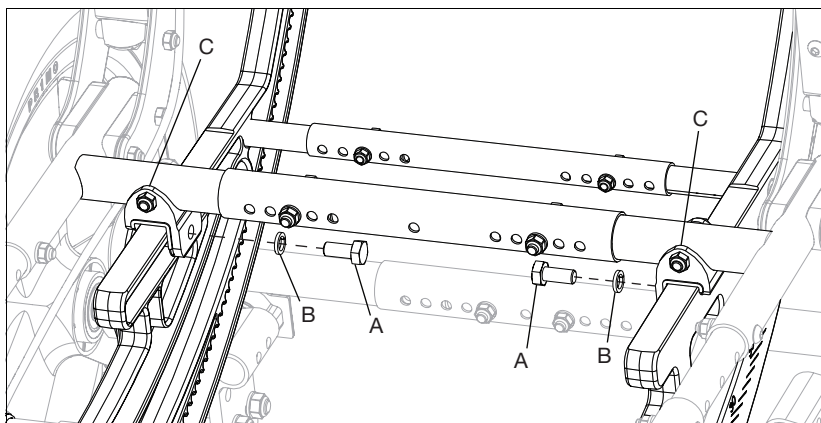

5. Remove four sets of hardware from the front growth strut (A). The inner two bolts (C), two washers (D) and two nuts (E) use two 10mm wrenches for removal. The outer two bolts (F), two washers (D) and two nuts (E) use a 10mm wrench and a 5mm Allen wrench for removal. With hardware removed, remove front growth strut (A) and the two front strut end tubes (B), located inside of the front growth strut.

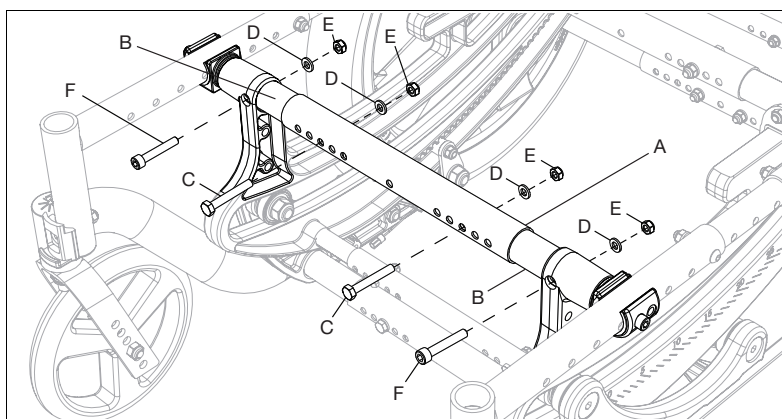

Rotary Frame Replacement

6. Remove two bolts (A), two washers (B) and two nuts (C) from rear growth strut (D) using two 10mm wrenches. Remove rear growth strut and two rear strut end tubes.

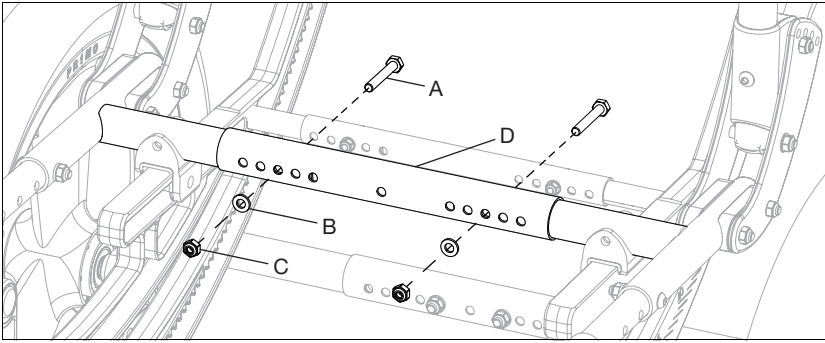

7. For height adjustable and reclining back chairs, remove one screw (A) from the handle with a 4mm Allen wrench.

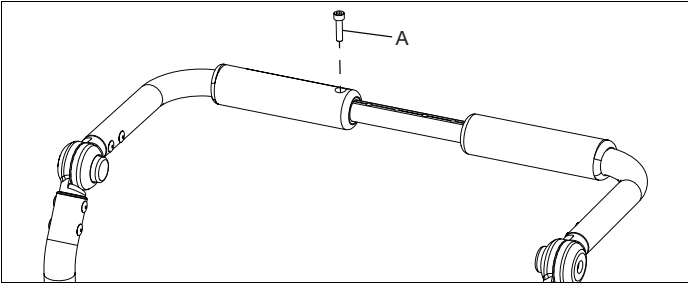

8. Remove chair frame by lifting and tilting frame up and out of the rest of the chair assembly. Set to the side.
NOTE: Be aware of any parts that may drop while transferring chair frame. All parts need to be saved for future steps.

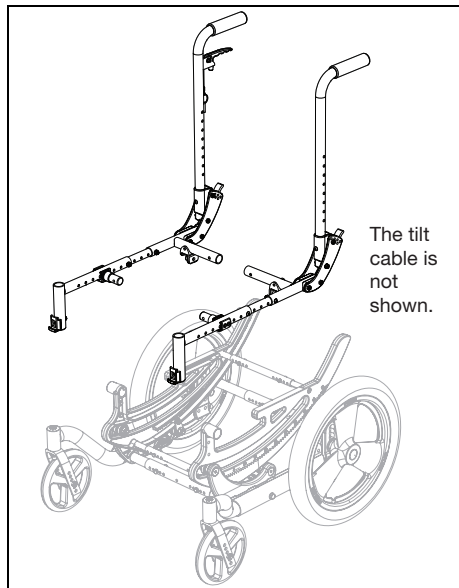

Rotary Frame Replacement

9. Remove the two sets of bearings using a 17mm wrench and a 6mm Allen wrench.

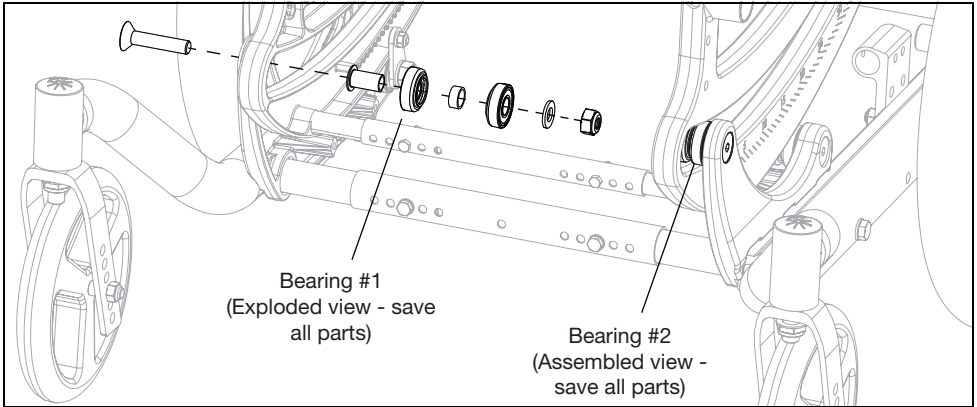

10. Remove the two sets of rear bearing assemblies using a 17mm wrench and a 6mm Allen wrench.

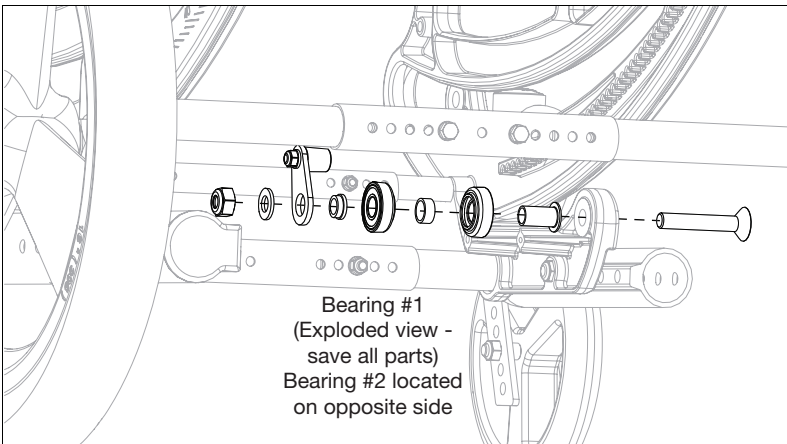

11. Remove the tilt stops (if applicable) and hardware using two 10mm wrenches.

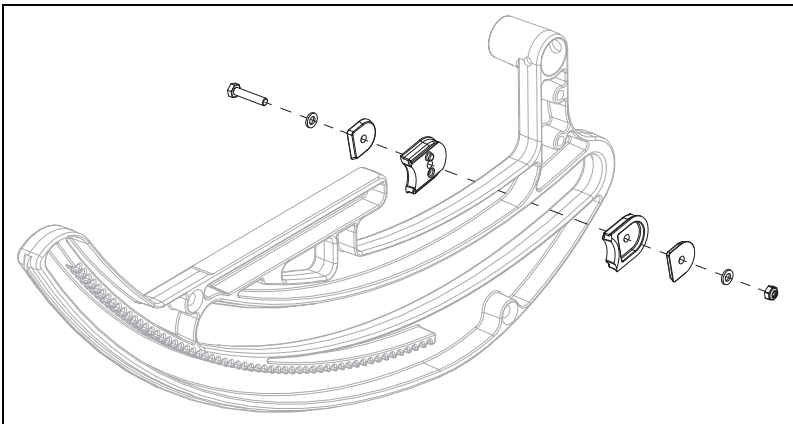

Rotary Frame Replacement

12. If you are replacing the rotary frame assembly skip ahead to Installing Rotary Frame - Step 2. Remove the four strut end bolts (B) using a 6mm Allen wrench. Remove the rotary frames.

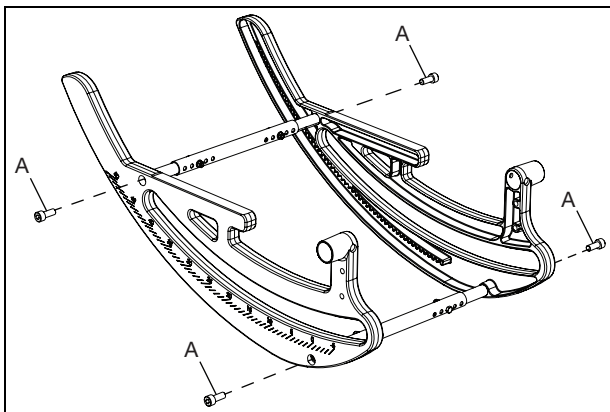

Installing Rotary Frame

1. Reinstall growth struts (A) onto new rotary frames and secure with four strut end bolts (B) using a 6mm Allen wrench.

NOTE: If chair is equipped for transit, ensure new rotary frames have transit brackets and transit decals. If either is missing, please contact Ki Mobility.

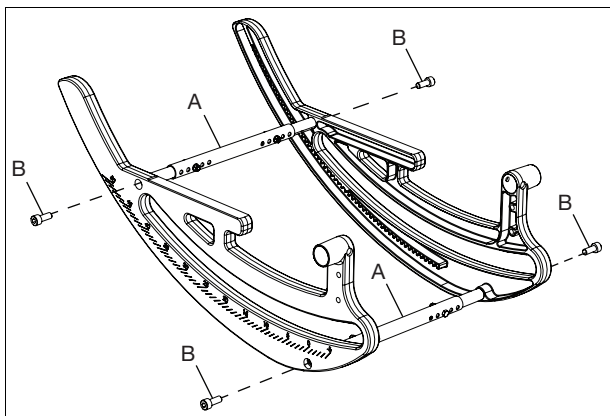

2. Rest the rotary frame assembly in position on the chair and reinstall the two front bearing sets using a 17mm wrench and a 6mm Allen wrench. Leave the hardware loose.

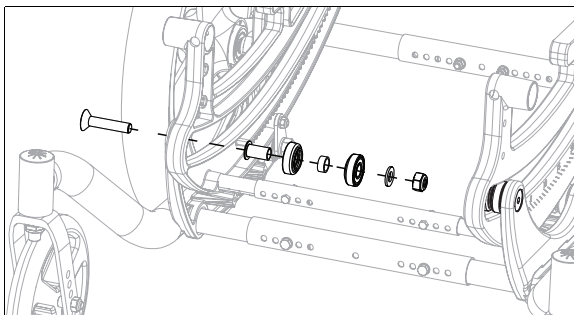

Rotary Frame Replacement

- Reinstall the rear bearing assemblies using an 17mm wrench and a 6mm Allen wrench. Leave hardware loose.

NOTE: The swivel plate arm with the roller bearing needs to be in the rotary frame track before hardware is installed fully.

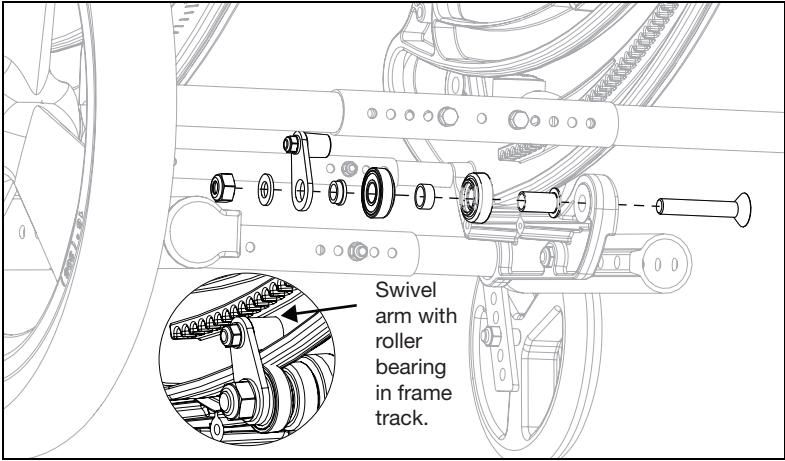

- Ensure that the rotary frames rotate freely. Tighten front and rear bearing assemblies and test the rotation again. If rotary frames stick, loosen assembly hardware so it is more loose, but still snug and secure.
- Reinstall the seat frame assembly to the rest of the chair. Ensure the rear saddle liners (A) are in place when the frame is mounted on the chair. For height adjustable and reclining back chairs, reinstall the screw that was removed in Removing Rotary Frame - Step 7.

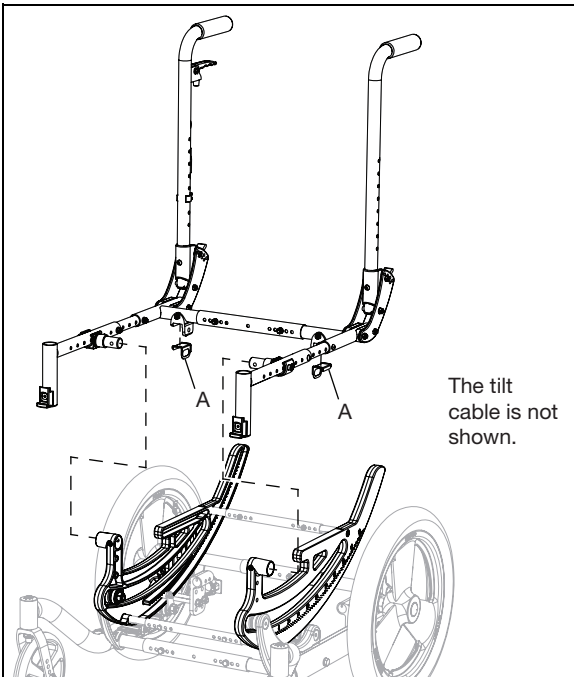

Rotary Frame Replacement

- Secure the rotary frame assembly to the rear saddle by installing bolt (A) and lock washer (B). The bolt and lock washer are secured by the rear seat retainer (C). Repeat on the opposite side.

NOTE: The rear seat retainer (C) has one side that is narrower than the other. The rear seat retainer is installed so the wider side faces the incoming bolt.

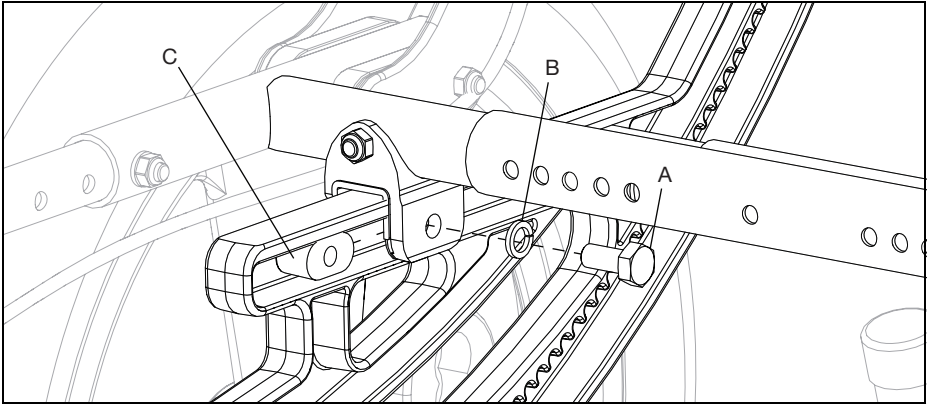

- Reinstall the front growth strut (A) using four sets of hardware. The two front strut end tubes (B) are installed inside the front growth strut. The inner two bolts (C), two lock washers (D) and two nuts (E) use two 10mm wrenches for installation. The outer two bolts (F), two lock washers (D) and two nuts (E) use a 10mm wrench and a 5mm Allen wrench for installation.

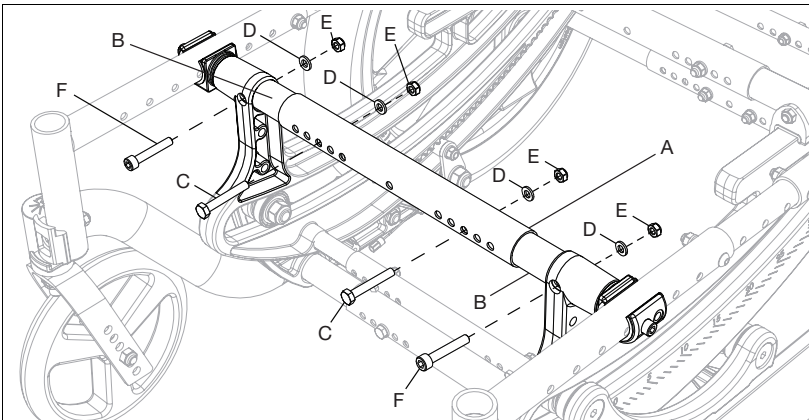

- Slide the two rear strut end tubes (A) inside rear growth strut (B). Install two bolts (C), four washers (D) and two nuts (E) to secure tubes using two 10mm wrenches.

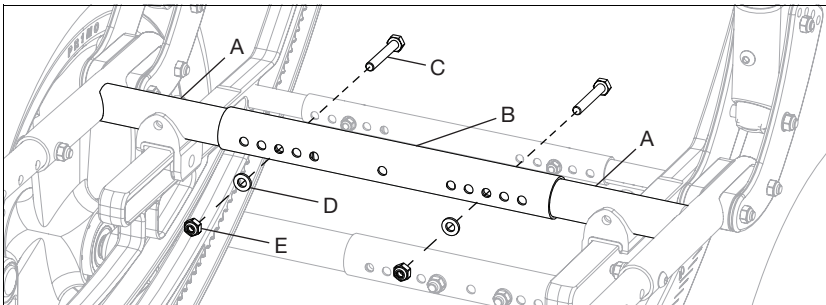

Rotary Frame Replacement

9. Reinstall tilt mechanism onto chair with four bolts (A) and two lock washers (B) using a 10mm wrench. Reattach the cable (hand tilt) or the drive rod (foot tilt) to the tilt mechanism. Refer to Removing Rotary Frame - Step 2 for attached cable views and tools needed. Ensure that the cable(s) go under the rotary frame growth strut (C) and over the base frame growth strut (D). Also, ensure the cable(s) is not pinched, bent or caught in any rotating pieces.

NOTE: The horizontal tilt lock mechanism is installed with two bolts (A) on each side using a 10mm wrench. The heavy duty option has two spacers also installed between the frame and the tilt mechanism. The horizontal dual tilt has two tilt mechanisms that are installed separately. The cable reinstalls through the top on the right side and through the bottom on the left side because the left side mirrors the right. The cable is then routed out the top of the rotary frame and beneath the seat frame to the P-Clip located on the backrest plate.

NOTE: The bolts going into the rear side of the tilt mechanism (bolts without the lock washers) cannot be tightened all the way. Damage will occur to the bushing and the chair may not rotate properly.

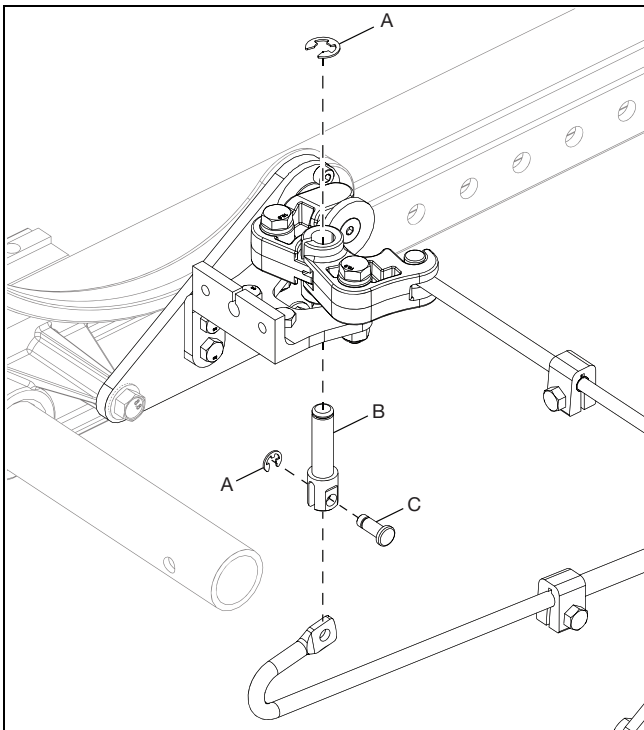
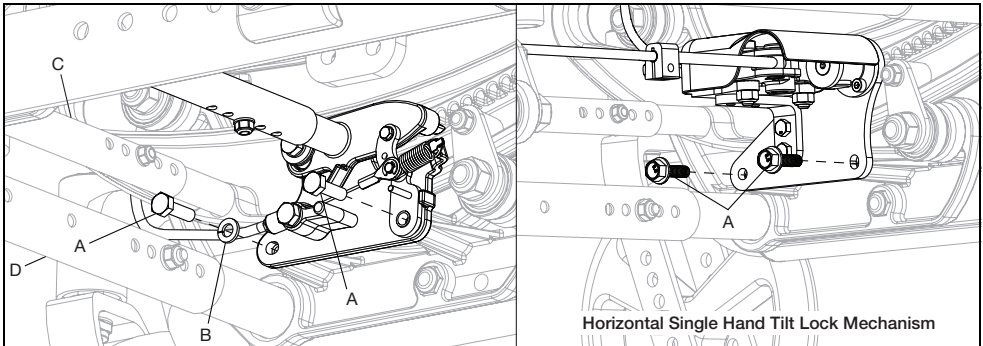

Rotary Frame Replacement

10. For horizontal single hand tilt mechanism - Slide the tilt lock tube (A) toward opposite side of chair until it stops without disengaging the cog from the opposite side. Tighten the clamp (B) so the face of the clamp is flush with the end of the tube using an 8mm wrench.

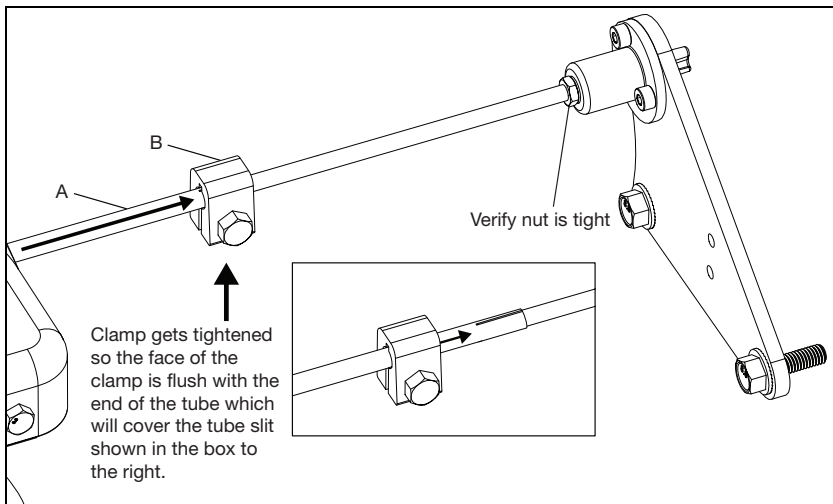

11. Reinstall seat pan (B) by installing four bolts (A), four seat pan brackets (C), four seat pan clamps (D) and four nuts (E) using a 5mm Allen wrench.

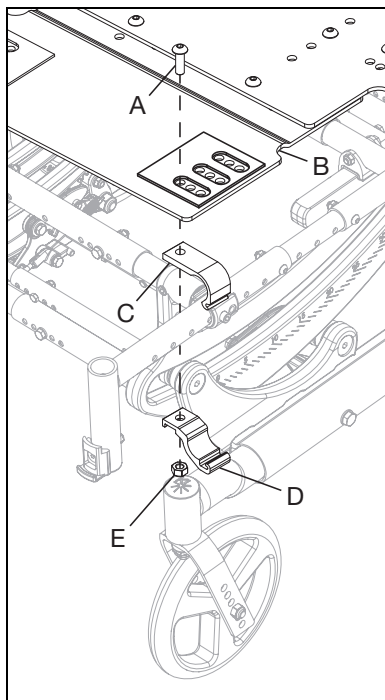

Rotary Frame Replacement

12. Reinstall the tilt stops (if applicable) using two 10mm wrenches.

NOTE: Install tilt stops where necessary for the person using the wheelchair.

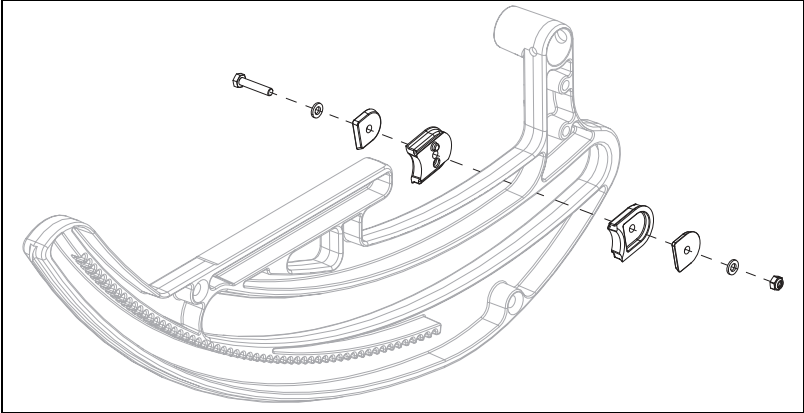

13. Test the wheelchair. Ensure the tilt mechanism cogs properly engage and disengage and the full range of tilt works properly. To adjust a horizontal tilt mechanism, loosen the jam nut (B). Pull the cable adjuster to remove all slack from the cable. While holding cable in this position, thread jam nuts until they are snug on the sides of the bracket. Verify tilt levers fully disengage cogs when squeezed and also that they lock the tilt position when released. Readjust cable if needed.

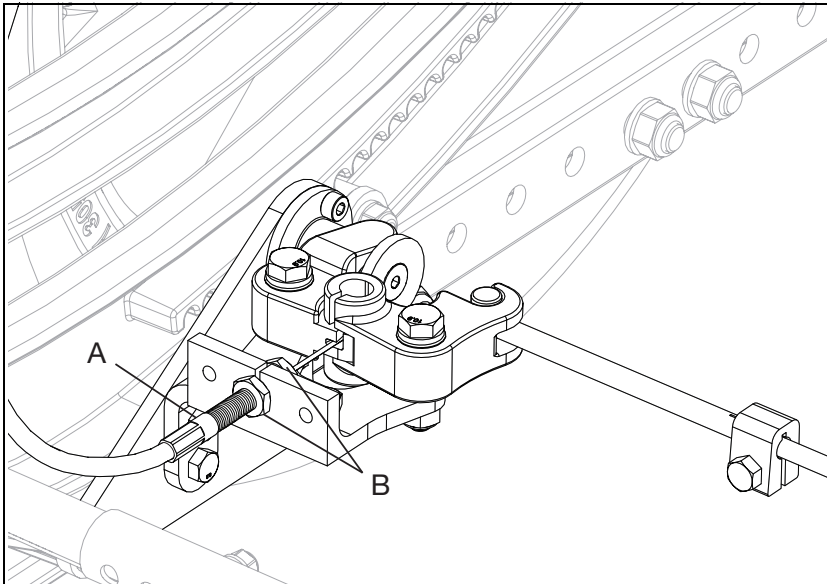

Rotary Frame Replacement

Adjusting Foot Tilt Shaft Clamp

1. To adjust shaft clamp (C), loosen hex bolt (B) on the shaft clamp with an 8mm wrench.
2. Slide the shaft clamp up against the drive rod linkage (A) and retighten shaft clamp.

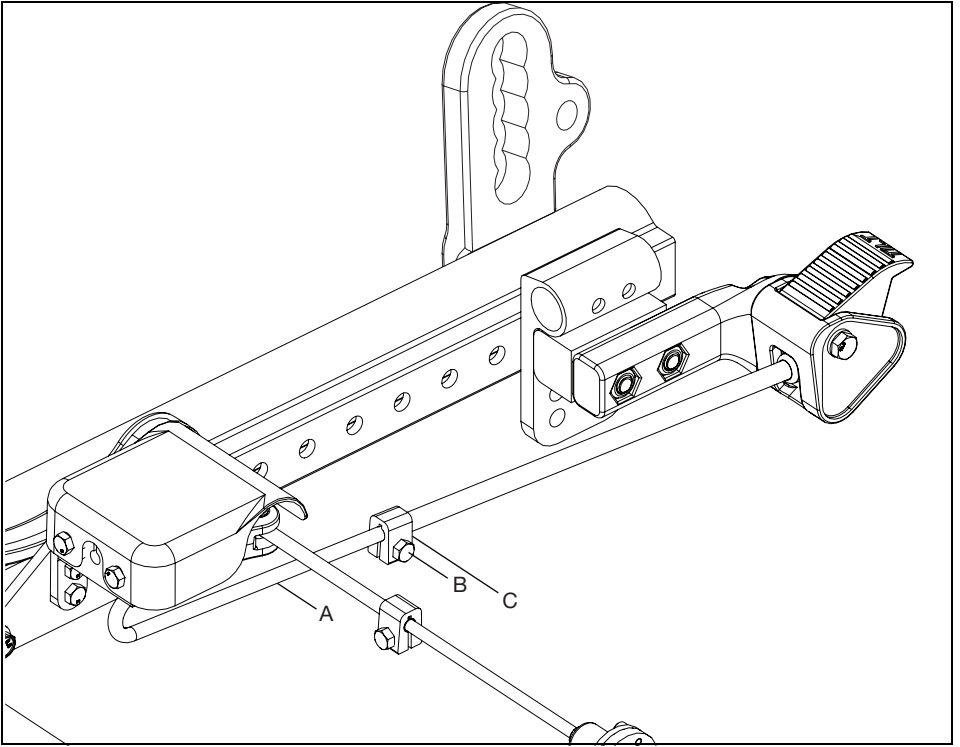

3. Reinstall hangers, armrests, battery vent and tray and any cushion/seating that may have been removed.

Critical Final Inspection

Place a test person in the chair and confirm that the mechanism operates without friction or binding. Slightly lower the tilt mechanism if friction or binding is noticed.

Transit

See the below diagram for transit bracket installation. A 4mm Allen wrench and a 10mm wrench are required for assembly.

NOTE: The WC-19 Transit and Transit Hook decals must be installed in the correct locations shown below.

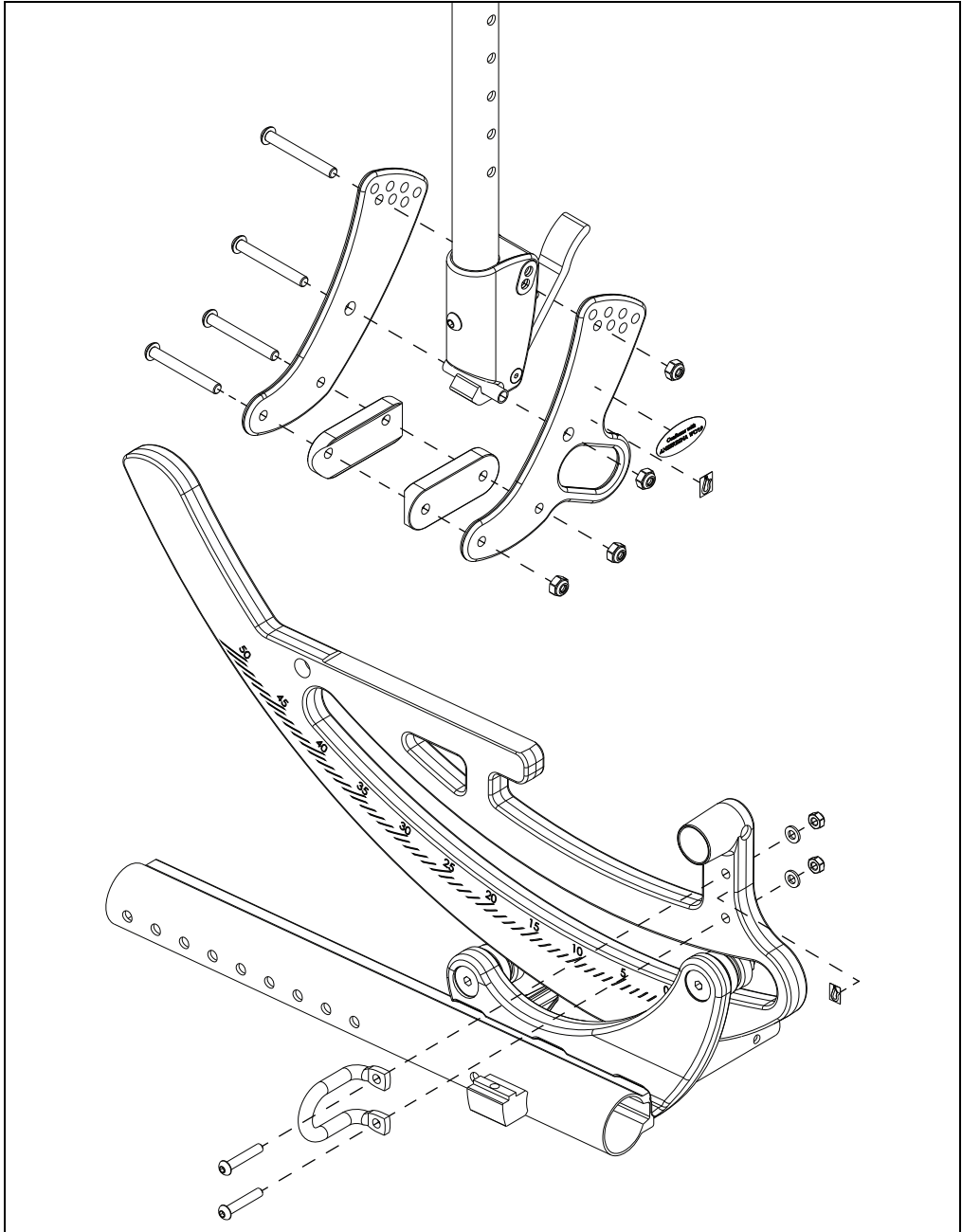

Anti-Tips

1. To adjust height, use a 4mm Allen wrench and a 10mm wrench to remove the cross bolt (A in diagram below) from the height adjuster.
 2. Slide height adjuster up or down and align hole in desired height.
 3. Reinstall cross bolt and repeat on opposite side. Ensure both sides are set in the same configuration.
- See diagrams and charts below for additional anti-tip information.**

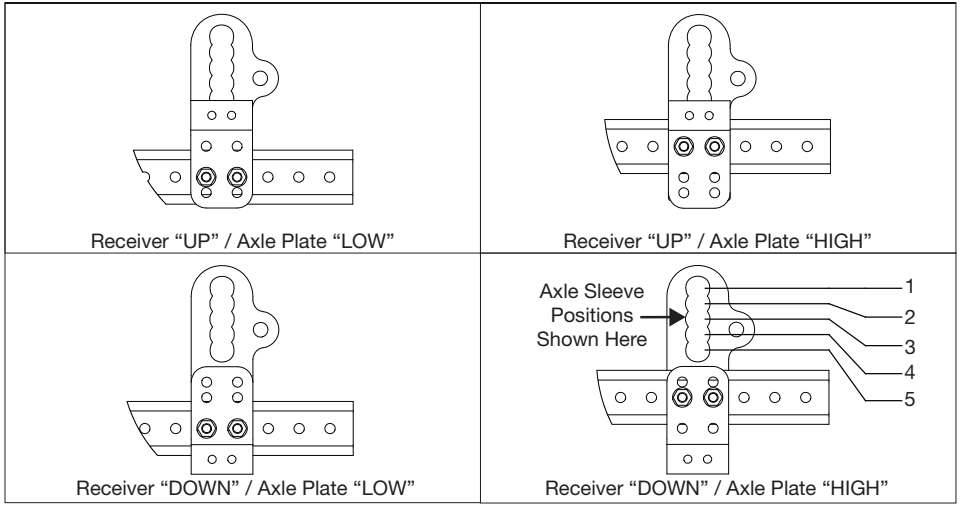
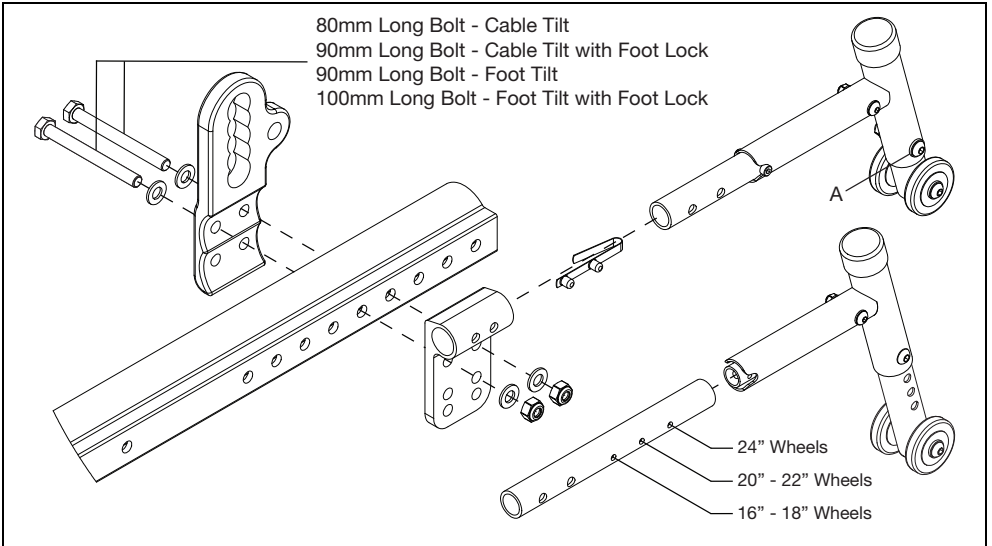

Wheel Size	Axle Sleeve Position	Anti-Tip Receiver Orientation
12	ALL	UP
16	ALL	UP
18	ALL	UP
20	1 - 2	UP
	3 - 5	DOWN
22	ALL	DOWN
24	ALL	DOWN

Back Height

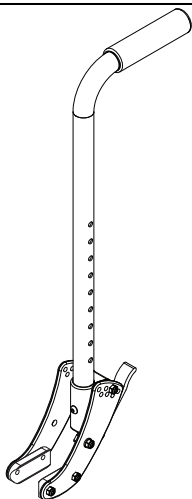

Stroller Handle Backrest - Not Adjustable - Available in Short (20") or Tall (24").

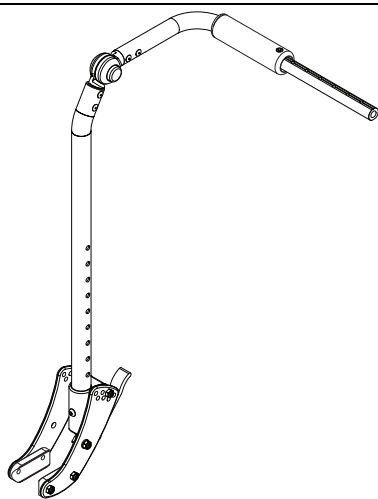

Fixed Height with Adjustable Handle Backrest - Not Adjustable - Available in Short (22") or Tall (26").

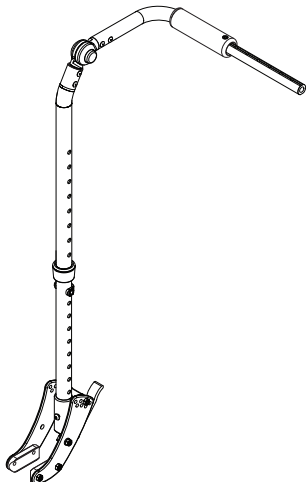

Adjustable Height with Adjustable Handle Backrest - Available in Short (18"-25") and Tall (20"-27").

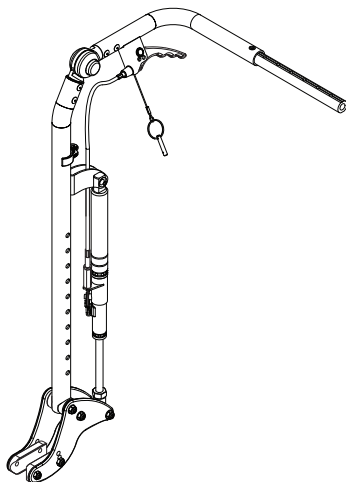

Reclining Back with Adjustable Handle Backrest - Not Adjustable - Available in Short (22") or Tall (26").

To adjust an adjustable height backrest, remove the screw and insert on each backrest tube using an 8mm wrench. Adjust the telescoping backrest tubes to desired height and reinstall hardware through collar.

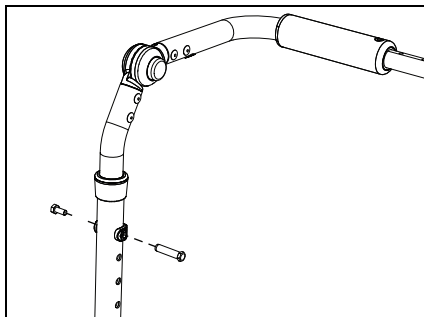

Back Height

Back Post	Height Range	Back Height																
Stroller Handle Back Post	Short	20																
	Tall	24																
Fixed Height with Adjustable Handle	Short	22																
	Tall	26																
Adjustable Height with Adjustable Handle	Short	18									19	20	21	22	23	24	25	
	Tall	20									21	22	23	24	25	26	27	
Reclining Back with Adjustable Handle	Short	22																
	Tall	26																

The Adjustable Height with Adjustable Handle backrest is adjustable using an 8mm wrench. See the diagram below.

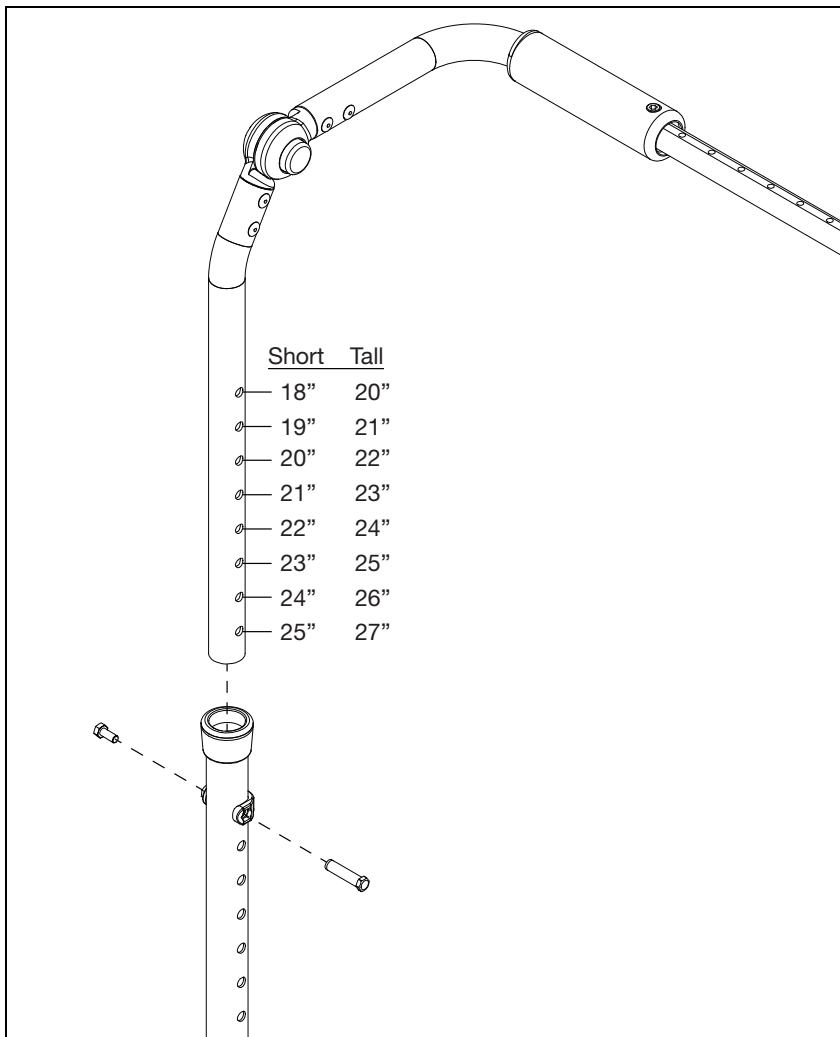

Backrest Angle Adjustment

1. Use a 4mm Allen wrench and a 10mm wrench to remove the button head screw and nut on the backrest.
2. Rotate backrest to desired angle. Each hole represents 5° of rotation. See diagram below for the angle for each hole.
3. Replace screw and nut in desired hole location.
4. Repeat for opposite side. Ensure both sides use the same configuration settings.

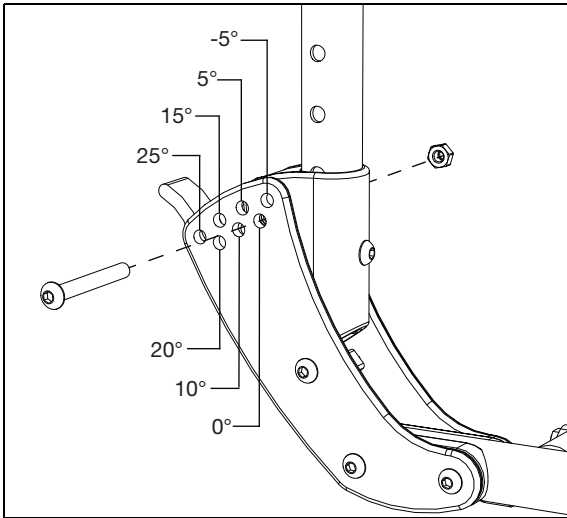

Reclining Backrest

NOTE: The patient **MUST** be removed from wheelchair prior to making an adjustment on the reclining backrest.

1. The reclining option comes with three different backrest angle adjustment options. See the diagram below for range information prior to making the adjustment.
2. Using a 4mm Allen wrench and a 10mm wrench, remove button head screw, washer and nut.
3. Rotate backrest to desired angle. Each hole represents 65° of rotation.
4. Replace button head screw, washer and nut and tighten until securely fastened.
5. Repeat for opposite side of chair. Both sides should be set up in the same configurations.

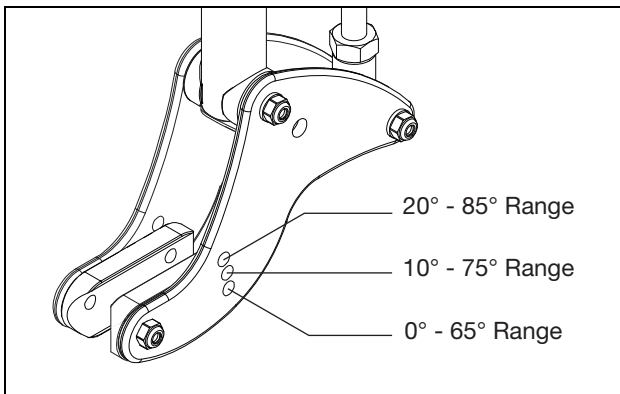

Seat Pan

Seat Pan Size	Frame Depth	Front Seat Pan Mounting Holes	Rear Seat Pan Mounting Holes	Dimension A
Short	14	1 & 5	1 & 5	15.0"
	15	2 & 5	1 & 4	16.0"
	16	3 & 5	1 & 3	17.0"
	17	4 & 5	1 & 2	18.0"
	18	4 & 5	1 & 2	18.0"
Medium	16	1 & 5	1 & 5	17.0"
	17	2 & 5	1 & 4	18.0"
	18	3 & 5	1 & 3	19.0"
	19	4 & 5	1 & 2	20.0"
	20	4 & 5	1 & 2	20.0"
Long	18	1 & 5	1 & 5	19.0"
	19	2 & 5	1 & 4	20.0"
	20	3 & 5	1 & 3	21.0"
	21	4 & 5	1 & 2	22.0"
	22	4 & 5	1 & 2	22.0"

After referencing the chart above, see the assembly diagram below. Two 13mm wrenches are needed when attaching the clamps with the bolt and nut.

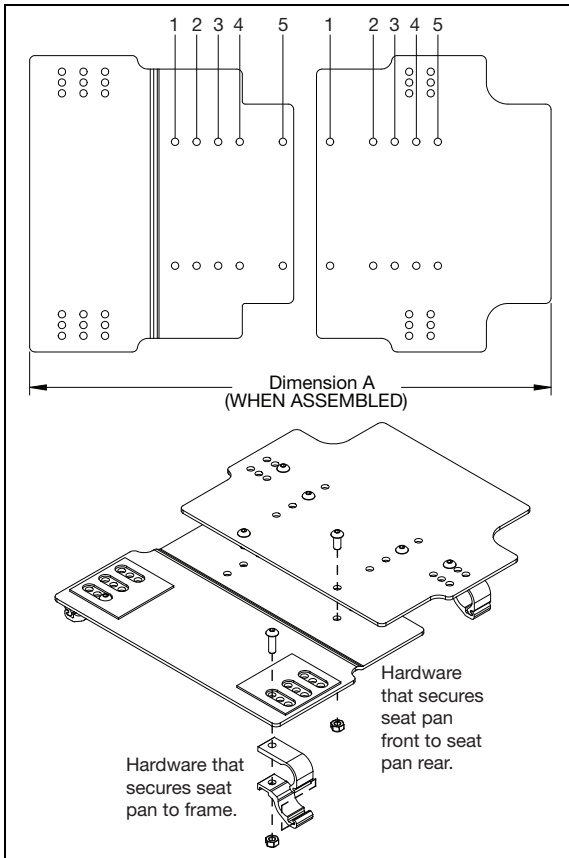

Center of Gravity (COG)

COG Fully Rearward

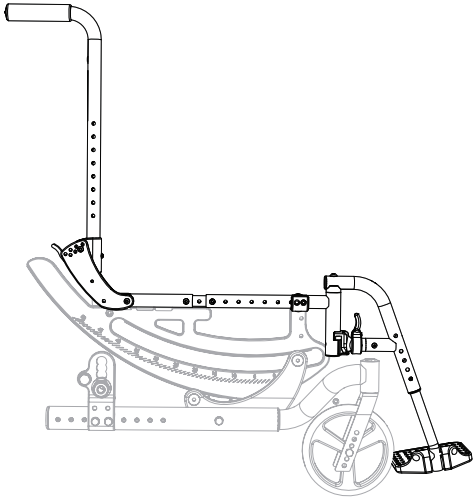

COG Fully Forward

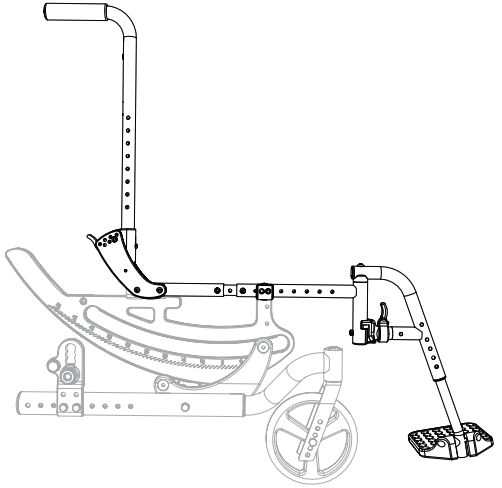

Check your current COG by engaging pins in levers and letting the chair (with user seated) settle into its natural resting point. Read the degree on the rotary frame (shown below). 20° is the desired resting angle position.

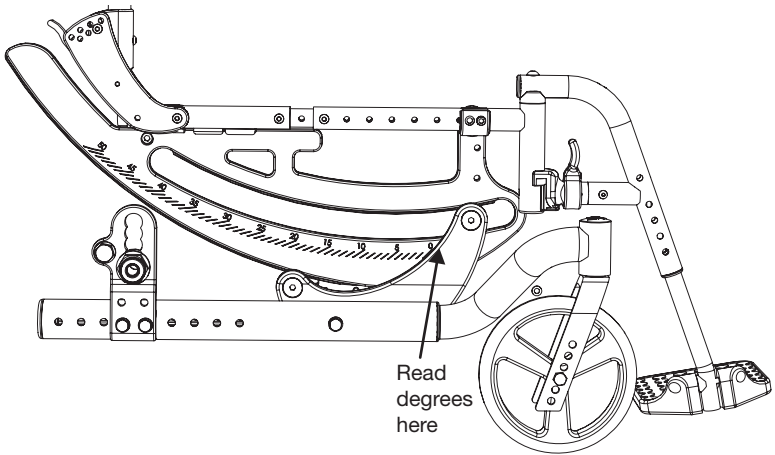

Center of Gravity (COG)

If the chair COG needs adjusting use the diagrams and chart below to correct.

System Resting Position	Adjustment Required
System Rests Between 50 and 45	3 Holes Forward
System Rests Between 44 and 35	2 Holes Forward
System Rests Between 34 and 25	1 Hole Forward
System Rests Between 24 and 16	Acceptable
System Rests Between 15 and 7	1 Hole Rearward
System Rests Between 6 and -2	2 Holes Rearward
System Rests Between -3 and -5	3 Holes Rearward

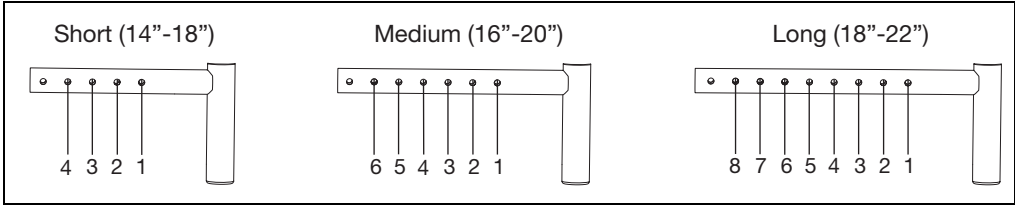

CG Position to Caster Arm Position	
Seat Frame Position	Caster Position
F1	1
F2	1
R2	1
F3	1
R3	1
F4	2
R4	2
F5	3
R5	3
F6	4
R6	4
F7	4
R7	4
R8	4

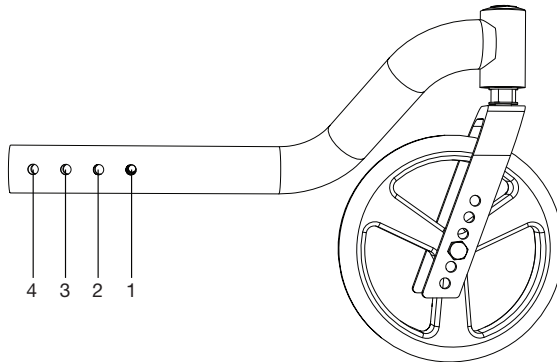
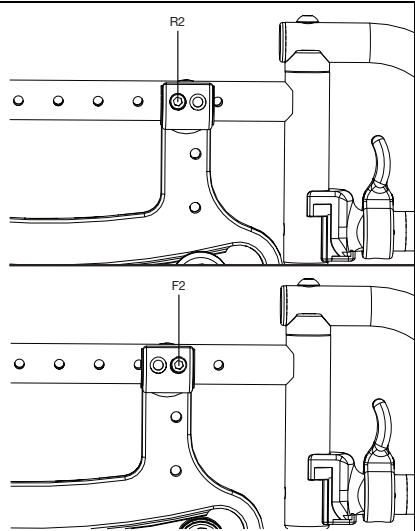

Caster Arm

1. Slide caster arm assembly into base frame tube and secure with bolt, washer and nut using a 13mm wrench. The nut fits into a recess on the inside of the base frame tube.

NOTE: There are different holes on the caster arm that can be used for installation. Ensure both caster arms are installed using the same mounting holes and that the front seat tube does not extend beyond the casters in the front. If you do not know which hole to use, see your Owner's Manual for caster arm adjustments or view our Tech Guide on our website.

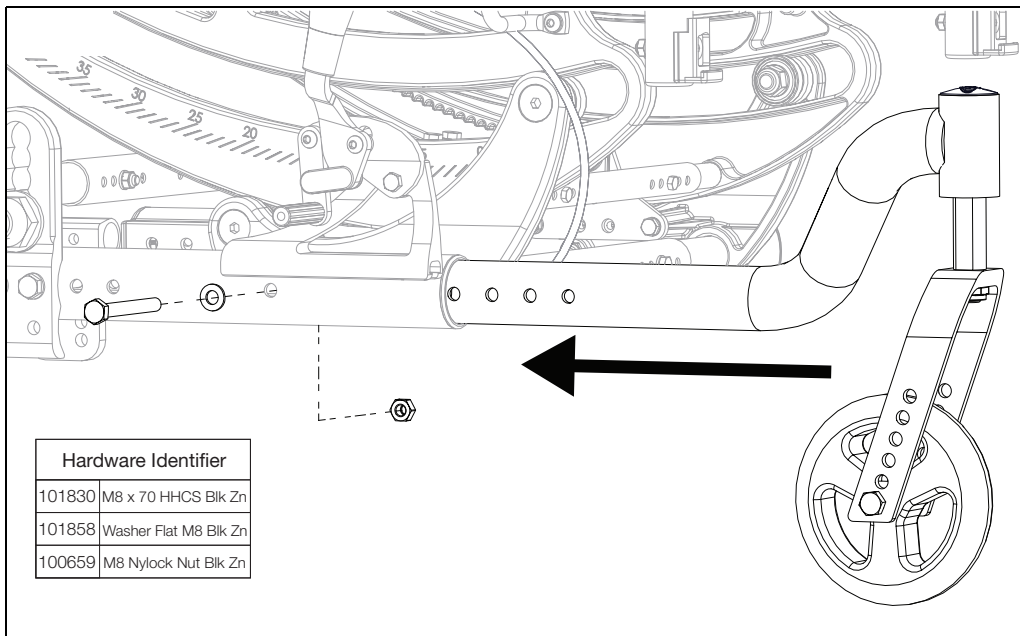

Wheel Lock Configurations

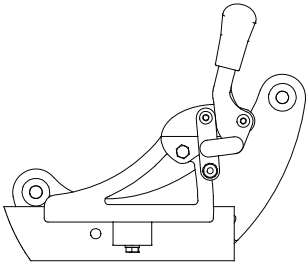
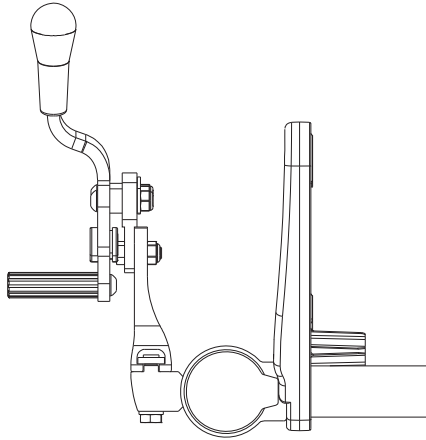

Plate: Front
Mount: Forward

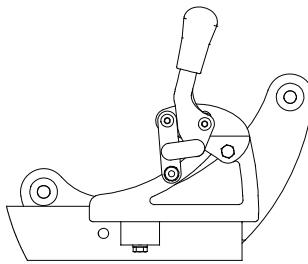

Plate: Front
Mount: Reversed

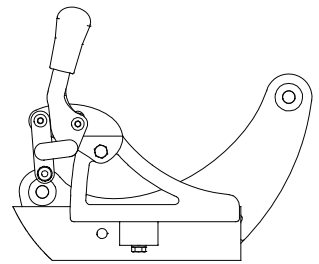
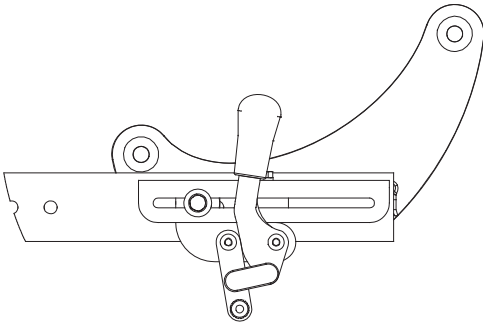

Plate: Rear
Mount: Reversed

Wheel Locks

Wheel Size	Axle Plate Position	Wheel Lock Configuration
16 in.	1 - 2	Front - Forward
	3 - 5	Front - Reversed
	6 - 8	Rear - Reversed
18 in.	1 - 2	Front - Forward
	3 - 5	Front - Reversed
	6 - 8	Rear - Reversed
20 in.	1 - 4	Front - Forward
	5 - 7	Front - Reversed
	8	Rear - Reversed
22 in.	1	N/A
	2 - 5	Front - Forward
	6 - 8	Front - Reversed
24 in.	1 - 2	N/A
	3 - 6	Front - Forward
	7 - 8	Front - Reversed

Wheel Lock Configurations



Inverted Forward Mount

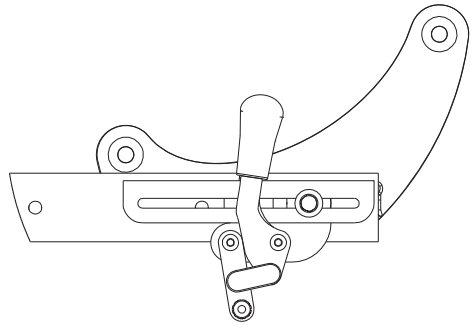

Inverted Reverse Mount

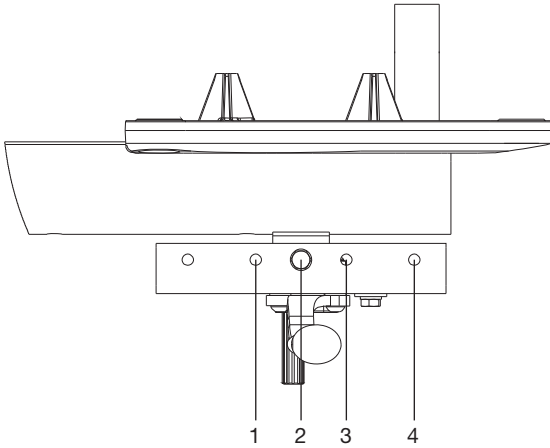

Inverted Mount Holes

Inverted Mount Wheel Locks

Wheel Size	Axle Plate Position	Mounting Configuration	Mount Hole
12 in. (Poly)	1	Reverse	2
	2	Forward	2
	3	Forward	3
	4	Forward	4
	5 - 8	Reverse	4
12 in. (Pneumatic)	1	Reverse	3
	2	Reverse	2
	3 - 4	Forward	3
	5 - 8	Reverse	4
16 in.	1	Forward	2
	2 - 3	Reverse	1
	4	Forward	2
	5	Forward	3
	6	Forward	4
	7 - 8	Reverse	3

Attendant Foot Lock

NOTE: Installing Focus Attendant Foot Lock Assemblies section is for chairs that are shipped without the foot lock installed. For instructions installing a Focus attendant foot lock from a kit, see the Focus Attendant Foot Lock Kit section.

Installing Focus Attendant Foot Lock Assemblies

1. Install foot linkage assembly (A) onto the wheel lock mount block (B) by sliding the T-slot nut (C) into the foot linkage assembly and securing with bolt (D) and lock washer (E) using a 10mm wrench.

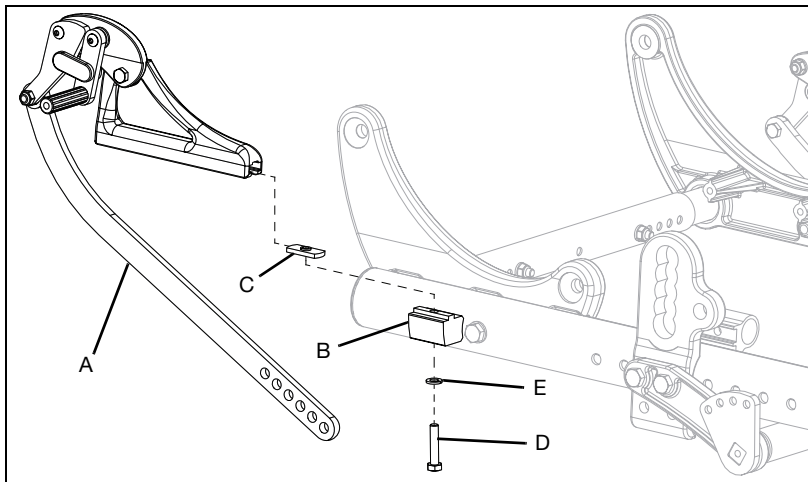

2. Secure foot linkage arm (A) to foot lock index plate (B) with flat head cap screw (C), two nylon washers (D), pivot bushing (E) and nylock nut (F) using a 4mm Allen wrench and a 10mm wrench.

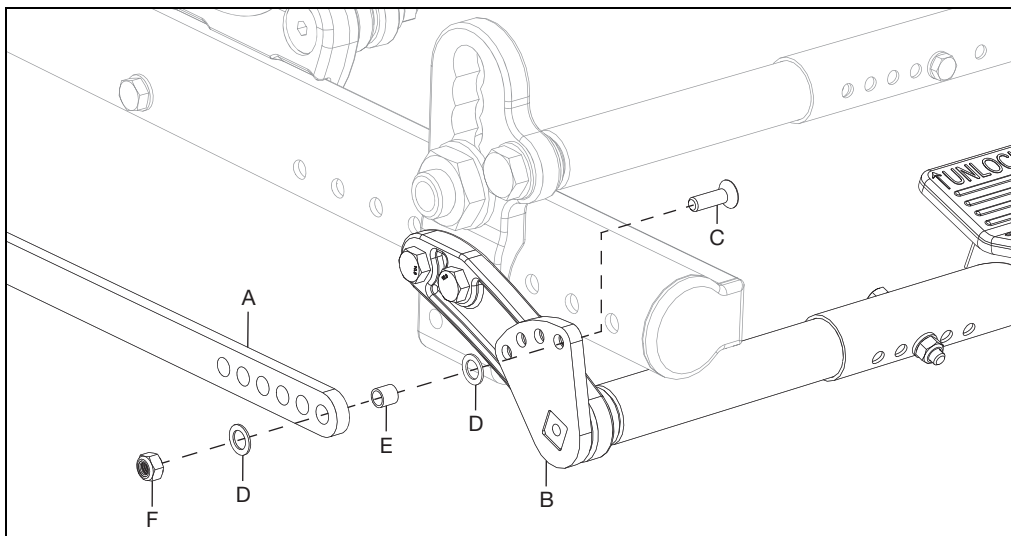

3. Repeat steps 1 and 2 on opposite side of chair.
4. Test wheel lock to ensure wheel lock arms embed in tires at least 1/8" when locked.

NOTE: Low pressure in tires may cause the wheel lock to slip and may allow the wheel to turn when you do not expect it. Ensure tires are properly inflated.

Attendant Foot Lock

Focus Attendant Foot Lock Kit

NOTE: Remove any existing wheel locks prior to installation. Converting from drum brakes requires a different kit. Please see the parts section at www.kimobility.com for more information.

1. Install tube mount (A) using two bolts (B), two washers (C) and two nuts (D) using two 13mm wrenches.
Repeat on opposite side.

NOTE: 90mm long bolts are used for standard chairs and 100mm long bolts are used for chairs that use foot tilt.

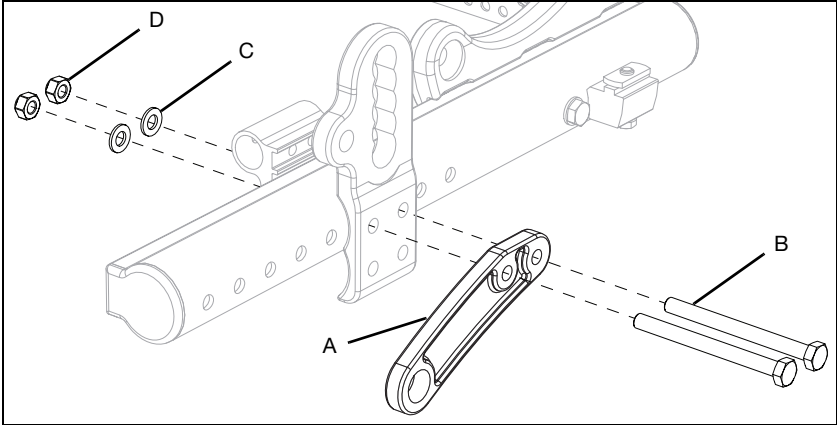

2. Install growth strut (A), strut (B), two bearings (C), index plate (D), fender washer (E) and bolt (F) using a 10mm wrench. Repeat on opposite side using opposite end of growth strut.

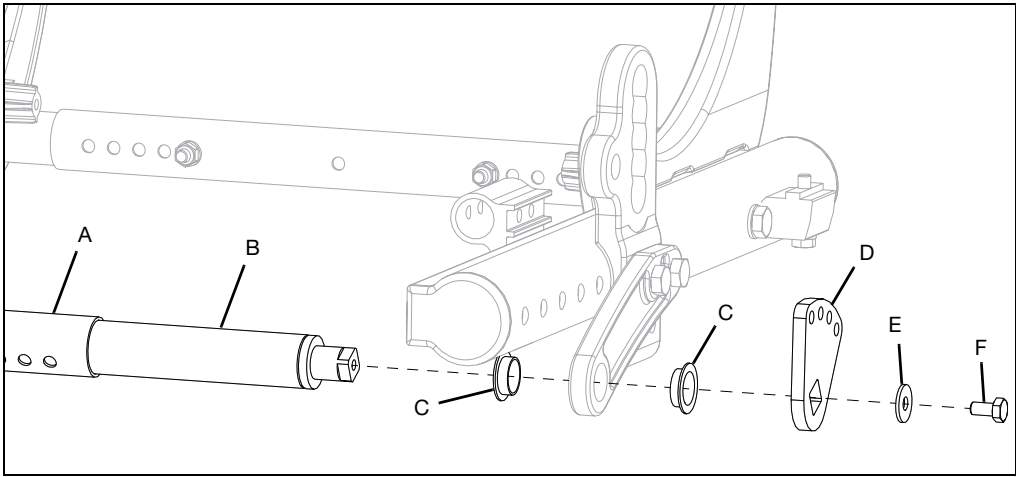

Attendant Foot Lock

3. Adjust growth strut to fit the width of your chair and secure with two bolts (A), two washers (B) and two nuts (C) using two 10mm wrenches.

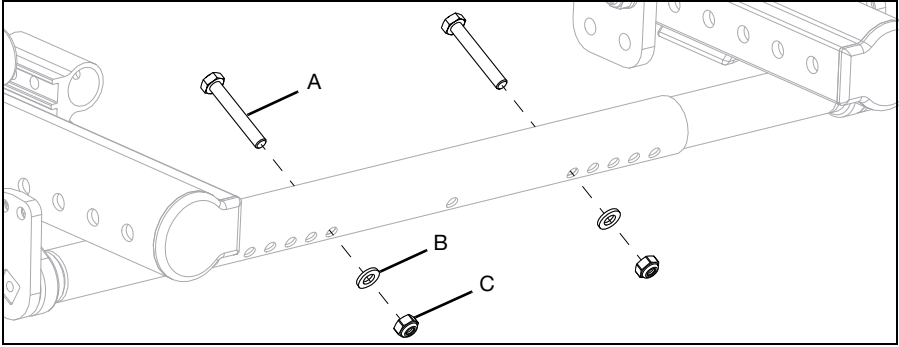

4. Install foot pedal (A) onto growth strut with bolt (B) and nut (C) using two 10mm wrenches.

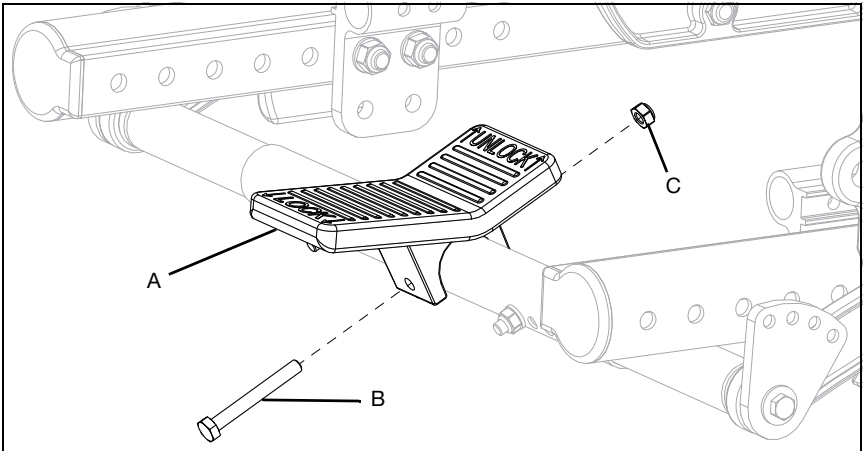

Attendant Foot Lock

5. Install wheel lock mechanism (A) onto foot lock linkage (B) with bolt (C), two washers (D), pivot bushing (E) and nut (F) using two 10mm wrenches. Repeat on opposite side. Note how there are different foot lock linkages that are used. The holes used for different configurations are shown below.

NOTE: The combination attendant foot lock is shown on the right. The installation process is the same for the combination attendant foot lock, the only difference being the addition of a hand lever on the tilt mechanism for the chair user.

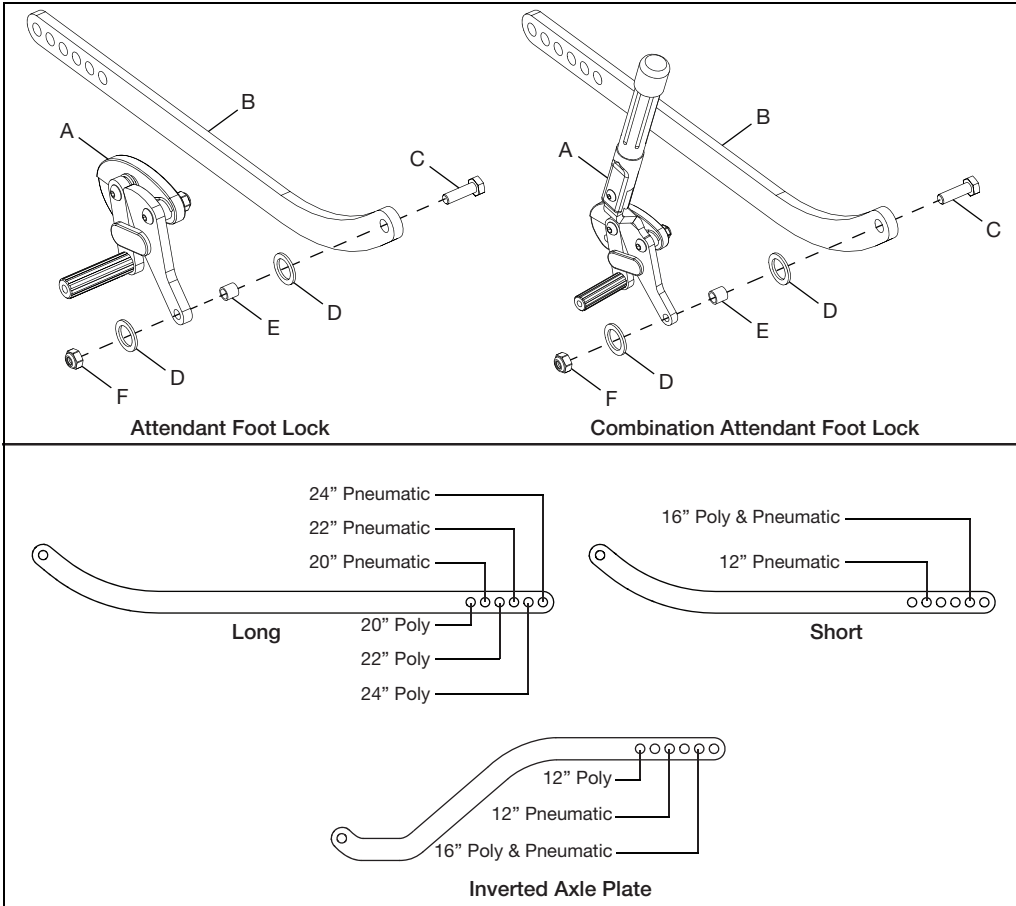

6. Install foot lock linkage / wheel lock mechanism assembly onto the wheel lock plate (A) with a bolt (B) and nut (C) using two 10mm wrenches.

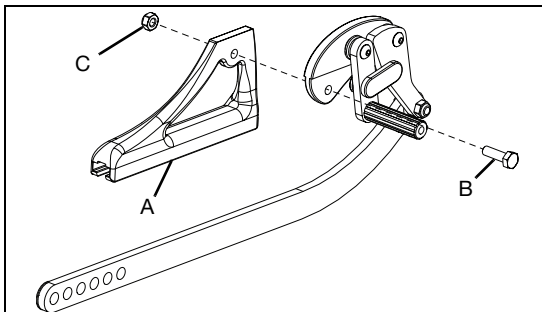

Attendant Foot Lock

7. Install foot linkage assembly (A) onto the wheel lock mount block (B) by sliding the T-slot nut (C) into the foot linkage assembly and securing with bolt (D) and lock washer (E) using a 10mm wrench.

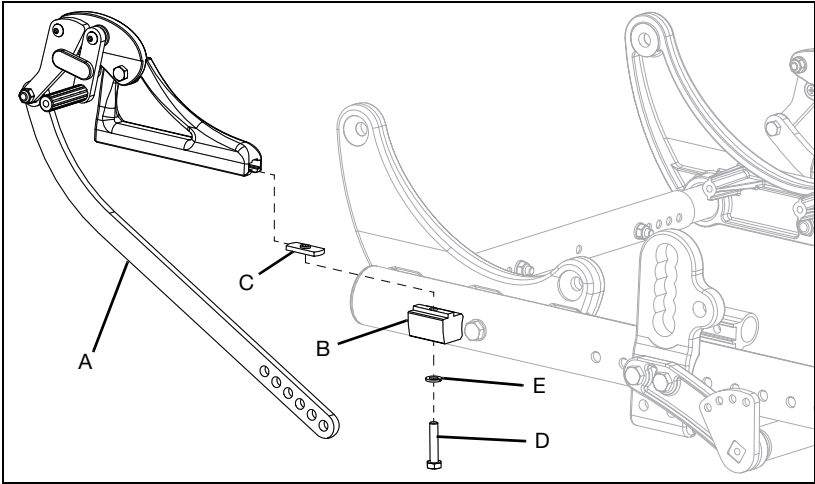

8. Secure foot linkage arm (A) to foot lock index plate (B) with flat head cap screw (C), two nylon washers (D), pivot bushing (E) and nylock nut (F) using a 4mm Allen wrench and a 10mm wrench. Repeat on opposite side.

NOTE: Use the hole in the index plate that allows the foot pedal to be in the desired angular position.

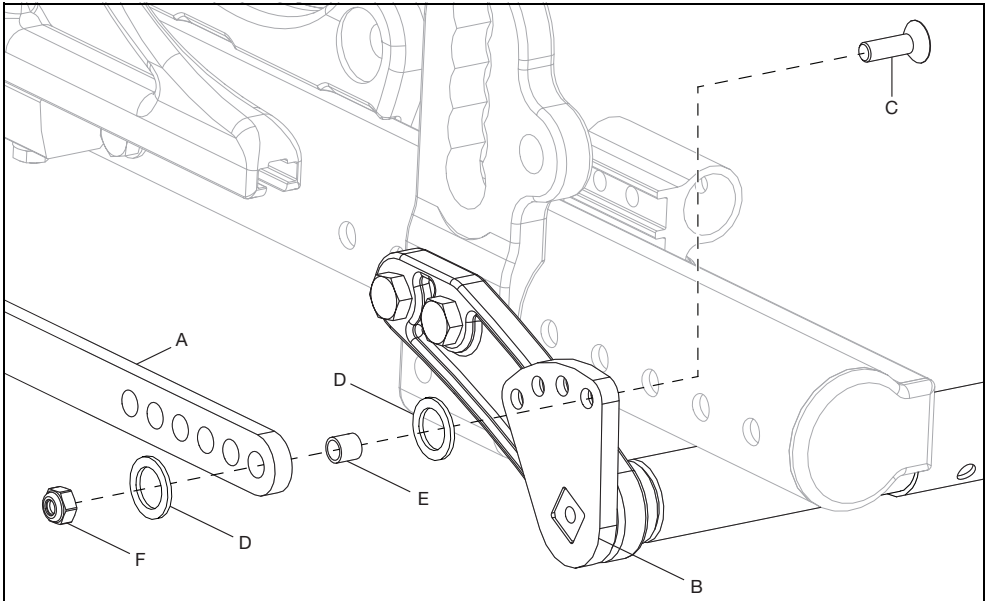

9. Test wheel lock to ensure wheel lock arms embed in tires at least 1/8" when locked.

NOTE: Low pressure in tires may cause the wheel lock to slip and may allow the wheel to turn when you do not expect it. Ensure tires are properly inflated.

One Arm Drive

NOTE: When installing the one arm drive system, there are different height settings that can be used. Install using the correct settings for the user.

1. Remove both wheels from wheelchair.

NOTE: If your chair does not have an attendant wheel lock you can skip to step 3.

2. If your chair has an attendant wheel lock, access to the axle plate will be blocked by the wheel lock. Detach the linkage from the index plate using a 10mm socket wrench and a 4mm Allen wrench. Save the bolt, two washers, insert and nut. Repeat on opposite side.

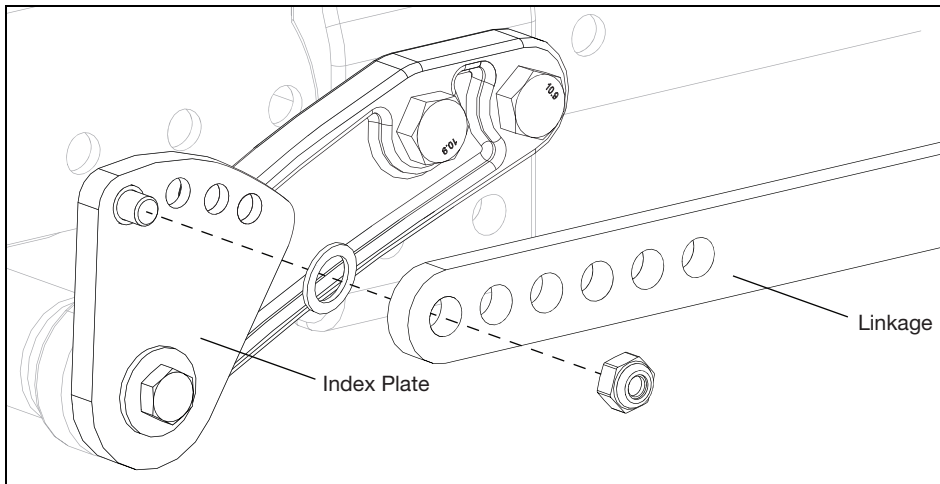

3. Remove the axle plates and axle plate strut tube by removing two bolts, two washers and two nylock nuts using a 13mm socket wrench and a 13mm wrench. Repeat on opposite side. Save all hardware and parts.

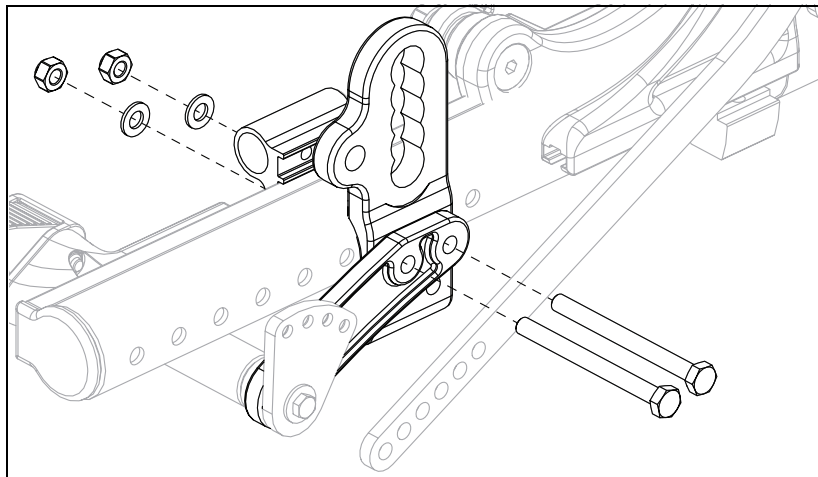

One Arm Drive

4. Install new axle mounts with two bolts, two washers and two nuts per side using a 13mm socket wrench and a 13mm wrench.

NOTE: When installing the new axle mounts, the bolts will pass through the tube mount and anti-tip bracket if the anti-tip and attendant wheel lock configurations are on your chair. These configurations will use a different longer bolt provided in your kit.

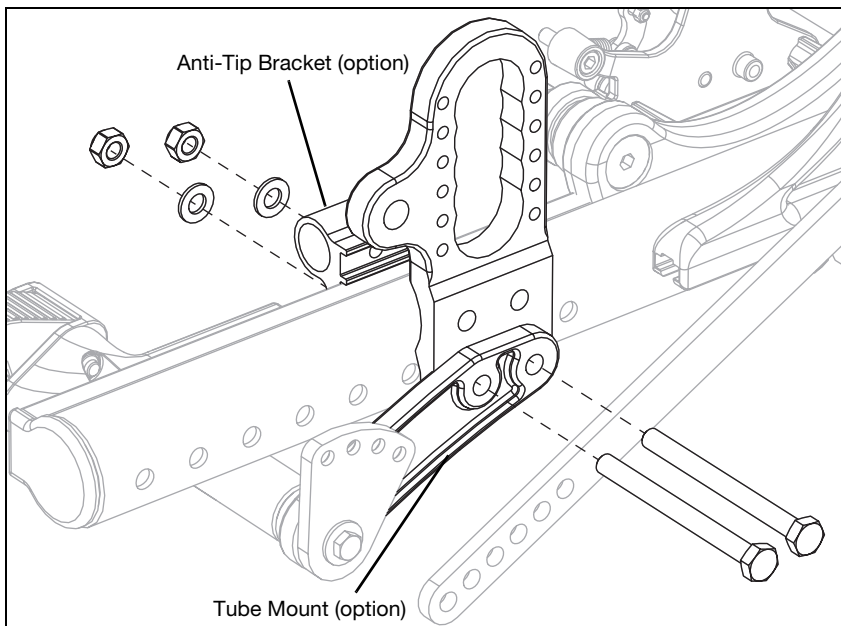

5. Install new drive shaft, axle shafts and bearing mounts. Install the bearing mounts using four bolts and four nuts per side using an 8mm wrench and a 4mm Allen wrench.

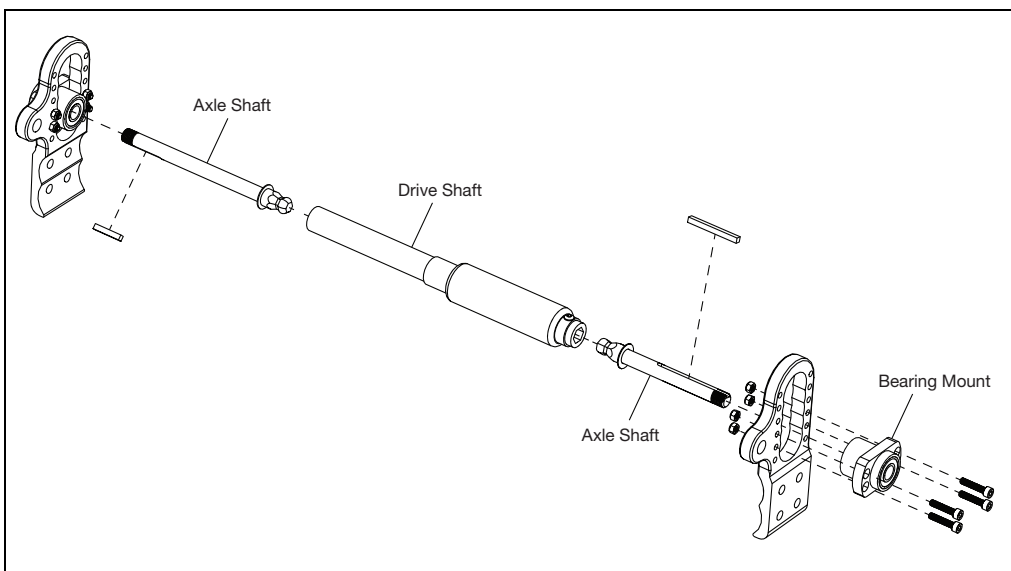

One Arm Drive

6. Bolt hub to handrim with four bolts provided if not already done.

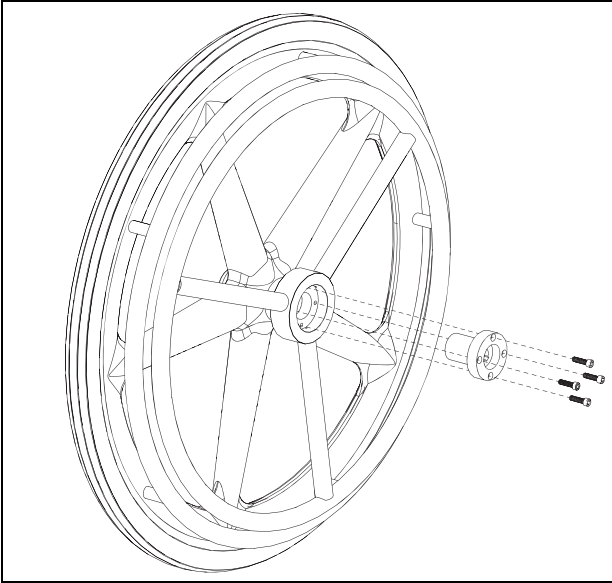

7. Install wheels and secure with washer and nut using a 19mm wrench.

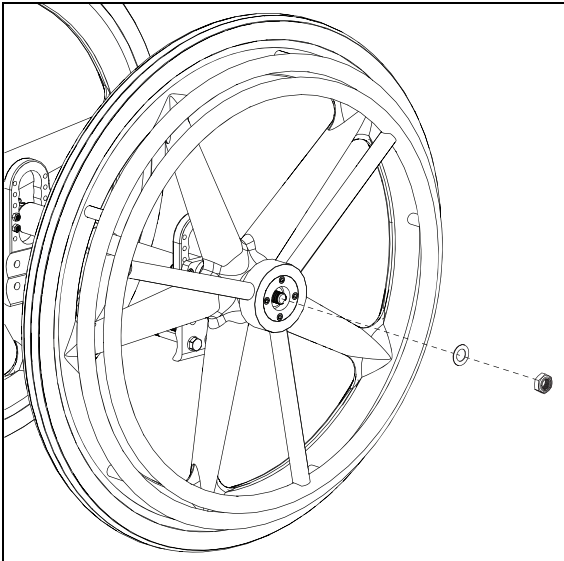

8. Reattach the linkage to the index plate with saved hardware from step 1.

NOTE: If you have an attendant wheel lock on your chair, verify the wheel lock still engages properly in a safe environment. Make adjustments to wheel lock if necessary.

Drum Brake

Remove Axle Plate

NOTE: An inverted axle plate has the same hardware removed and the same tools are used.

1. Remove wheel.
2. Using two 13mm wrenches, remove axle plate bolts (F), washers (B) and nuts (A) from both sides of chair. Note the orientation of the anti-tip receiver (C).
3. Use a 19mm wrench to remove the bolt (E) and washer (D) holding the strut tube to the axle plate.

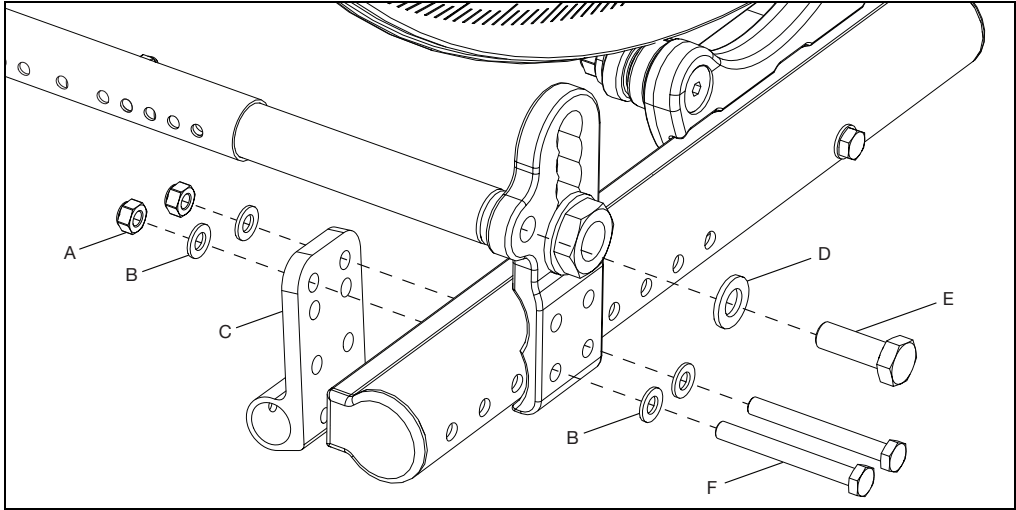

Install Drum Brake

1. Install new axle plate (D) with bolts (G), washers (B), nuts (A) and existing anti-tip receiver (C) using two 13mm wrenches.
2. Reinstall the bolt (F) and washer (E) to secure the strut tube to the axle plate using a 19mm wrench.

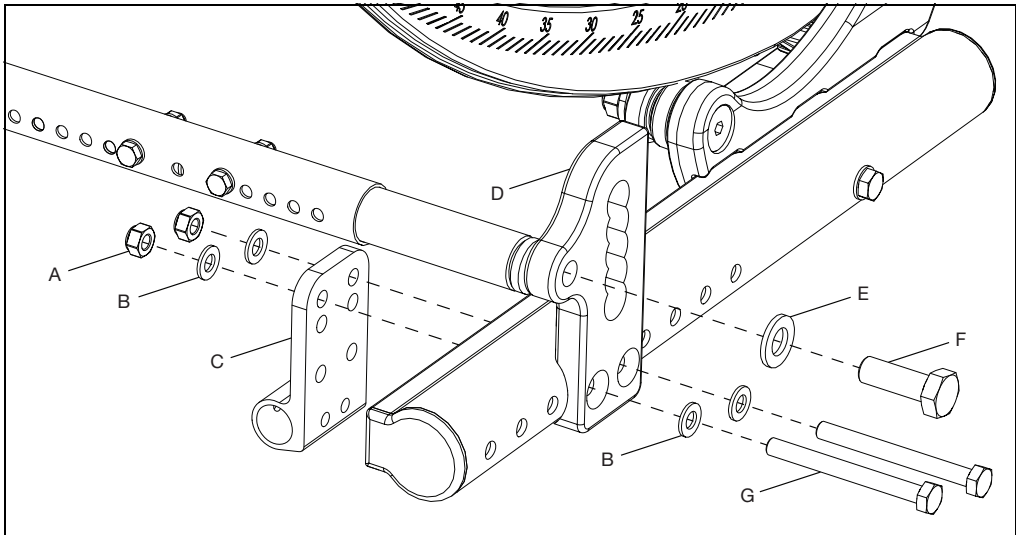

Drum Brake

3. Install drum brake (D), nut (A), drum brake adapter (C) and washer (B) using a 30mm wrench.

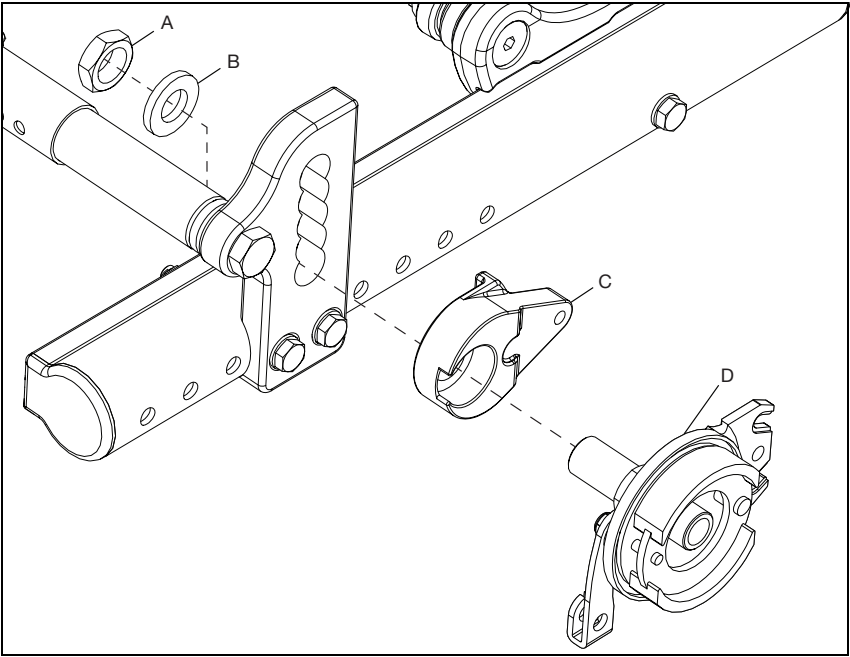

4. Secure drum brake and drum brake adapter by installing bolt (A), washer (B) and nut (C) using a 10mm wrench.

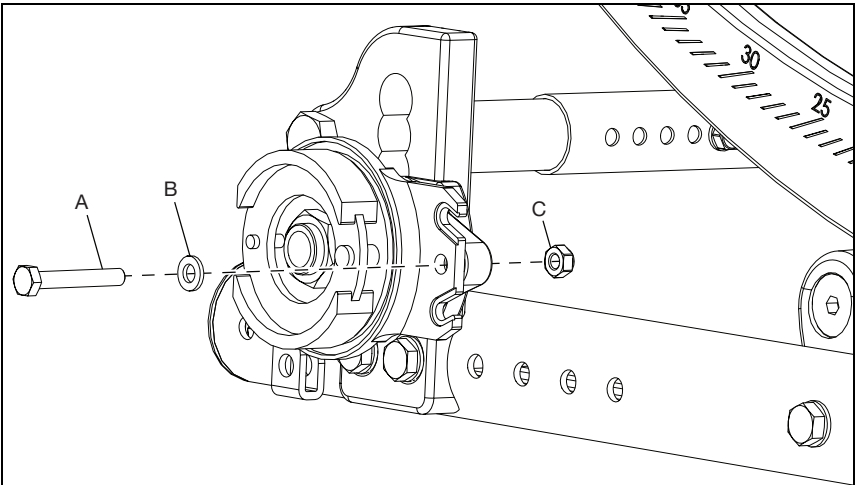

Drum Brake

5. For inverted axle plates with no other wheel locks mounted - Install wheel lock mount cover (A) with bolt (B), washer (C) and nut (D) using a 10mm wrench. Repeat on opposite side.

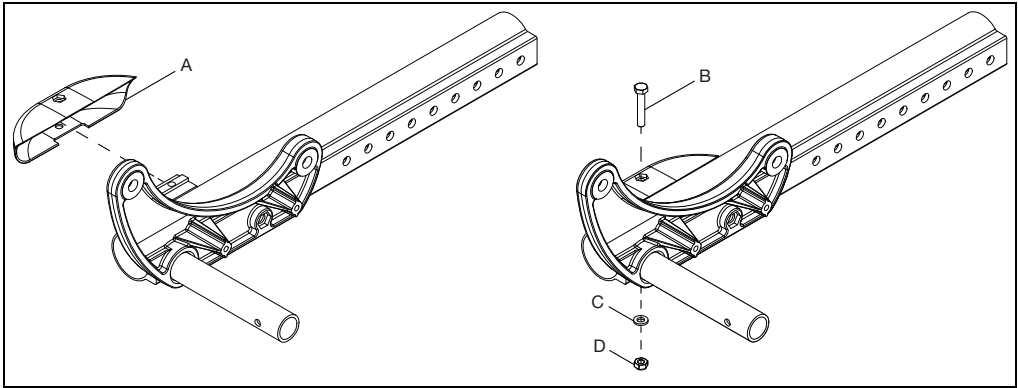

6. For fixed height backrest - Remove existing backrest cane and install new backrest cane by removing and reinstalling bolt using a 4mm Allen wrench.

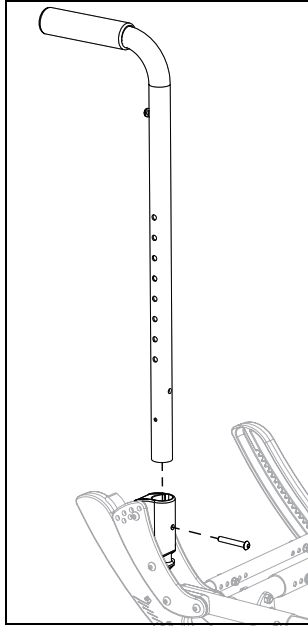

Drum Brake

7. Install hand trigger (Fig. 7:B) by installing two screws (Fig. 7:A) using a #2 screwdriver.

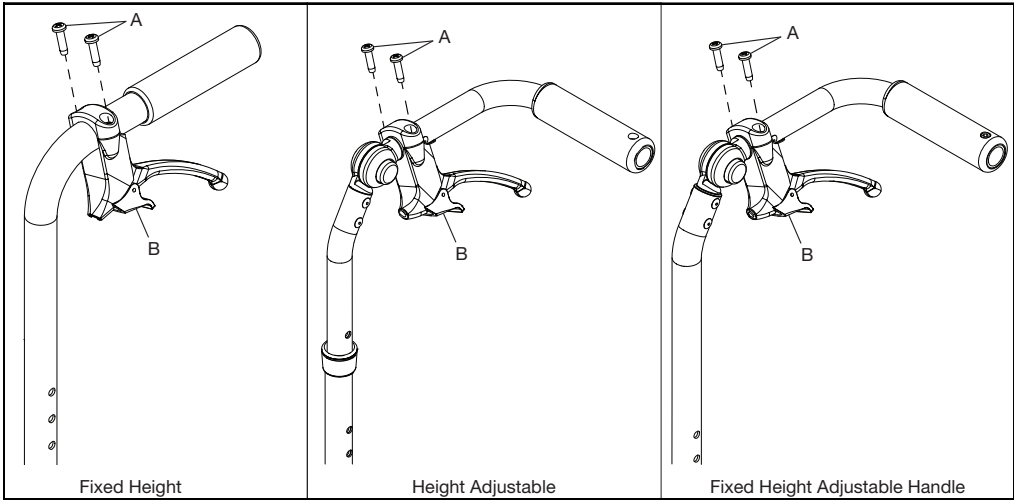

8. Install the cable into hand trigger. Remove the stranded cable core from the cable and thread it through the trigger of the trigger assembly and then out the nose of the trigger mount. Then, rethread the stranded cable core through the cable jacket with the metal fitting at the end of the jacket set into the nose of the trigger mount.

9. Route cable along back cane and secure with two 1" cable clips (A). For a height adjustable back, use one 7/8" cable clip (B) and one 1" cable clip (A).

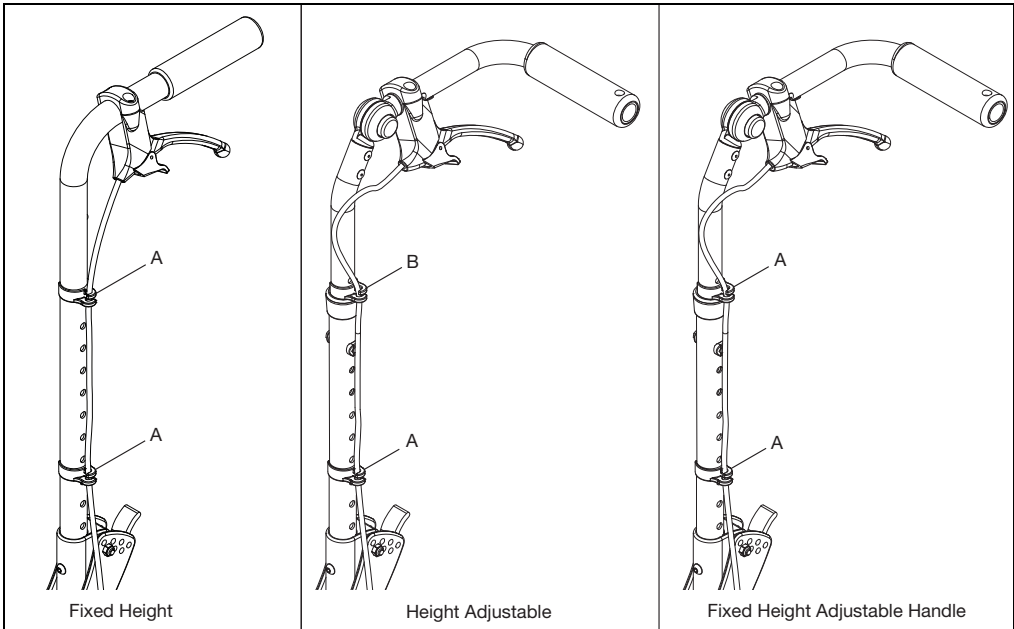

Drum Brake

10. Route cable to back plate and install cable into P-Clip (B) by removing and reinstalling nut (A) using a 10mm wrench.

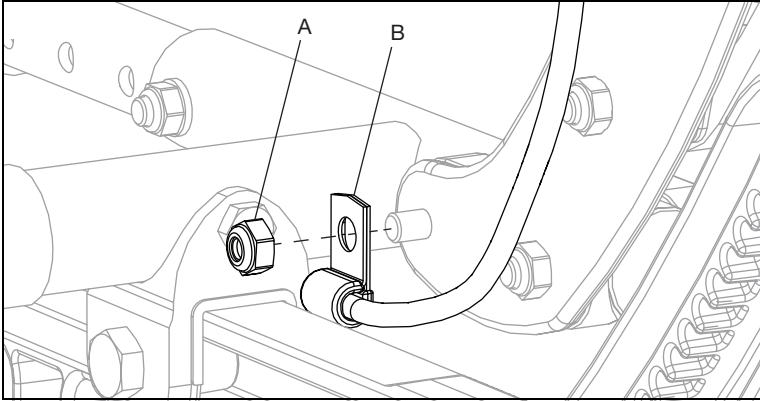

11. Route cable from P-Clip to drum brake. Ensure the path is a smooth loop with no sharp turns or kinks in the cable. Thread stranded cable core through pinch bolt (A) as shown. Install barrel (B) into slot as shown. Remove slack from cable core and tighten pinch bolt onto cable core. Do not tighten jam nut (C).
12. Install wheel and test the drum brake. If needed, unlock the jam nut and unthread the adjuster (D) to get tighter braking action or thread adjuster in to reduce braking action. Retighten jam nut to lock the adjustment in place.

NOTE: It is recommended to adjust the brake until there is a slight bit of drag on the wheel when spun. Then, thread the adjuster inward about ½ turn, or whatever is necessary to remove all drag from the spinning wheel.

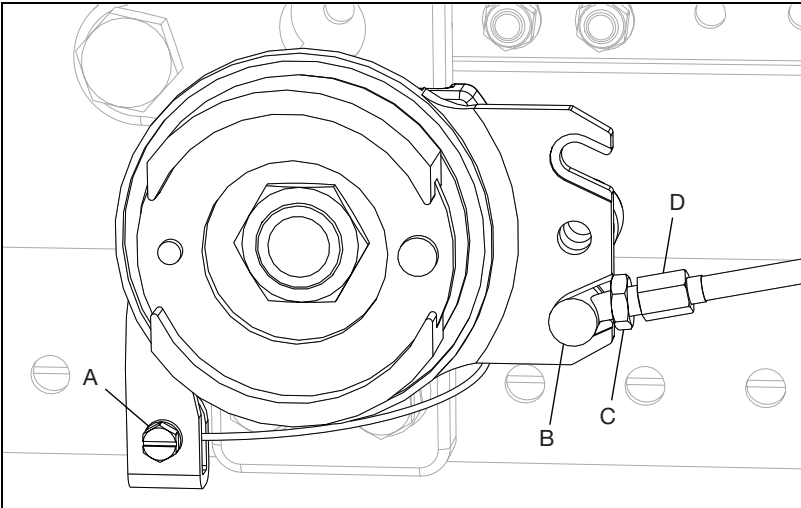

13. Repeat process on opposite side.

Handrim Configurations

NOTE: Not all wheels listed below are available for specific models. See an order form or the online parts manual for more information on your specific chair model.

Handrim Hardware Chart														
Wheel		Handrim Connection				Handrim								
Wheel	Wheel Part Number	Connection Points	Tab	Spacer	Screw	Aluminum Anodized	Superlight	Plastic Coated	Projection	Natural Fit Standard	Natural Fit LT	Flex Rim		
18" Ki Spoke	200529	3	100698	100653	Aluminum, Plastic Coated, Projection: 100654 Natural Fit: 100835	100206		101106						
20" Ki Spoke	200530	6						200536		200542				
22" Ki Spoke	200531							100560		100576	100569	200538	200201	
24" Ki Spoke	200532							200349		100577	200547	100793	200202	
25" Ki Spoke	200533							200350		101870	200548	200539	200540	
26" Ki Spoke	200534							200351		100578	200549	100907	101454	
20" 5-Spoke X Core	101961	5		Aluminum, Projection, Natural Fit: 100629	100724	101897		101963						
22" 5-Spoke X Core	101962						101898		101964					
24" 5-Spoke X Core	100960			Plastic Coated: 101756		100975		100976	200546					
24" 5-Spoke X Core	100960					101893					100768	100769		
20" Spinery Spox	See Spinery Spox Page	6			Screw: 100669 Nut: 100657	103125		103179						
22" Spinery Spox						100827		100808		100889	100888			
24" Spinery Spox						100766	101161	100615		100830	100828			
25" Spinery Spox						100767	101160	100765		101464	101460			
26" Spinery Spox						101477		101148		200200	100950			
22" Spinery LX	See Spinery LX Page	6			Screw: 100669 Nut: 100657	100827		100808		100889	100888			
24" Spinery LX						100766	101161	100615		100830	100828	200213		
25" Spinery LX						100767	101160	100765		101464	101460	200208		
26" Spinery LX						101477		101148		200200	100950			

Handrim Construction

The sequencing of hardware for the three styles of handrims is shown below. The specific hardware used is determined in the chart on the previous page, based on the tire and handrim being used.

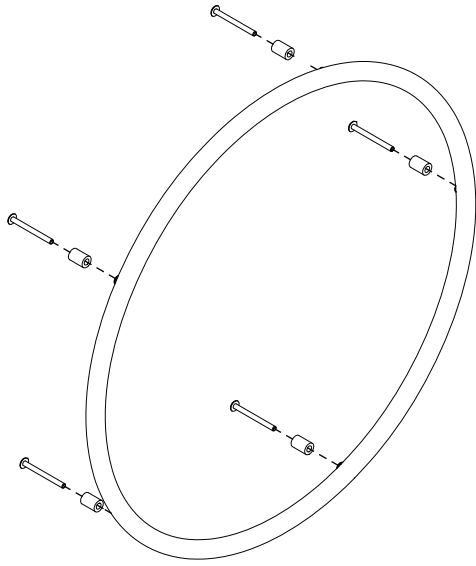

Spacer Style

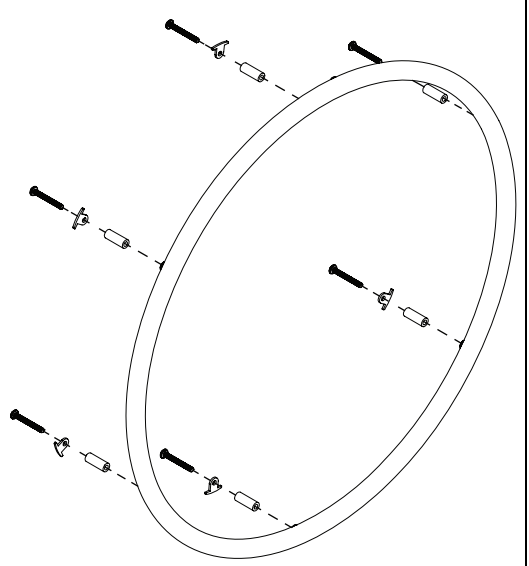

Detached Tab Style

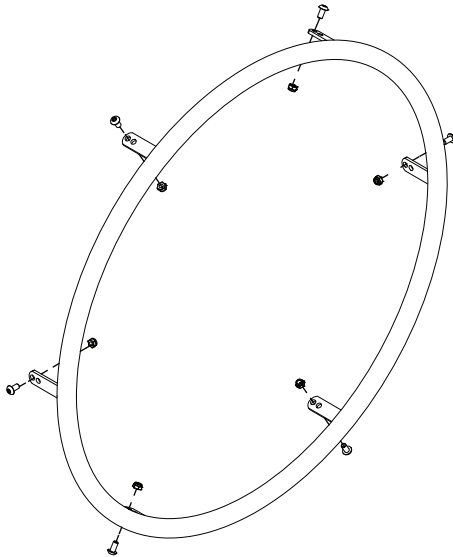

Tab Style

Footplate and Heel Loops

For additional footplate information, see pages 16 - 20 for the Caster - Footplate Compatibility Charts.

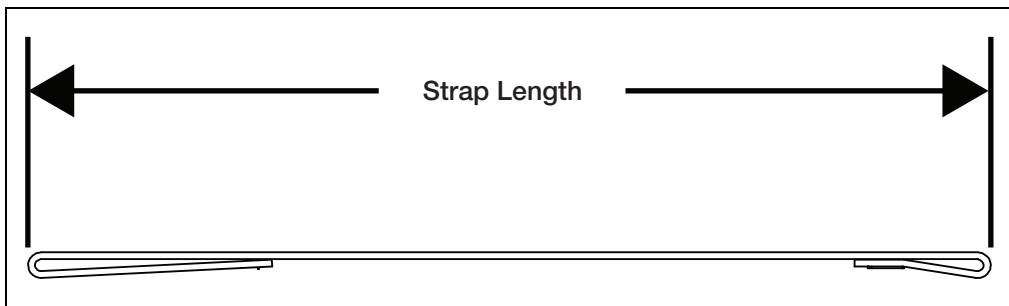

Heel Loop (Reference image above)								
Size	Part Number	Standard Hanger			Offset Hanger			Strap Length
		Angle Adjustable	Composite	Composite Angle Adjustable	Angle Adjustable	Composite	Composite Angle Adjustable	
Short	100591	N/A	14" - 15"	N/A	N/A	N/A	N/A	9.4"
Medium	100592	14" - 15"	16" - 17"	15" - 16"	N/A	14" - 15"	15" - 16"	10.4"
Long	100593	16" - 22"	18" - 22"	17" - 22"	16" - 22"	16" - 22"	17" - 22"	11.4"

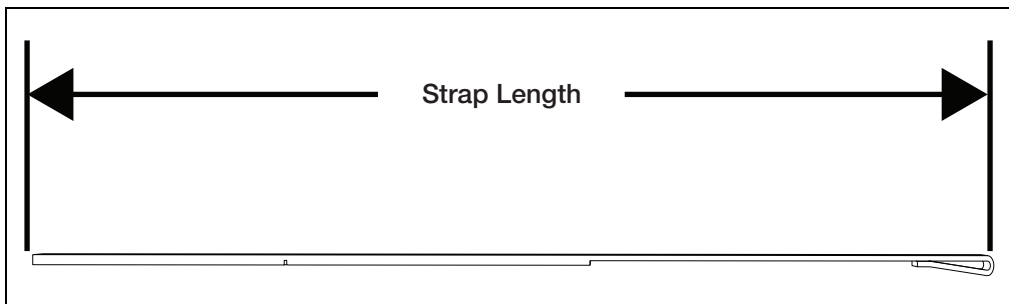

Adjustable Heel Loop (Reference image above)								
Size	Part Number	Standard Hanger			Offset Hanger			Strap Length
		Angle Adjustable	Composite	Composite Angle Adjustable	Angle Adjustable	Composite	Composite Angle Adjustable	
Short	103364	14" - 17"	14" - 18"	14" - 17"	N/A	14" - 16"	N/A	19"
Medium	103365	18" - 20"	19" - 22"	18" - 20"	16" - 18"	17" - 22"	16" - 18"	21"
Long	103366	21" - 22"	N/A	21" - 22"	19" - 22"	N/A	19" - 22"	25"

Rotating 4-Way Latch

The 4-Way latch has eight possible configurations, four with the curve of the lever facing outward and four with the curve of the lever facing inward. See diagram below.

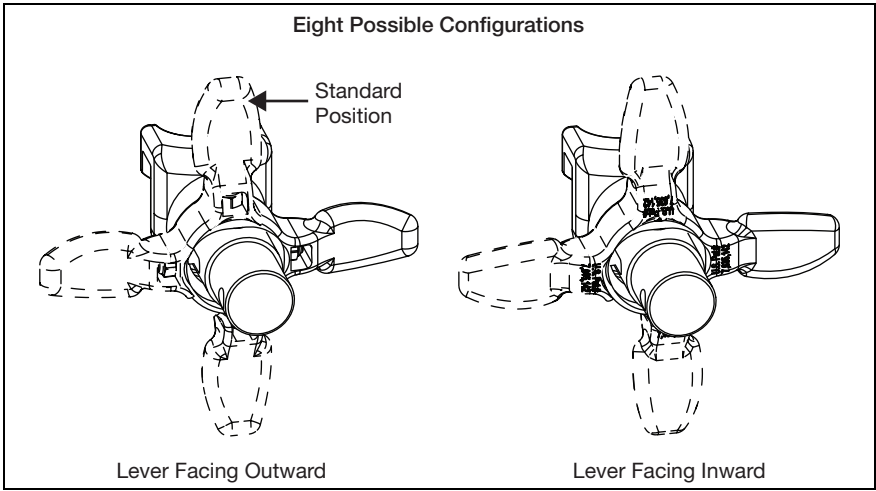

Rotating

1. To rotate the 4-Way Latch, remove the screw using a 3mm Allen wrench while the hanger is still on the chair (spring must be engaged to remove and reinsert screw and keeping the hanger on the chair keeps the spring engaged.) Ensure the nut does not fall out.
2. Rotate the 4-Way Latch to desired orientation and reinsert screw with a 3mm Allen wrench. Ensure that the nut stays in position while tightening the screw. Do not overtighten screw or mechanism will bind.

NOTE: To reverse the 4-way latch, the same screw is removed, but the hanger has to be removed from the latch block. Once removed, slide the latch off, flip over and reinstall. Ensure spring is engaged, by pushing and holding the latch button in, and nut stays in position while reinstalling the screw.

NOTE: In-line position is not achievable with the Pro ELR Footrest option.

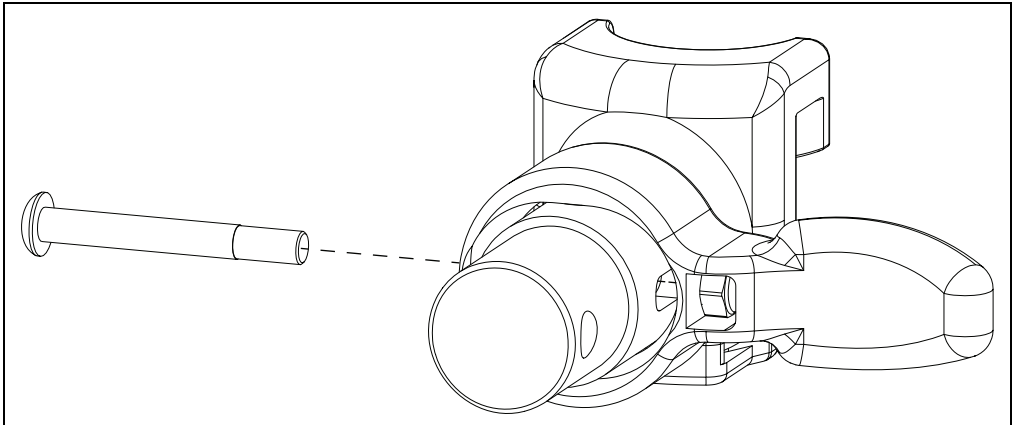

Pro ELR Adjustment

NOTE: Instructions for adjusting the height of the calf pad, the depth of the calf pad and the length of the footrest can be found in the owner manual in the Pro Elevated Leg Rest section.

Adjusting Knee Height

1. Using two 10mm socket wrenches, loosen the two nuts (A) on the cover.
2. Adjust knee height to desired setting.
3. Retighten the two nuts (A) after desired height is attained.

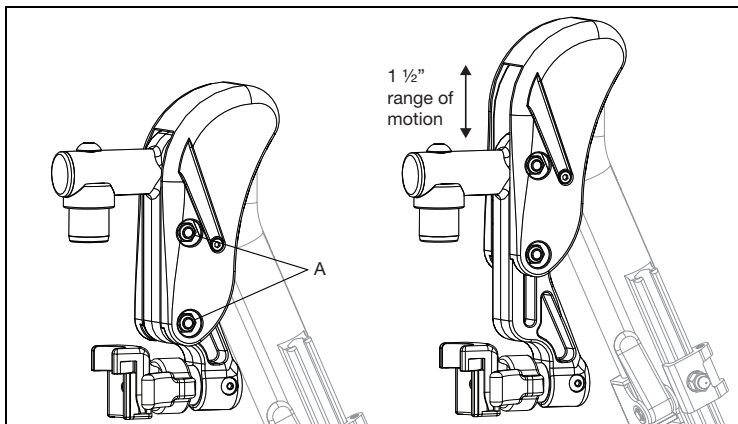

Adjusting Height Adjustable T-Arm Position

1. Remove two screws, two washers and two nuts from armrest receiver using a 4mm Allen wrench and a 10mm wrench.

NOTE: Some configurations will also have a spacer.

2. Move receiver to desired location on seat frame and reinstall screws, washers and nuts.

NOTE: If screws for armrest receiver coincide with seat frame screws, remove seat frame screws and replace with armrest receiver screws.

NOTE: If one of the armrest receiver screws lies on the center growth section of the seat frame, use the spacer around the growth tube at the mounting hole location.

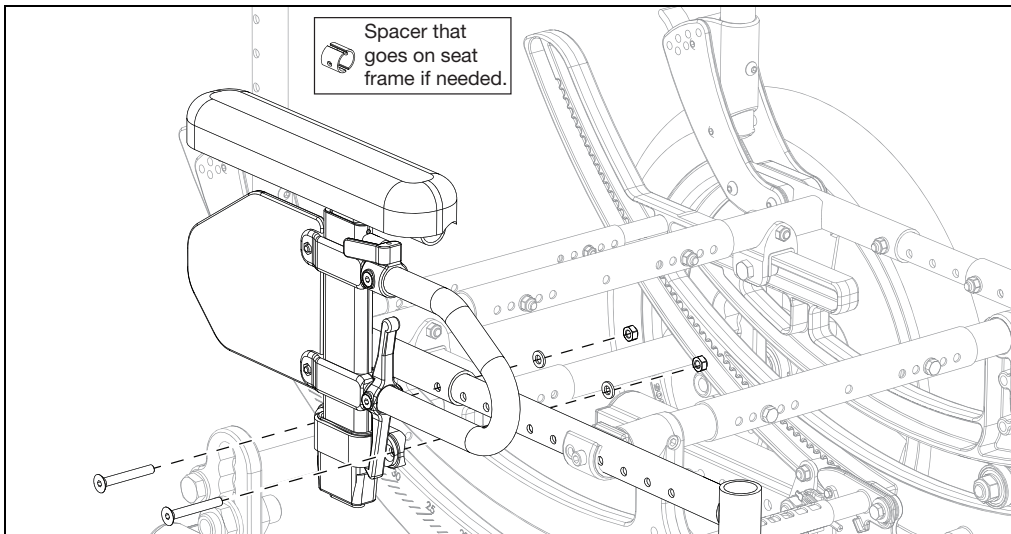

Angle Adjustable Locking Flip Up Extendable Armrest

1. Set the angle of the armrest. There are five holes that can be used to set the angle. Tighten the bolt using a 10mm wrench once angle is set.

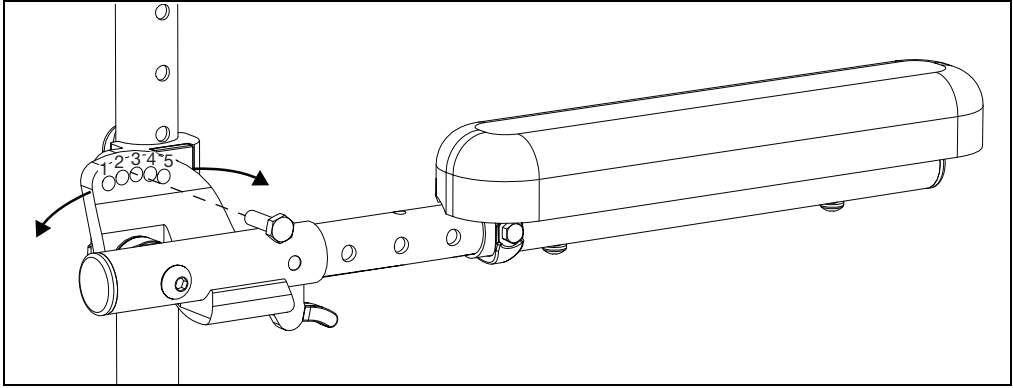

2. Set the length of the armrest. To adjust the length, remove the bolts and spacer on the tube and the screw closest to the back of the chair using a 10mm wrench and a Phillips screwdriver. Slide the armrest to desired length available by the predrilled holes and reinstall the screw and bolts.

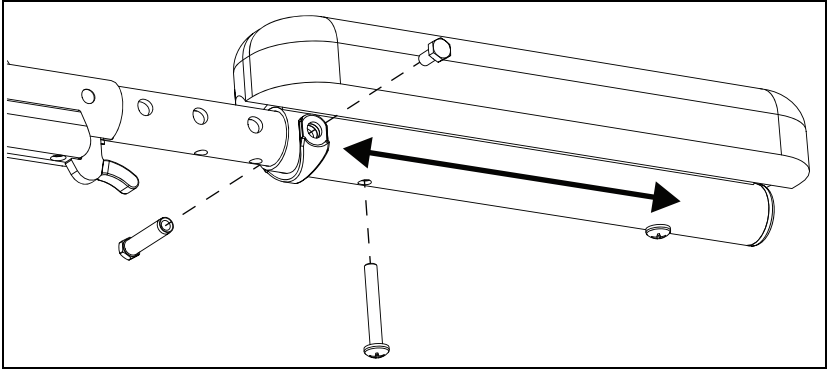

3. Set the height of the armrest. There are four holes on the armrest that allow for two different height settings for each set of holes on the back tube. Use the holes that provide the correct height setting for the user. The two bolts pass through the spacer, sleeves, back posts and into the armrest using a 4mm Allen wrench.

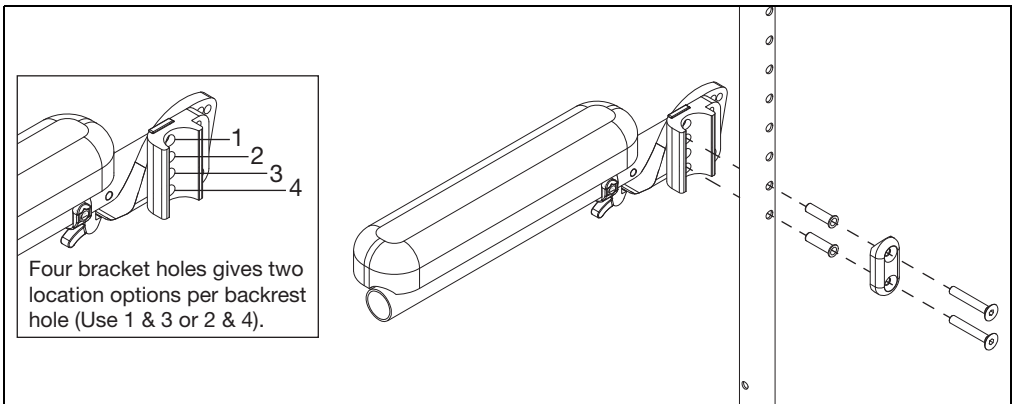

Bearing Construction

There are two sets of bearings used within the tilt function of the Focus chair. Use a 17mm wrench and a 6mm Allen wrench to remove and/or assemble the bearings. See diagram below for sequencing of parts.

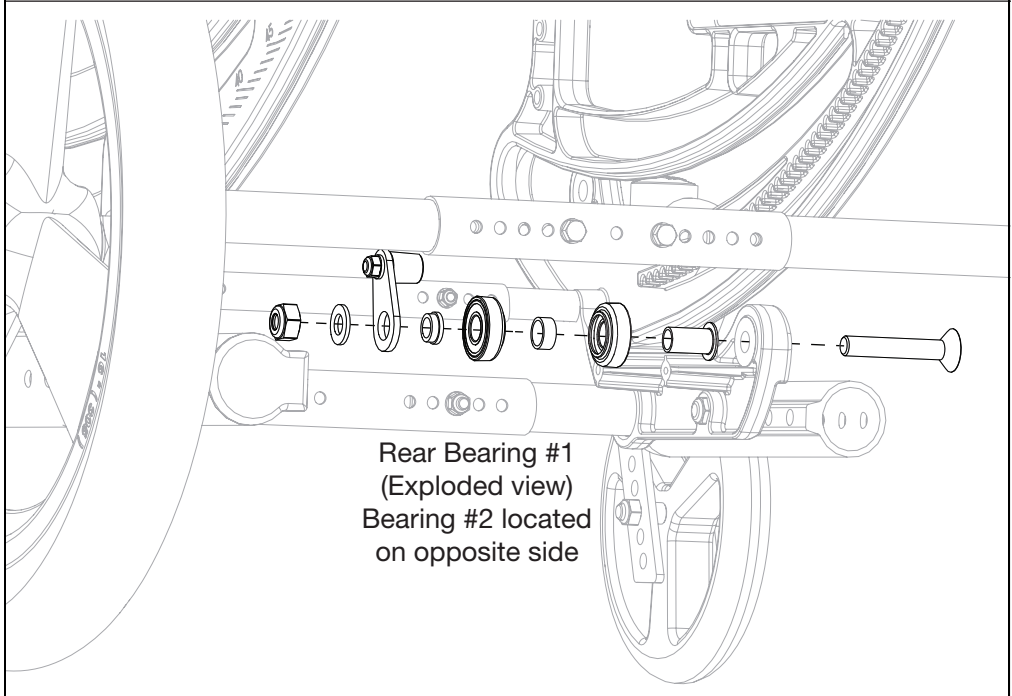
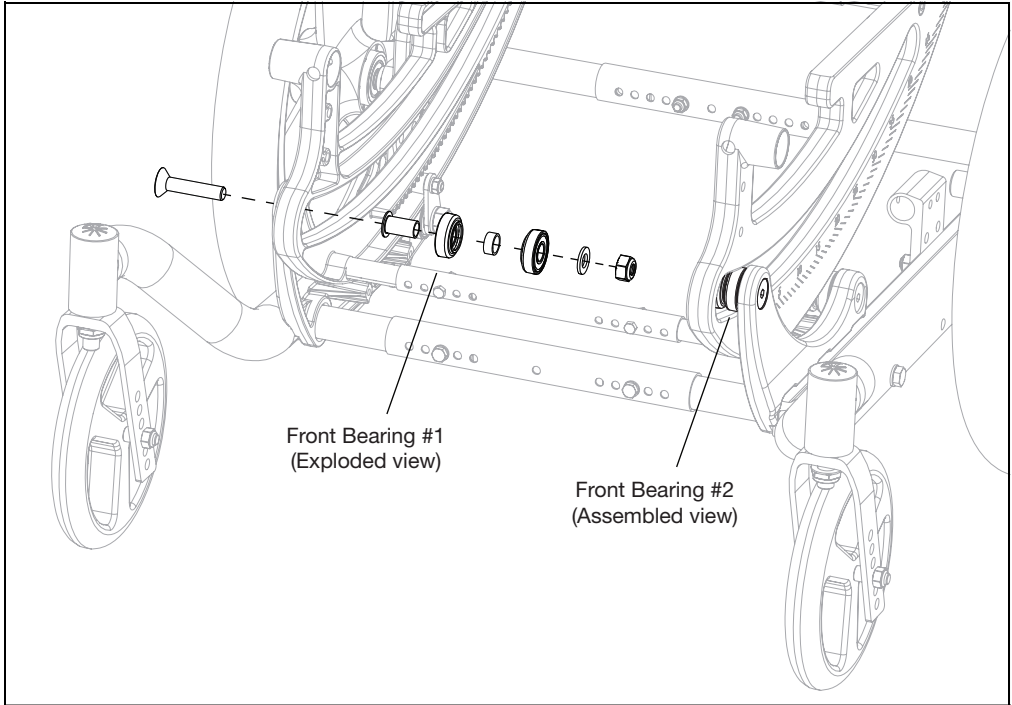

IV Holder

1. Place the two hole clamps (A) with the barrel nut (B) and screw (C) using a 5mm Allen wrench. Ensure the sides of the clamp with the flats are used on the backrest tube. Turn the screw (C) finger tight into the barrel nut (B).

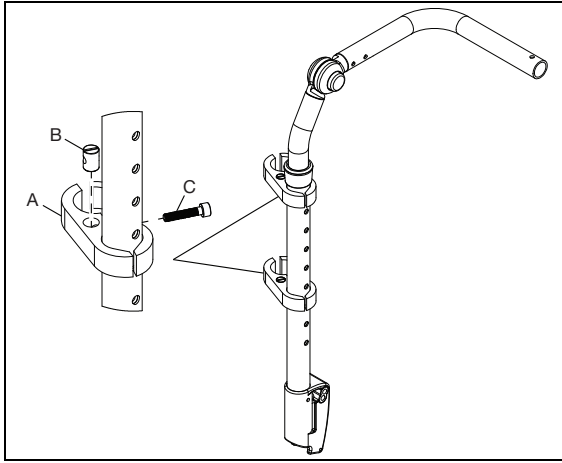

2. From the top, slide the IV pole assembly into the two clamps and tighten the clamp screws to secure pole.

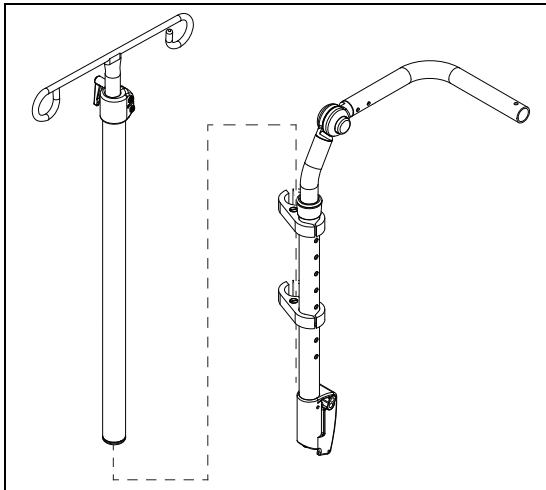

3. Turn the handle (A) to adjust the height of the IV pole.

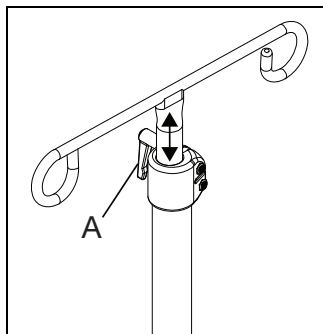

Vent and Battery Tray

Installation Instructions

1. Remove the base frame plugs (A) from both sides using a screwdriver. Be careful not to scratch paint.

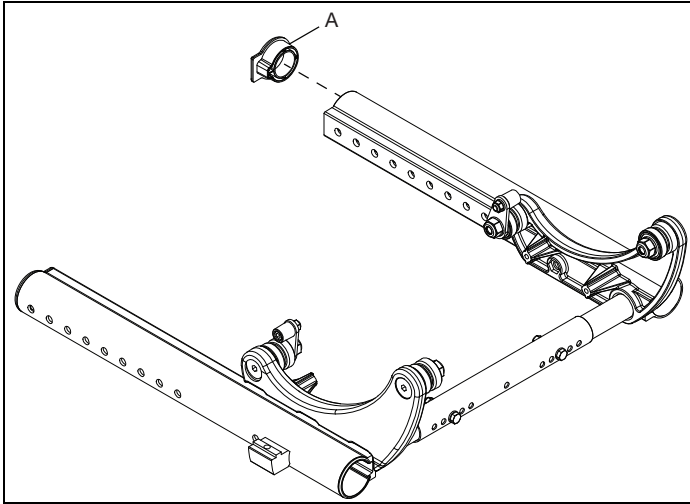

2. Install vent tray hanger (B) onto vent tray (A) with two washers (C) and two nuts (D) using a 10mm wrench. Repeat with other vent tray hanger and vent tray.

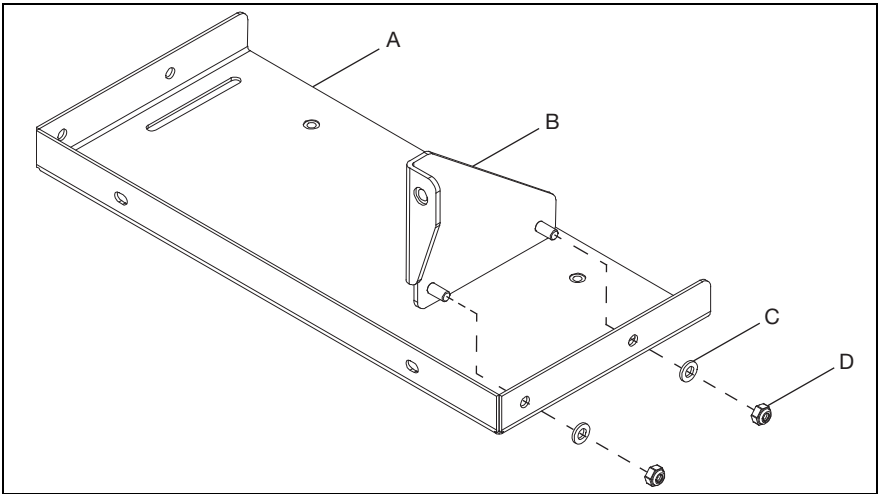

Vent and Battery Tray

3. Install end cap (D) onto anti-tip and install anti-tip (C) onto vent tray with bolt (G), spacer (F), saddle (E) and nut (B) using two 10mm wrenches. While installing, insert lower anti-tip tube (A) and set height based on which hole you use. Repeat process on opposite vent tray.

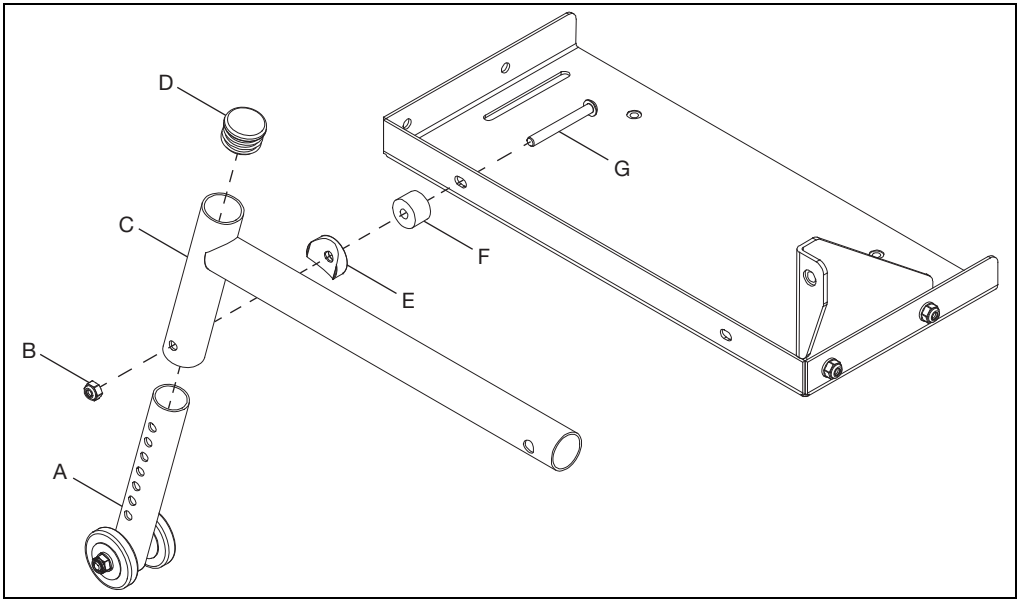

4. Install vent tray assembly onto chair frame by installing bushing (D) into frame. Secure anti-tip to bushing/frame with a lock washer (B), flat washer (C) and a bolt (A) using a 13mm wrench.

NOTE: The bolt goes through the frame tube, bushing, anti-tip and then back out and ending in the vent tray hanger.

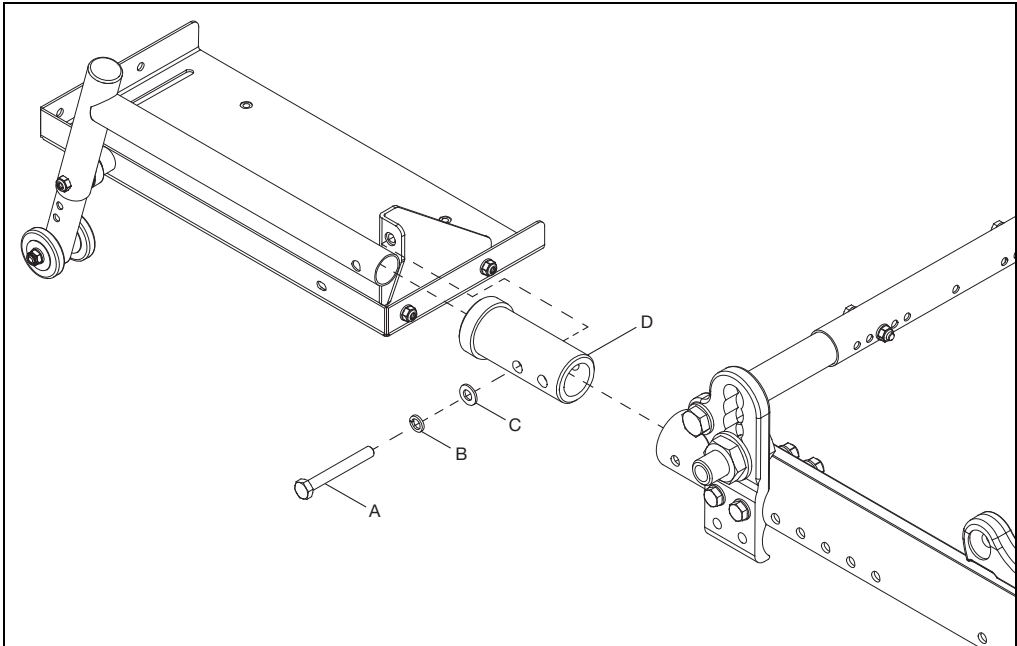

Vent and Battery Tray

5. Install growth plate (A) into the the vent trays with four screws (B) using a 4mm Allen wrench.

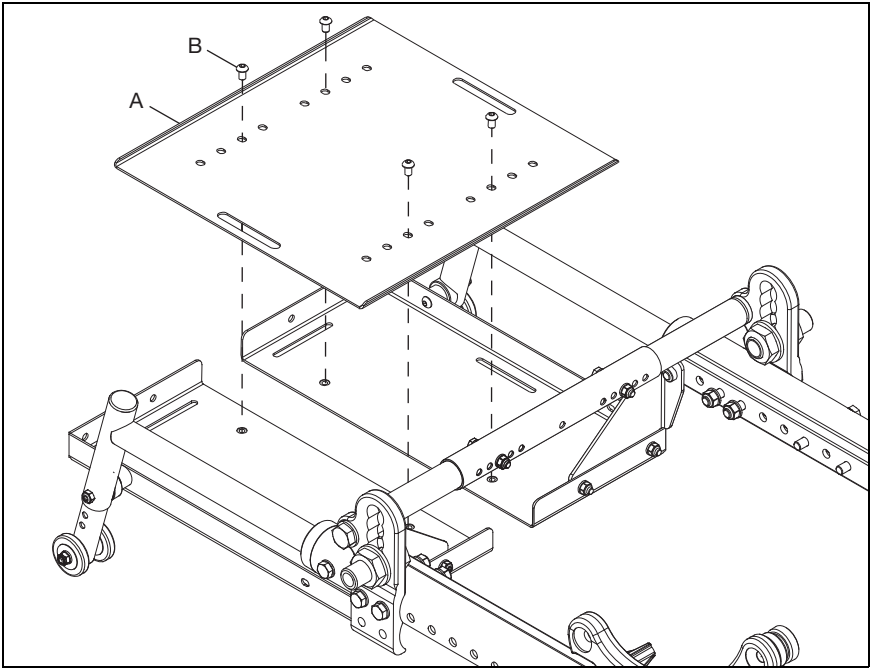

6. Install battery tray frame mount (D) onto battery hanger (C) with two bolts (A) and two washers (B) using a 10mm wrench. Repeat with other battery tray frame mount and battery hanger.

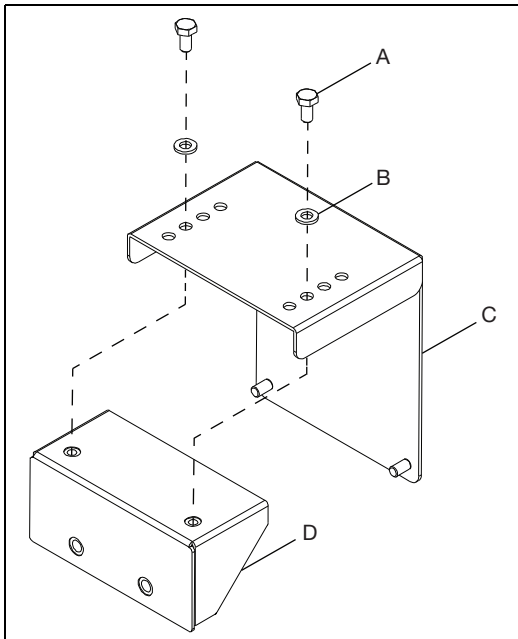

Vent and Battery Tray

7. Install battery hanger assembly into the battery tray (A) and secure with two washers (B) and two nuts (C) using a 10mm wrench. Repeat on opposite side of battery tray with other battery hanger assembly.

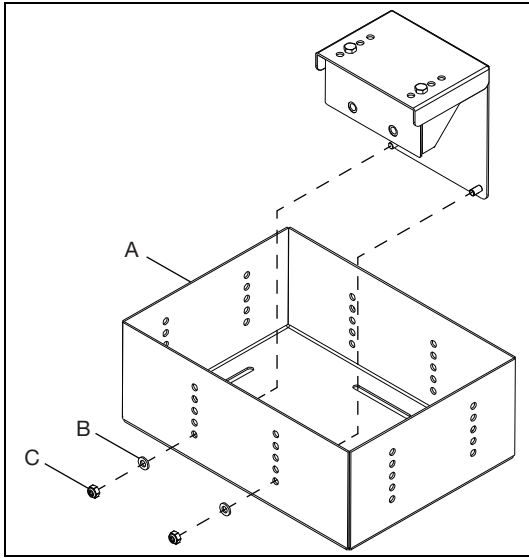

8. Install battery tray assembly onto frame with four bolts (A), four lock washers (B) and four washers (C) using a 13mm wrench. Ensure both sides are mounted using the same configuration.

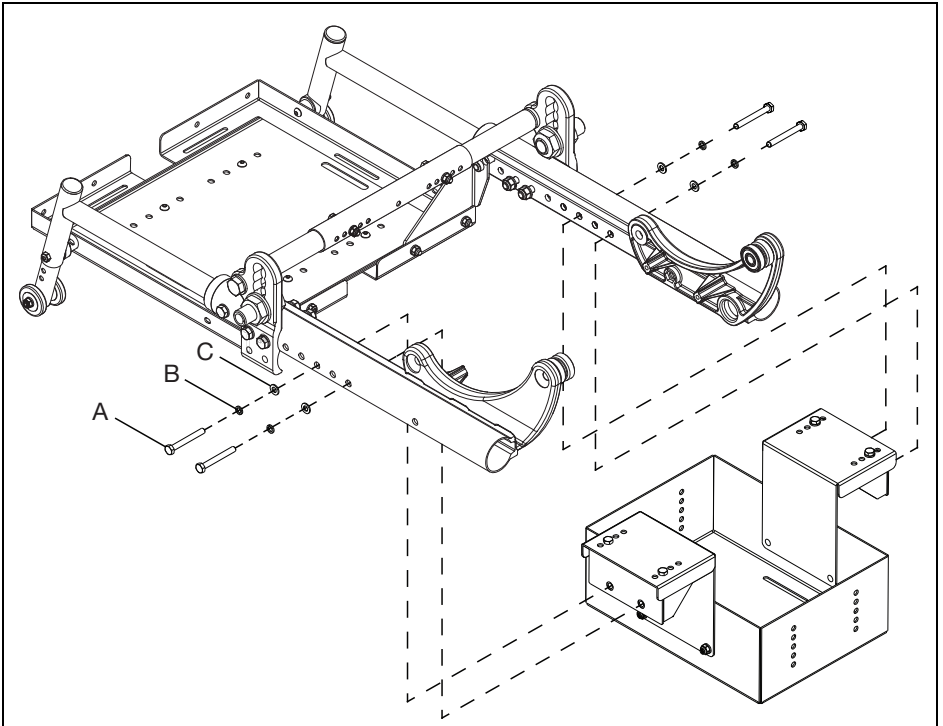

Vent and Battery Tray

9. Remove bolt and nut from bearing assembly using a 6mm Allen wrench and an 18mm wrench. Save all other hardware. Repeat on opposite side.

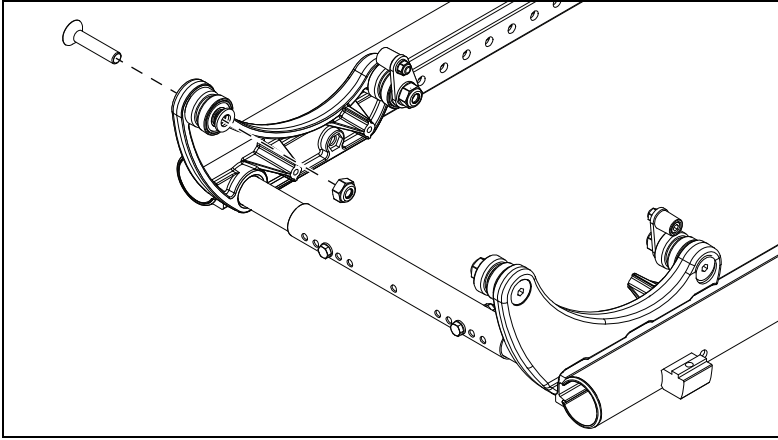

10. Install growth strut (F) and strut ends (C) into the bearing openings with two lock washers (B) and two bolts (A) using a 6mm Allen wrench and an 18mm wrench. Ensure bearings are in place during installation.

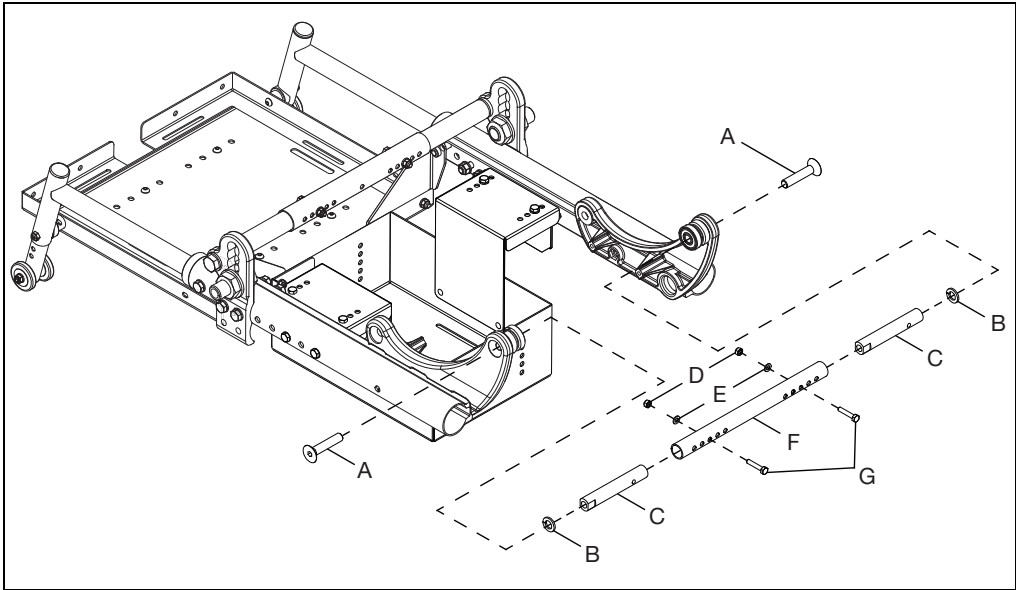

Power Tilt Installation

NOTE: Remove any seating / cushion on the chair along with the seat pan for access in later steps.

Removing Foot Tilt (If applicable)

1. Use two 13mm wrenches to remove the two bolts (A) and nuts (B) on the foot tilt pedal. Reinstall the axle plate (C) and anti-tip bracket (if applicable) (D) once the pedal is removed. New bolts have been provided for reinstalling the axle plate to prevent excess threads from hanging out, the longer option is for chairs with foot lock.
2. Detach drive rod by removing nut (E) using a 5.5mm wrench.
3. Remove tilt mechanism assembly by removing two bolts (F) and two washers (G), on each side, with a 10mm wrench.

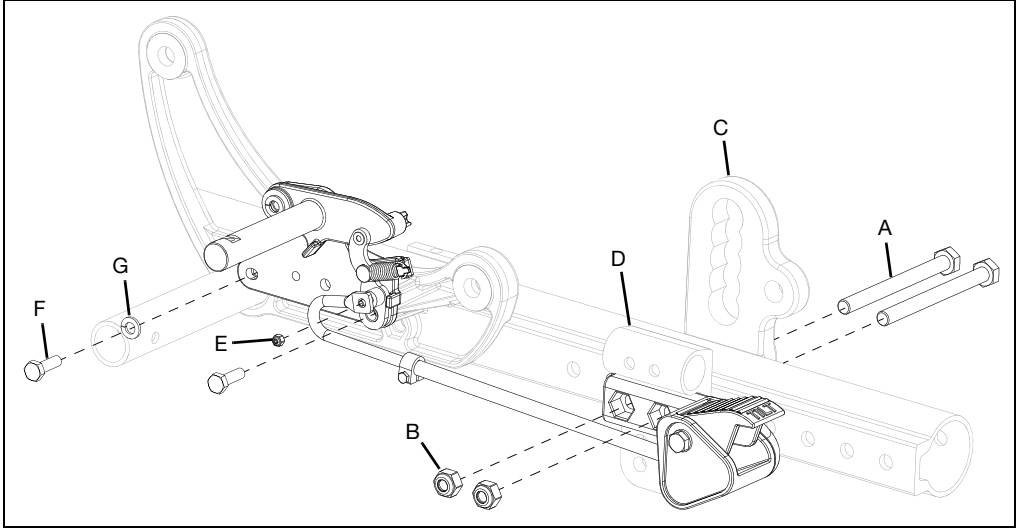

Removing Hand Tilt (If applicable)

1. With a tilt mechanism Revision 1, detach existing cable by removing bolt (A) with a 2.5mm Allen wrench. For a tilt mechanism Revision 2, detach existing cable by removing nut (B) and drive bushing (C) located on tilt mechanism with a 5.5mm wrench. For tilt mechanism Revision 3, detach existing cable by removing E-Clip (D). Remove cable from mount (E). For a horizontal tilt mechanism, the cable can remain attached.

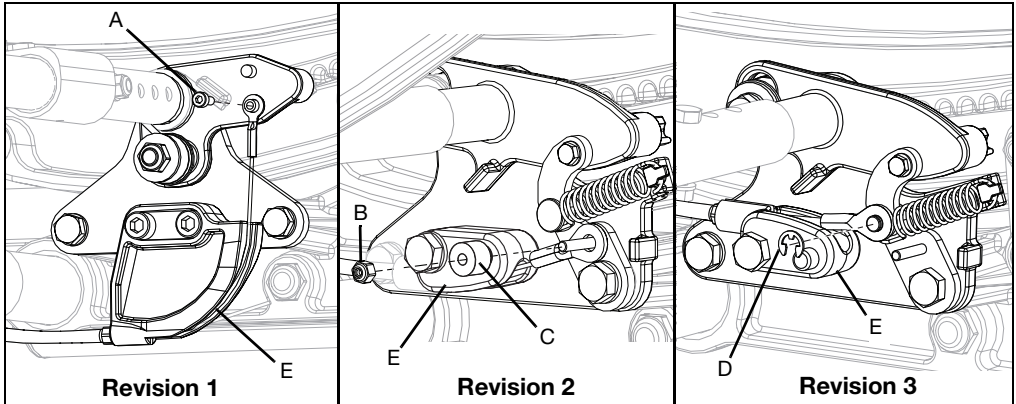

Power Tilt Installation

2. Use a 10mm wrench to remove P-Clip (A) securing cable, located by backrest mounting plate, by removing the nut (B) while keeping bolt in place. Once P-Clip is removed, reinstall nut.

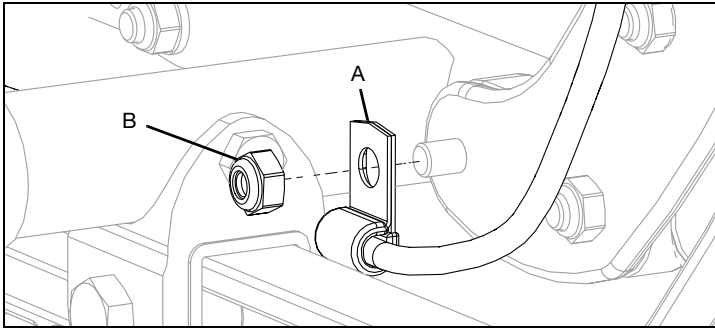

3. Remove cable clip(s) (A) on the back cane and finish cable removal by pulling cable out of the tilt lever (B).

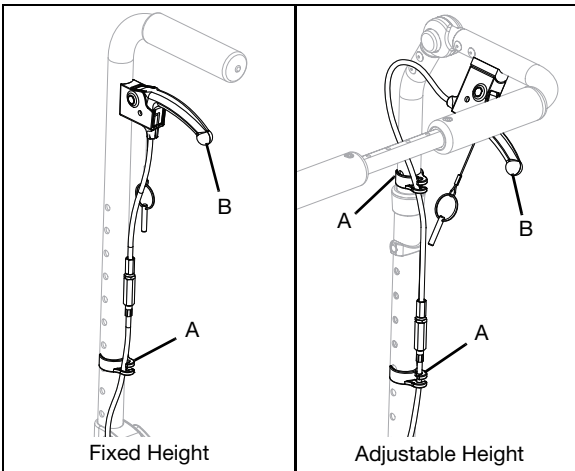

4. Remove tilt lever by lifting lever to access lever mounting screw. Remove lever by using a #2 Phillips screwdriver.
5. Remove tilt mechanism assembly by removing two bolts (A) and two washers, on each side, with a 10mm wrench. Repeat on opposite side.

NOTE: The horizontal tilt mechanism does not have washers to remove.

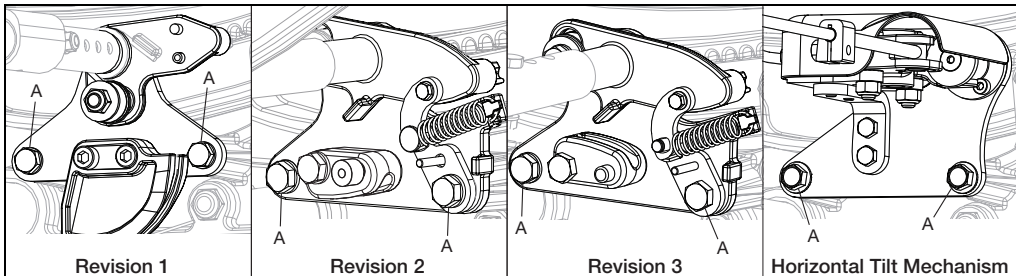

6. For a dual hand tilt, repeat the same steps on the opposite side.

Power Tilt Installation

NOTE: Unplug all cables from the battery before doing any work.

Removing Revision 1 Power Tilt

1. Remove power tilt rack assembly by removing four bolts (A), four washers (B) and four nuts (C) using two 10mm wrenches. Guide the front end of the power tilt rack assembly out of the gearbox to remove. Retain all hardware.

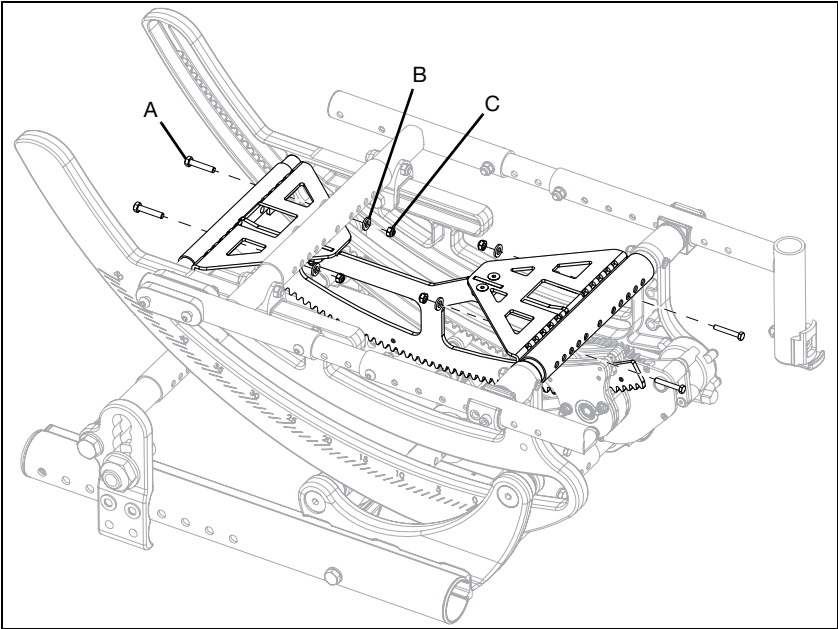

2. Remove two bolts (A), two washers (B) and two nuts (C) on the power tilt strut tubes using two 10mm wrenches. Retain all hardware.

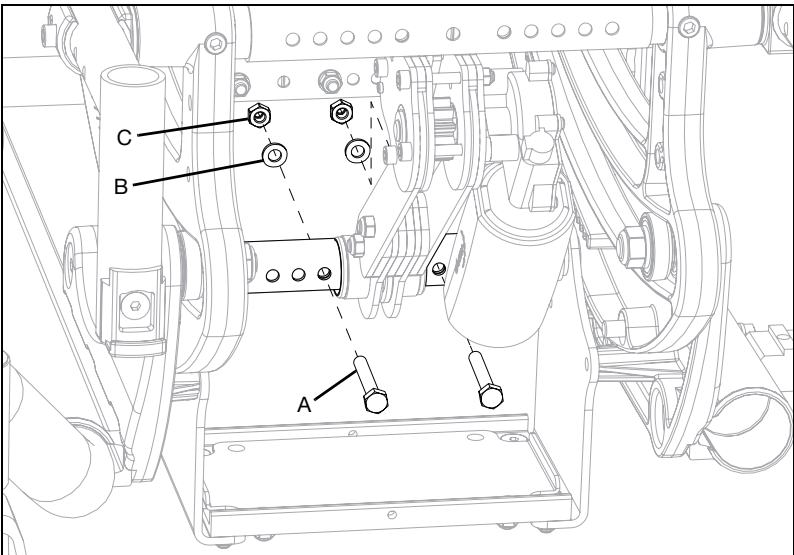

Power Tilt Installation

3. Remove battery tray / motor assembly by removing four bolts (A) and four lock washers (B) using a 10mm wrench. Retain all hardware.

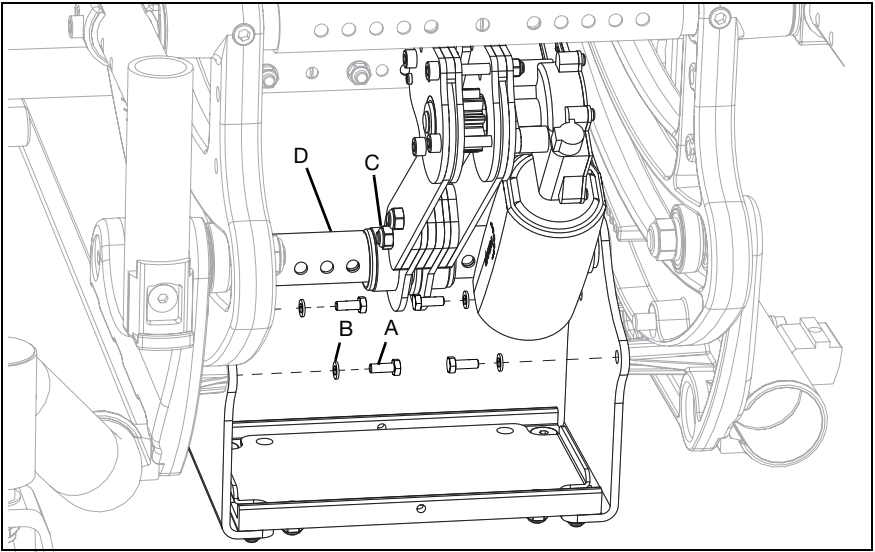

4. Remove the end of the motor arm (C) from the power tilt strut tube (D).

Installing Power Tilt

1. Install end of motor arm (A) onto the power tilt strut tube (B).
2. Install battery tray / motor assembly onto chair with four bolts (C) and four lock washers (D) using a 10mm wrench.

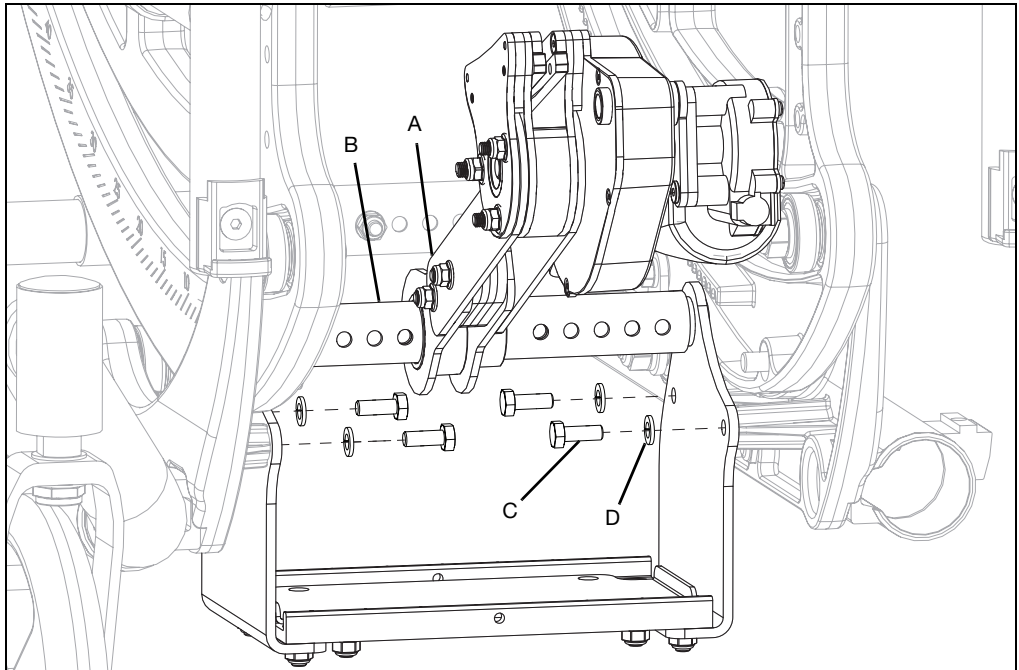

Power Tilt Installation

- Adjust power tilt strut tubes to fit and secure with two bolts (A), four washers (B) and two nuts (C) using two 10mm wrenches.

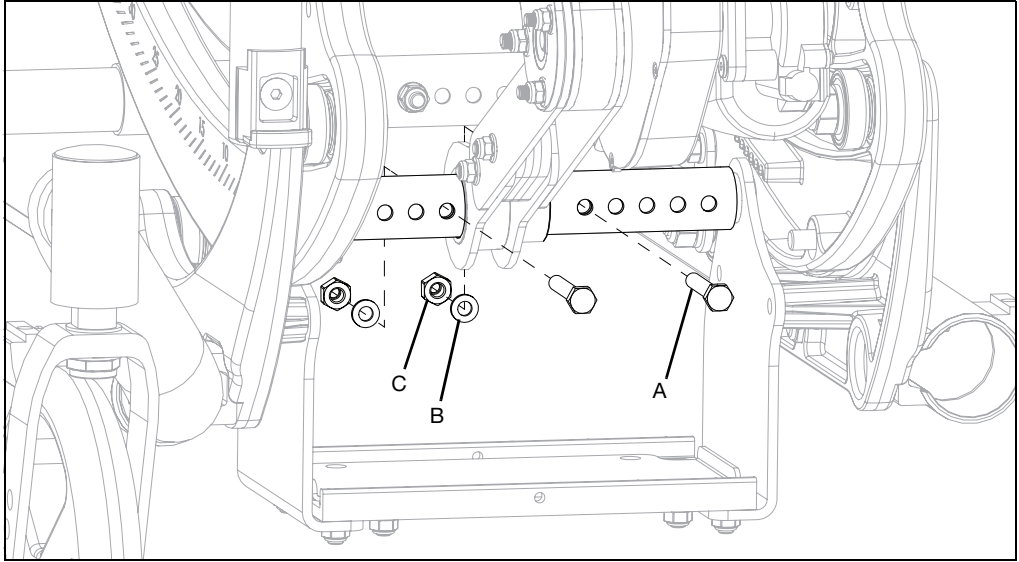

- Install battery (A) into battery tray. The side of the battery with six ports faces the rear of the chair. Secure battery by installing battery bracket (B) with two bolts (C) using an 8mm wrench.

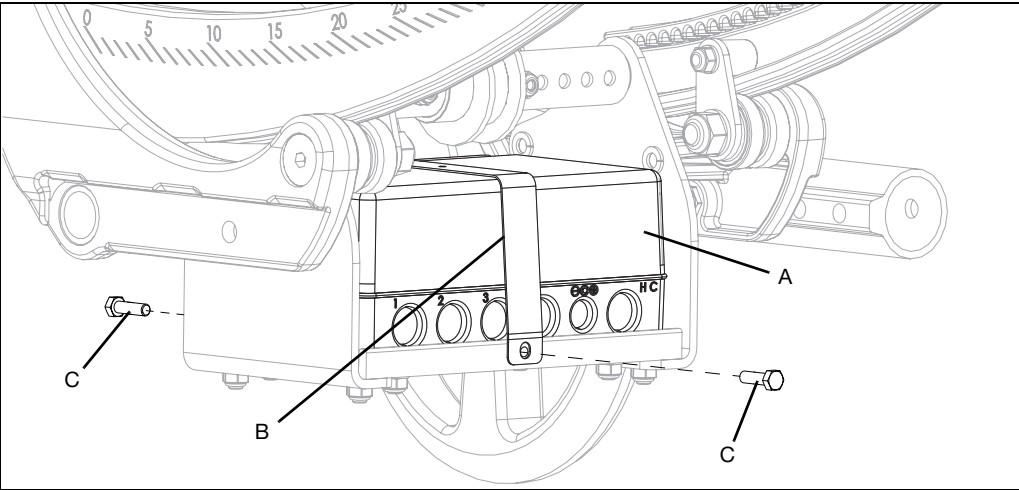

Power Tilt Installation

5. Mount power tilt rack (A) onto rack mounts (B) using four screws (C) and four nuts (D) with a 3mm Allen wrench and an 8mm wrench.

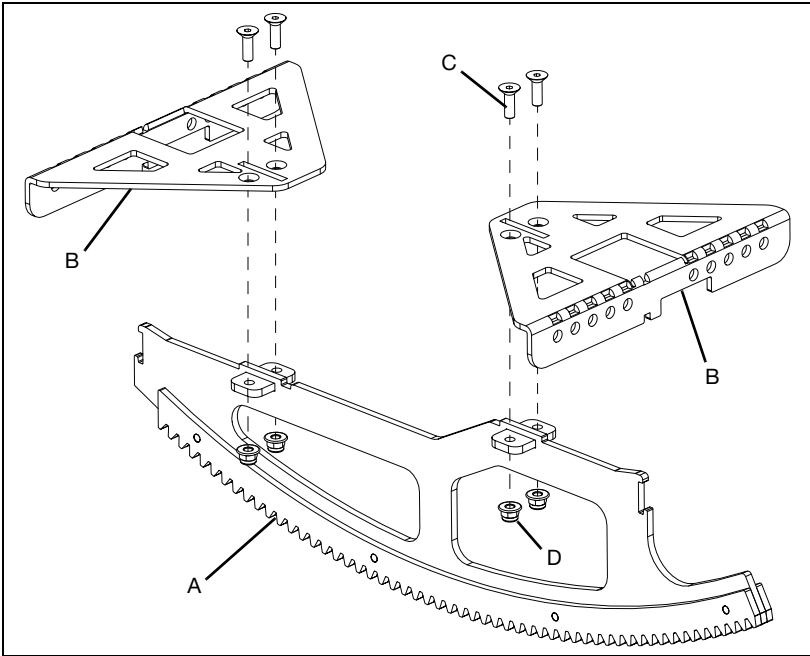

6. Pull the motor disconnect pin (A). Install power tilt rack assembly by guiding the front end into the gearbox (B). Secure the power tilt rack assembly by installing four bolts (C), four washers (D) and four nuts (E) using two 10mm wrenches. Reconnect motor disconnect pin.

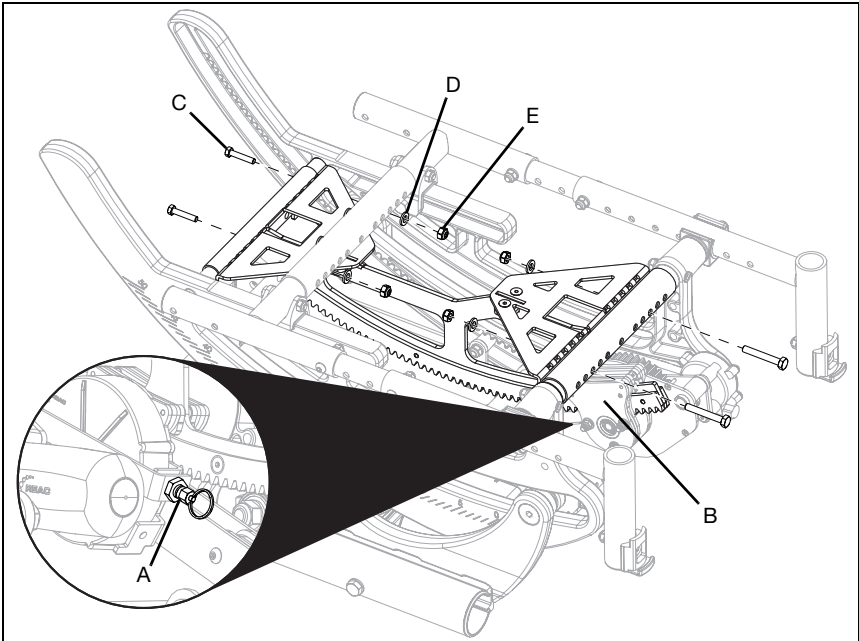

Power Tilt Installation

7. Install mount block (A) onto hand control toggle switch (B) with two bolts (C) and two lock washers (D) using a 10mm wrench. Finish installing hand control toggle switch onto the armrest tube with a bolt (E) that passes through lock washer (F), band clamp strap (G), band clamp mandrels (H), clamp spacer (I), control switch spacer (J) and into the mount block using a 10mm wrench.

NOTE: New revision of the mount block and control switch spacer also allow the toggle control switch to be mounted in the vertical position.

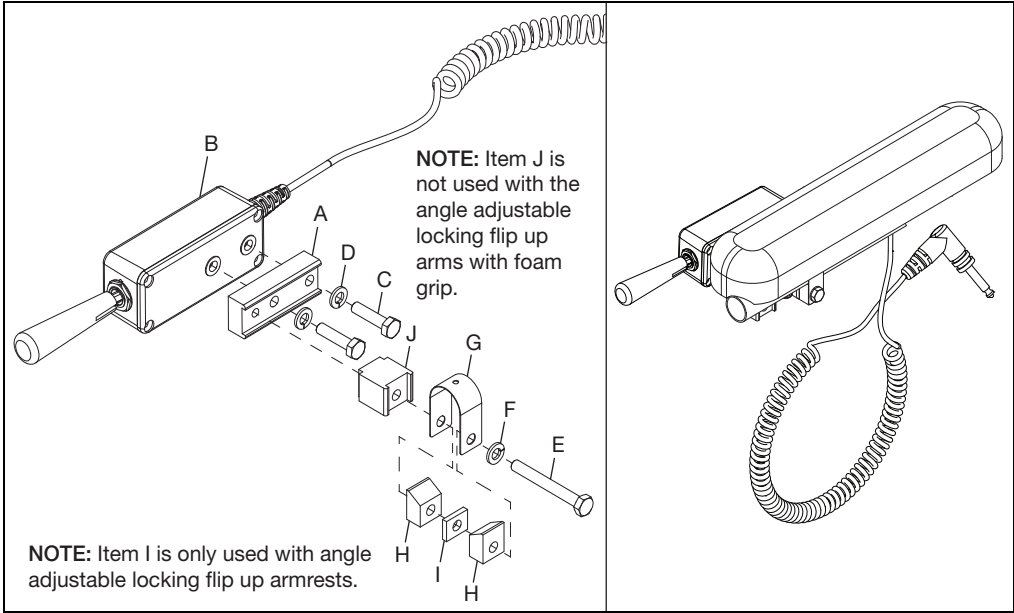

8. Install extension cable mount (A) onto base frame tube bracket (B) with two bolts (C) and two nuts (D) using a 3mm Allen wrench and a 7mm wrench. Install the extension cable mount assembly onto the base frame tube with a bolt (E), two washers (F) and a nut (G) using two 13mm wrenches. Install the extension cable (H) onto the extension cable mount assembly and secure with two bolts (I) and two nuts (J) using a 3mm Allen wrench and a 7mm wrench.

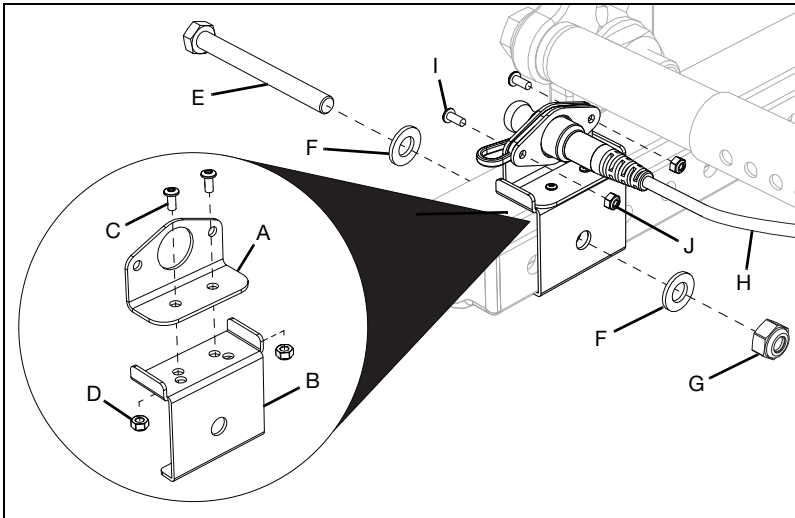

Power Tilt Installation

9. Connect the cables to the battery as shown below.

NOTE: Ensure that all cables are not wrapped, tangled or in any way restrictive within the full range of the tilt of the chair.

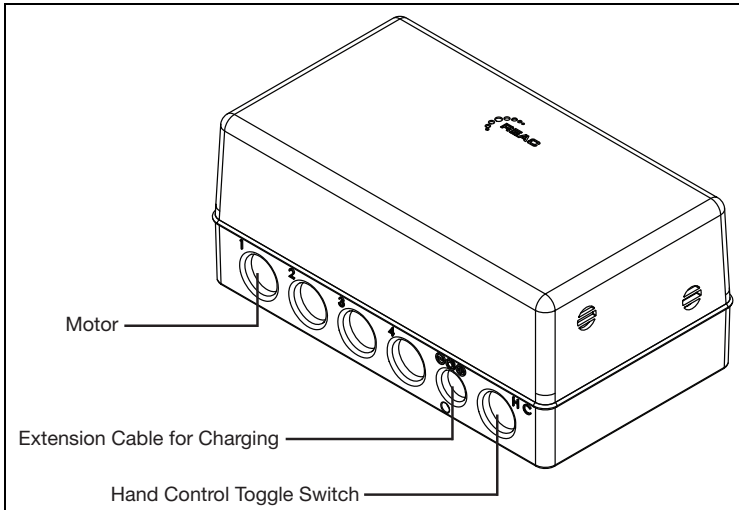

10. Test the power tilt, ensuring it tilts and returns without issue.

NOTE: The chair user will need to go through a center of gravity adjustment before use. It is also recommended that the chair user charges the battery before first use.

Installing Tilt Stops

NOTE: Tilt stops are to be installed to prevent anterior tilt.

NOTE: Curved side of the tilt stop pads must be installed so they are the contact point for the stop.

1. Install tilt stops on the front end of the rotary frame to prevent anterior tilt. The bolt (A) passes through the washer (B), thrust plate (C) and tilt stop pad (D) on the outer side of rotary frame and through the tilt stop pad (D), thrust plate (C), washer (B) and nut (E) on the inner side using two 10mm wrenches. Repeat steps to install tilt stops on the back end of the rotary frame to prevent posterior tilt.

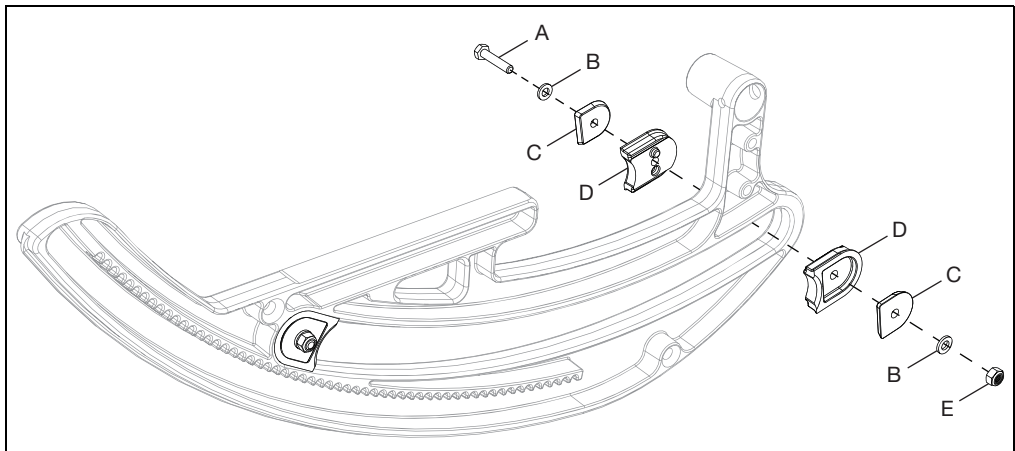

Power Tilt Motor Replacement

NOTE: It is recommended to remove a seat pan, if the chair uses one, for easier access to parts.

NOTE: For best access, tilt the chair so the rear is on the floor and the front is in the air. Ensure chair is in a stable position and be careful not to scratch paint. Drawing views will be shown in this orientation.

Power Tilt Motor Removal

1. Disconnect all cables associated with the power tilt unit and battery.
2. Remove two bolts (D) and nuts (A) from motor assembly arm (B) using a 4mm Allen wrench and an 8mm wrench (Some configurations may require two 8mm wrenches for removal). When the bolts and nuts are removed, be careful of any tilt movement that may occur with the rotary frame. Also, four spacers (C) will drop out which should be saved for later use.

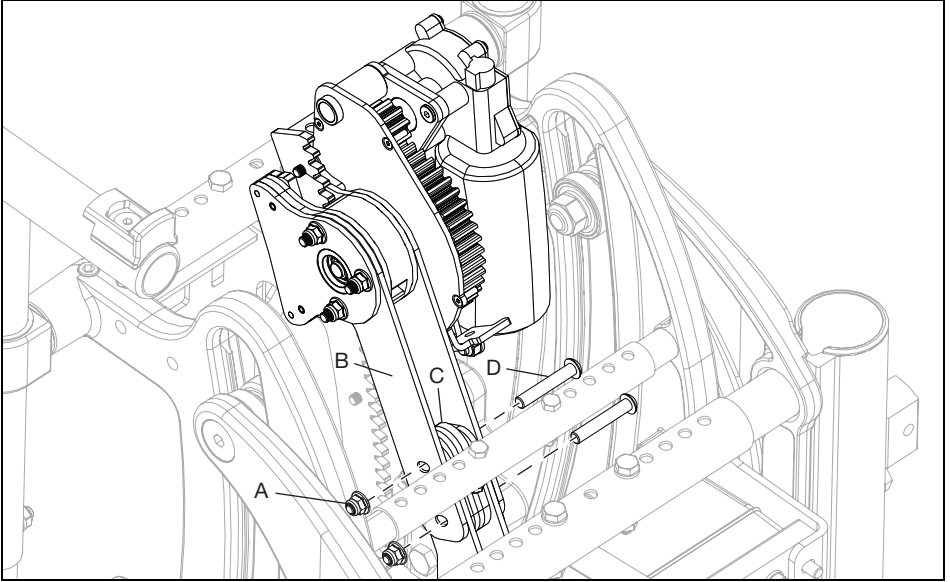

3. Pull motor pin (A) and pull down to other pin hole. Release motor pin so pin aligns in the hole.

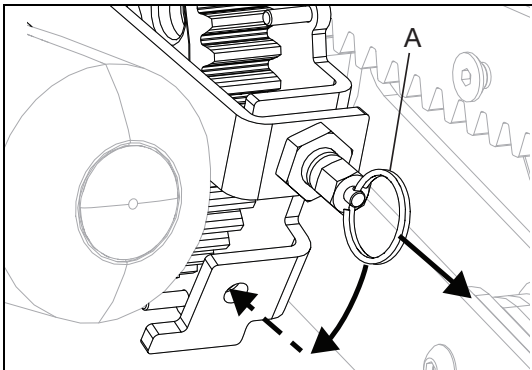

Power Tilt Motor Replacement

4. Slide motor assembly off the power tilt rack.

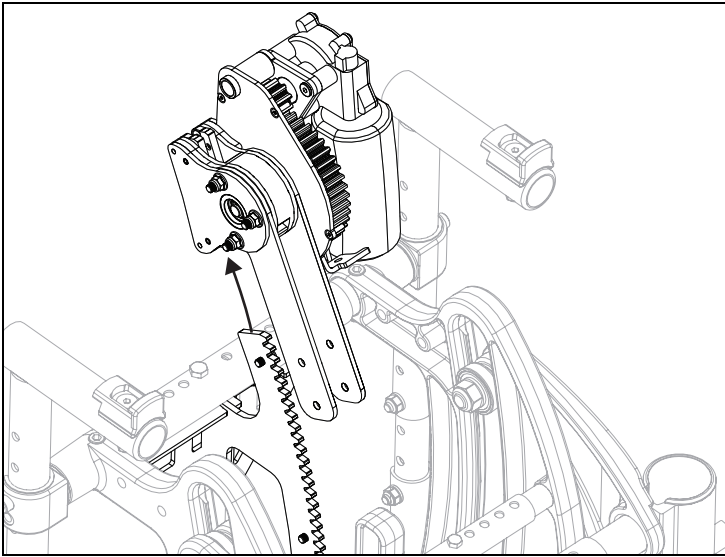

Installing New Motor Assembly

1. Slide new motor assembly onto power tilt rack. Check to see if the pin is in unlocked position if the assembly doesn't slide on. Lock the pin once in position.

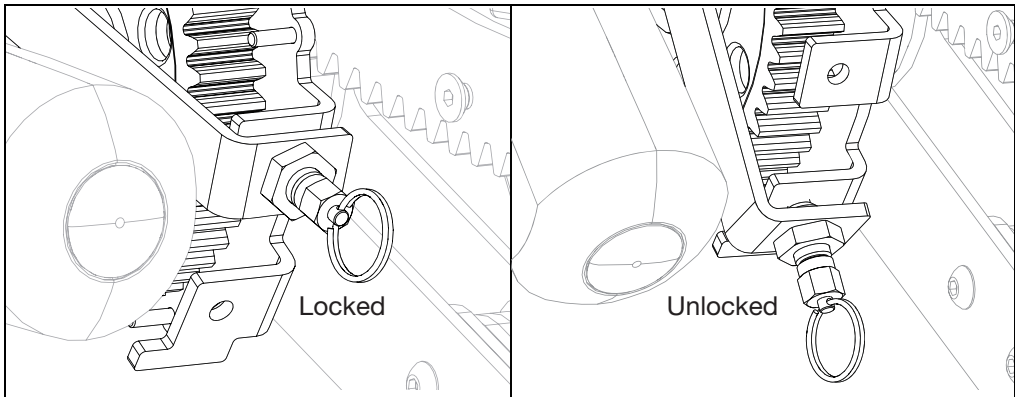

Power Tilt Motor Replacement

2. Connect the two sides of the motor assembly arms with four spacers (B), two bolts (C) and two nuts (A). The motor assembly can be moved up or down on the power tilt rack until the holes align. Once they do, put the pin into locked position to prevent unintended movement while installing hardware.

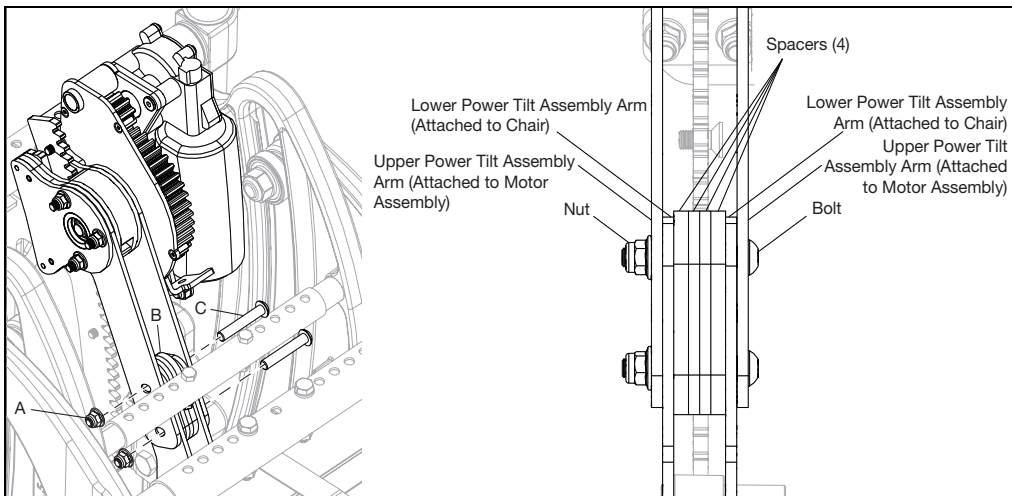

Test Power Tilt Function

1. Reattach the power tilt and battery cables.

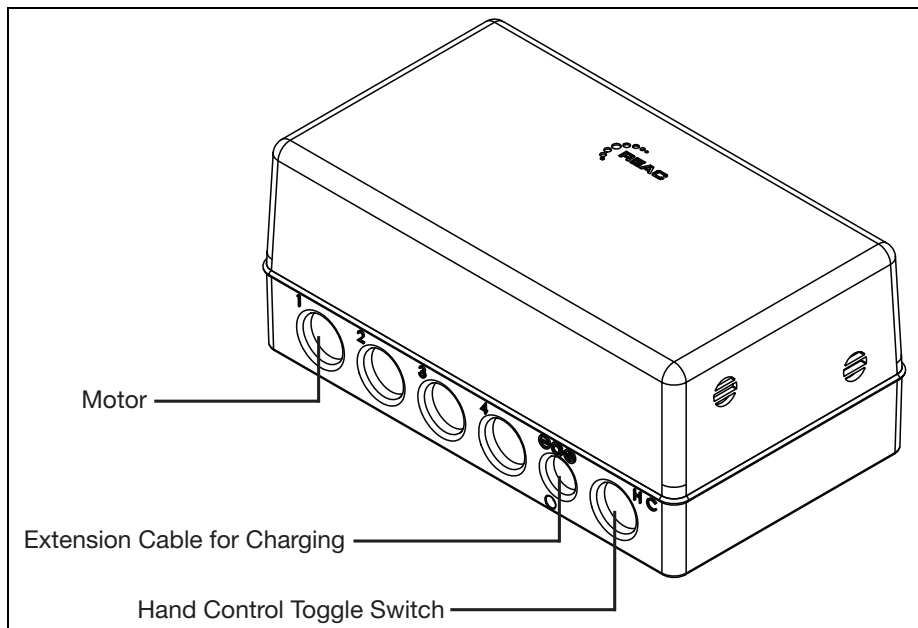

2. Without a user in the chair, test the chair to ensure power tilt goes through the tilt range.
3. With power tilt function verified, reinstall any items that may have been removed prior to starting the motor replacement procedures (seat pans, cushions, etc.).

Power Tilt Interface Control Box - Installation and Use

The Focus Power Tilt uses a Reac RCB10 battery and interface control box when operating with adaptive switches. The Reac Control Box - RCB10 is a compact and flexible 4 channel control box with a 2 Ah battery pack and an external charger. The RCB10 is designed to comply with standards for powered wheelchairs (EN 12184:2014) and assistive products (EN 12182:2012).

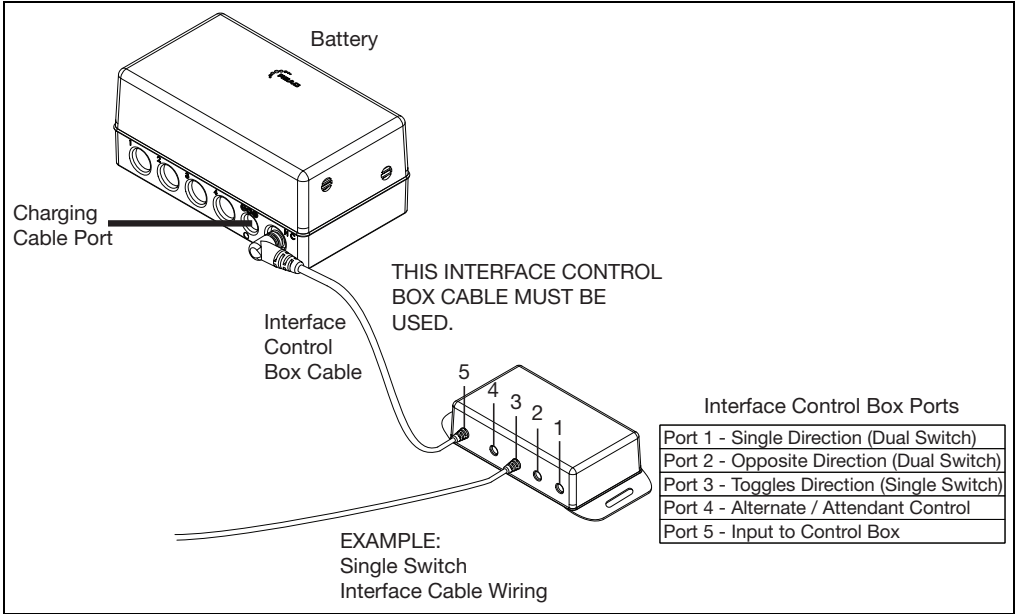

Interface Control Box Mounting

Mount the interface control box and cable in a location that the cable will not be pinched, cut, trapped by moving components or obstruct tilt movement. The interface control box must be close enough to the battery so that the cable is not stretched or pulled free. Ensure cable is not exposed to being caught or snagged by any other objects.

Connecting Adaptive Switches to Interface Control Box (See image above)

For a single switch, connect the single switch interface cable to port three on the interface control box. For a dual switch, connect the two dual switch interface cables to port one and two of the interface box. Route the adaptive switch cable(s) so it will not be pinched, cut, trapped by moving components or obstruct tilt movement. Ensure there is enough slack in the cable(s) so they are not stretched or pulled free from the interface control box or mounting location.

NOTE: The interface control box cable accepts a 3.5mm / 1/8" mono phono jack.



WARNING



WARNING: Ensure hand control box and cables are secure and out of the way of any moving parts to prevent possible damage and/or a possible fall which can result in injury or death.

Power Tilt Interface Control Box - Installation and Use

Initial Charge

1. Identify the box with the charger.
2. Connect the charger cable to the extension cable (A).
3. Plug the other end of the charger into a wall outlet for an initial charge.
4. Fully charge battery before first use.

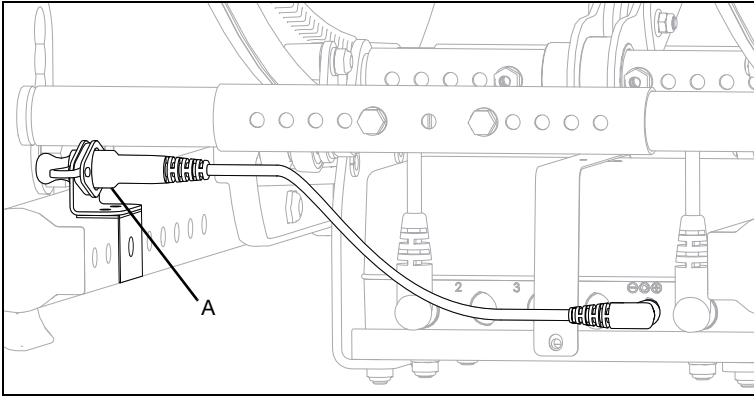

Charging

For more information on charging and the battery charger, refer to the battery charger owner's manual that is included in the battery charger box.

- The battery is charged through the external charger.
- Charging is only allowed with charger provided.
- Charging time for a completely discharged system is approximately 6 hours.
- Charging must take place in a room with good air ventilation and a temperature of 0-40°C (32-104°F).
- Operation is prevented by the system during charging.
- If stored, the battery must be charged before use.

Center of Gravity Adjustment

NOTE: A Center of Gravity adjustment is required for initial use and after any adjustment is made to the chair.

1. With the occupant in the chair, ensure two people are present to assist in the Center of Gravity adjustment.
2. One person must support the back of the chair to prevent a sudden drop while the other person assisting pulls the motor disconnect pin (A) on the power tilt assembly.

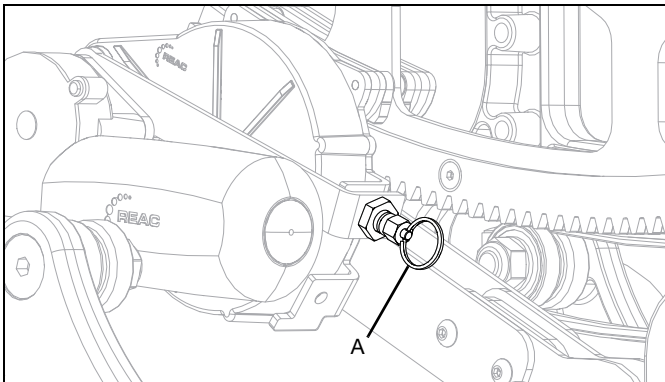

Power Tilt Interface Control Box - Installation and Use

3. Allow the chair to settle into position and read the angle measurement on the rotary frame.

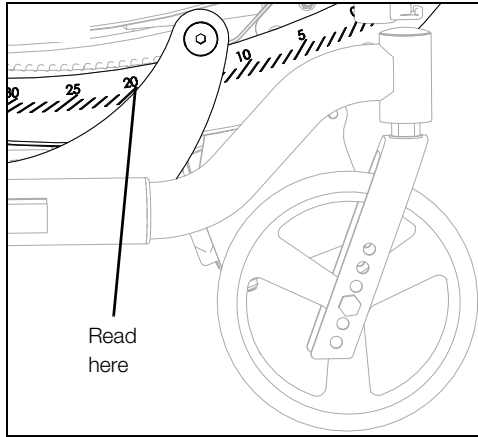

4. The chair should settle around 20°, if not, the seat frame set up needs adjustment. See the Seat Frame Set Up section in your owner's manual.
5. If the chair does settle around 20°, reinsert the motor disconnect pin.

⚠ WARNING ⚠

WARNING: Ensure the motor disconnect pin is fully engaged before attempting a transfer. Failure to comply with the instruction above could result in serious injury or death.

Toggle Switch Hand Control Use

1. Ensure hand control toggle switch and the motor are connected to the battery before use. See image below.

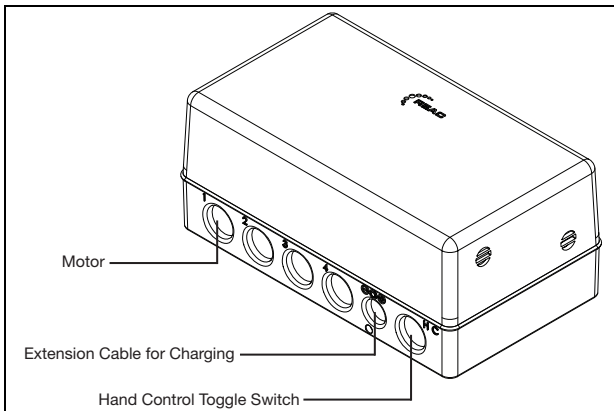

Power Tilt Interface Control Box - Installation and Use

2. Pulling the hand control toggle switch up will tilt the chair.
3. Pushing the hand control toggle switch down will undo the tilt.

NOTE: The power tilt motor has limits set to protect the system if too much energy is required to change the tilt angle. If a limit is triggered, the motor will reset to an active state within a few seconds. These same limits are responsible for the motor discontinuing when the rotary frame reaches the maximum tilt range or a tilt stop. Power tilt chairs with recline are more susceptible to a motor reaching a limit and discontinuing when the client is reclined because the center of gravity has changed. It may be necessary to reduce the recline angle of the client for the motor to operate normally.

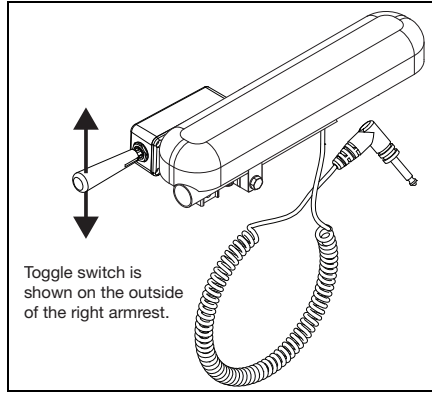

Rotating Toggle Switch Hand Control

1. Loosen bolt holding clamp and hardware to the toggle switch until the toggle control can be detached using a 10mm wrench.
2. Rotate the toggle switch 90° so toggle switch is perpendicular with the armrest.
3. Reinstall the toggle switch onto the clamp hardware assembly and secure by tightening bolt with a 10mm wrench.
4. Now, pulling the hand control toggle switch back will tilt the chair and pushing the switch forward will undo the tilt.

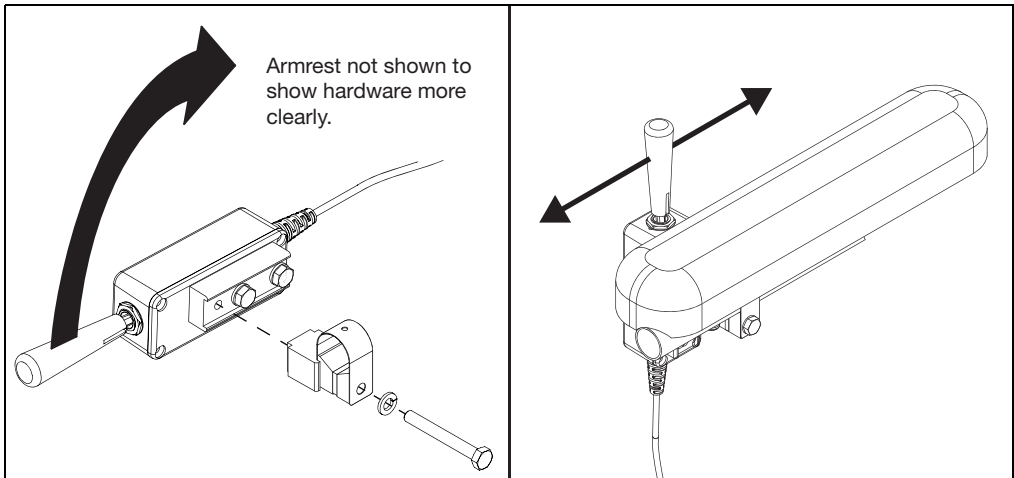

Power Tilt Interface Control Box - Installation and Use

Pendant Hand Control Use

1. Ensure hand control toggle switch and the motor are connected to the battery before use. See image below.

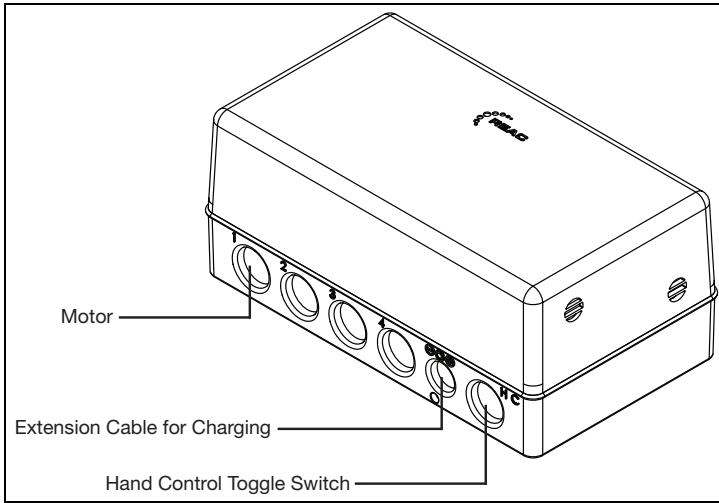

2. Push the down arrow button to tilt the chair.
3. Push the up arrow button to undo the tilt.
4. Push the power button to turn on or turn off the battery level lights.
5. Push and hold the up and down arrow buttons for three seconds to lock the key functions. Repeat to unlock key functions.

NOTE: The pendant hand control has a hook at the end of the control. This hook can be used to mount, or hang, the control on the wheelchair. Wherever the hand control is mounted, ensure cable is not in a position where it will be pinched, cut, trapped by moving components or obstruct tilt movement.

NOTE: The power tilt motor has limits set to protect the system if too much energy is required to change the tilt angle. If a limit is triggered, the motor will reset to an active state within a few seconds. These same limits are responsible for the motor discontinuing when the rotary frame reaches the maximum tilt range or a tilt stop. Power tilt chairs with recline are more susceptible to a motor reaching a limit and discontinuing when the client is reclined because the center of gravity has changed. It may be necessary to reduce the recline angle of the client for the motor to operate normally.

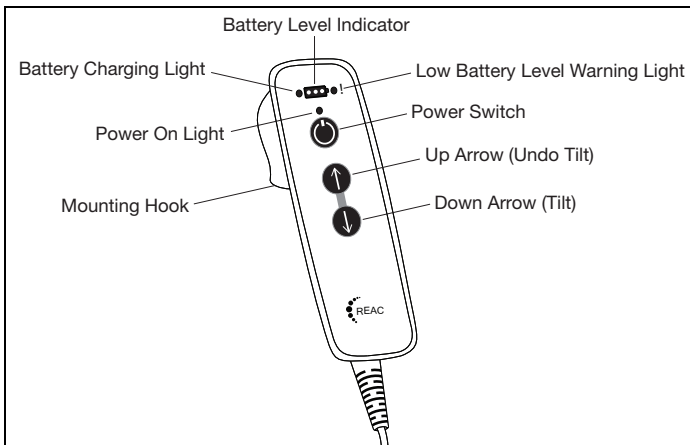

Power Tilt Interface Control Box - Installation and Use

WARNING

WARNING: In the unlikely event of battery acid leakage and you get acid in your eyes or skin - rinse thoroughly with water and contact your local healthcare professional for further consultation.

WARNING

WARNING: CHOKING HAZARD - The system is equipped with a charger connector plug to seal the connector hole, be aware that this plug can be removed and swallowed by a small child.

Transfers

WARNING

WARNING: Avoid the switch system and other adaptive switches when transferring to prevent unintentional chair tilting. Failure to comply with the instruction above could result in serious injury or death.

Cleaning and Disinfection

The RCS system is designed to fulfill IPx4 (or IPx6 as an option), which allows cleaning with water. For disinfection, it is recommended to use soap or equal and clean with a paper towel/rag.

Standard Features
Controls: 1-4 channel individual actuators
Current Limit Control: Default 8 A
System Power: 24VDC
Batteries: <ul style="list-style-type: none">•2 Ah (sealed lead accumulators)•Ventilated housing
Charger: Power supply 120 VAC - 230 VAC
Protection Class: IPX4
Color: Black and orange
Weight: 1.9 kg (4.19 lbs) (including batteries)
EMC Conformity: <ul style="list-style-type: none">•EN 61000-6-2•EN 61000-6-3•EN 60601-1-2•ISO 7176-21
Operating Temperature: -15°C to +50°C (5°F to 122°F)
Storage Temperature: -40°C to +60°C (-40°F to 140°F)
Soft Start / Stop
Flammability Rating: UL94V-0
Single Fault Protection

Contracture Footrest

Installation

1. Install foot pivot (B) into footplate clamp (C). Install footplate (E) onto footplate clamp (C) with two screws (A) and two nuts (D) using a 5mm Allen wrench and a 10mm wrench.

NOTE: There are three sets of holes that the footplate can be mounted with. The holes allow for the footplate to be mounted further forward or further backward, depending on the configuration desired by the user.

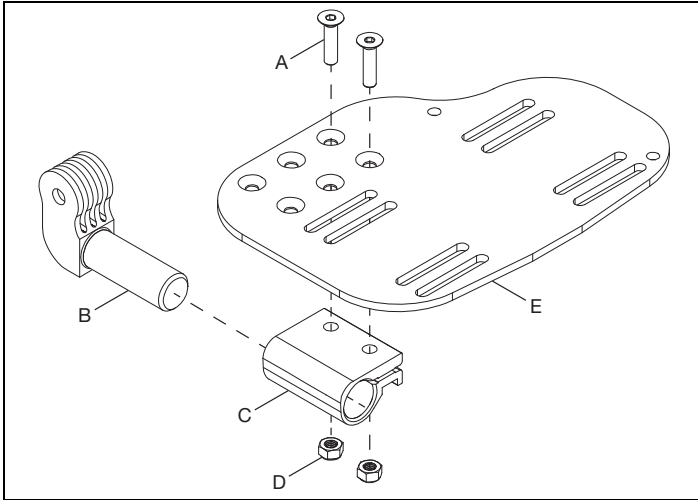

2. Install short pivot (D) into footplate assembly with a screw (E) and nut (F) using a 5mm Allen wrench and a 13mm wrench. Install extension tube (A) onto short pivot (D) using a screw (C) and nut (B) using a 5mm Allen wrench and a 10mm wrench.

NOTE: Tighten the pivot joint screw (E) to 240 in/lbs.

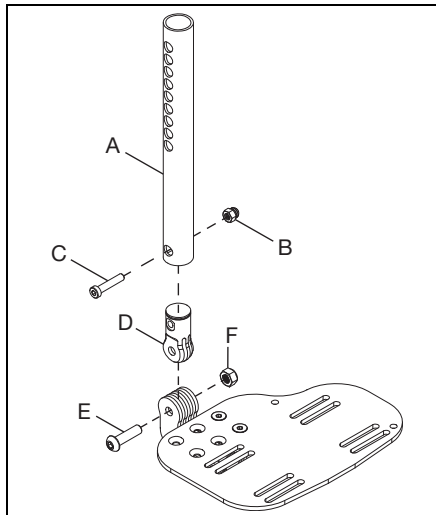

Contracture Footrest

3. Install long pivot (A) into extension tube. Use the chart below to determine the holes you will be using for the desired footrest height and secure in position by installing screw (B) and nut (C) using a 5mm Allen wrench and a 10mm wrench.

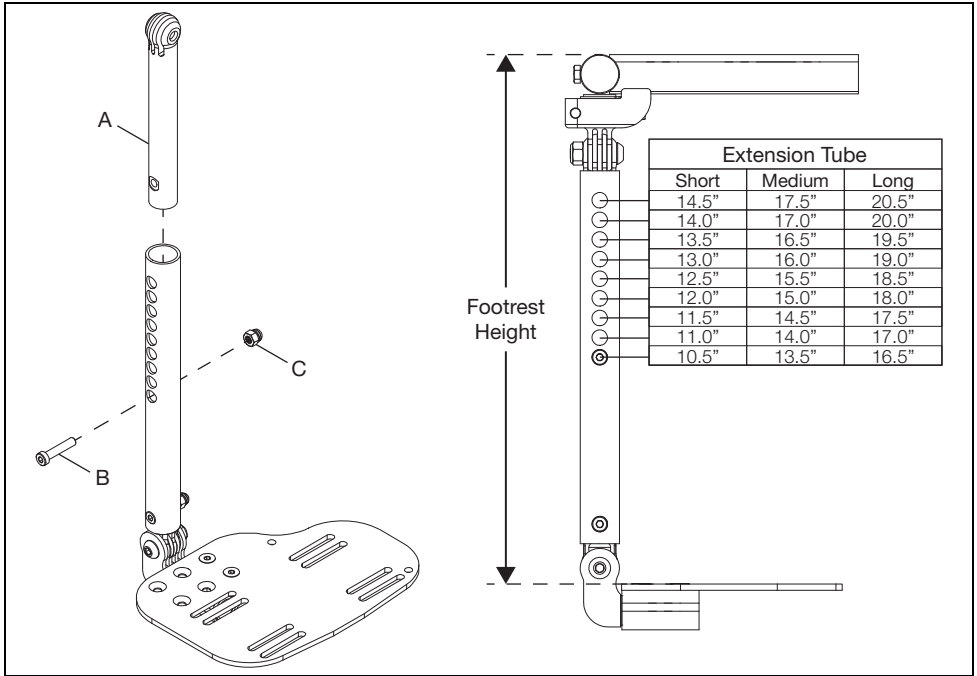

4. Install short pivot (E) into the long pivot and secure with screw (F) and nut (D) using a 5mm Allen wrench and a 13mm wrench. Install the slide mount (C) onto the short pivot (E) and secure by installing screw (B) with a 5mm Allen wrench and installing the retaining ring (A).

NOTE: Tighten the pivot joint screw (F) to 240 in/lbs.

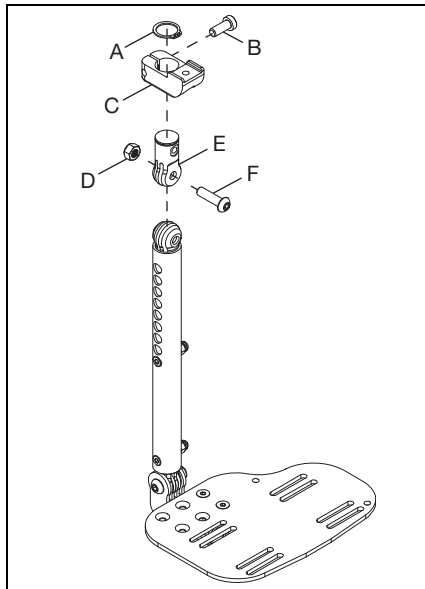

Contracture Footrest

5. Remove any seating system, cushion, seat pan and/or hangers from the chair.
6. Remove strut tube (C) from seat frame by removing two screws (A) and two nuts (B) with a 4mm Allen wrench and a 10mm wrench. Save all parts.

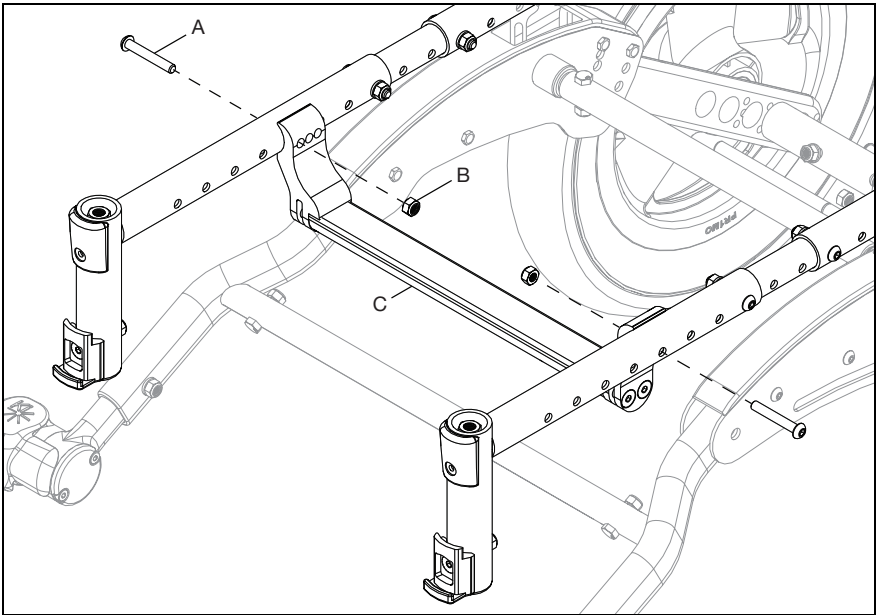

7. Remove front seat tube from chair by removing two screws (A), two washers (B) and two nuts (C) using a 4mm Allen wrench and a 10mm wrench.

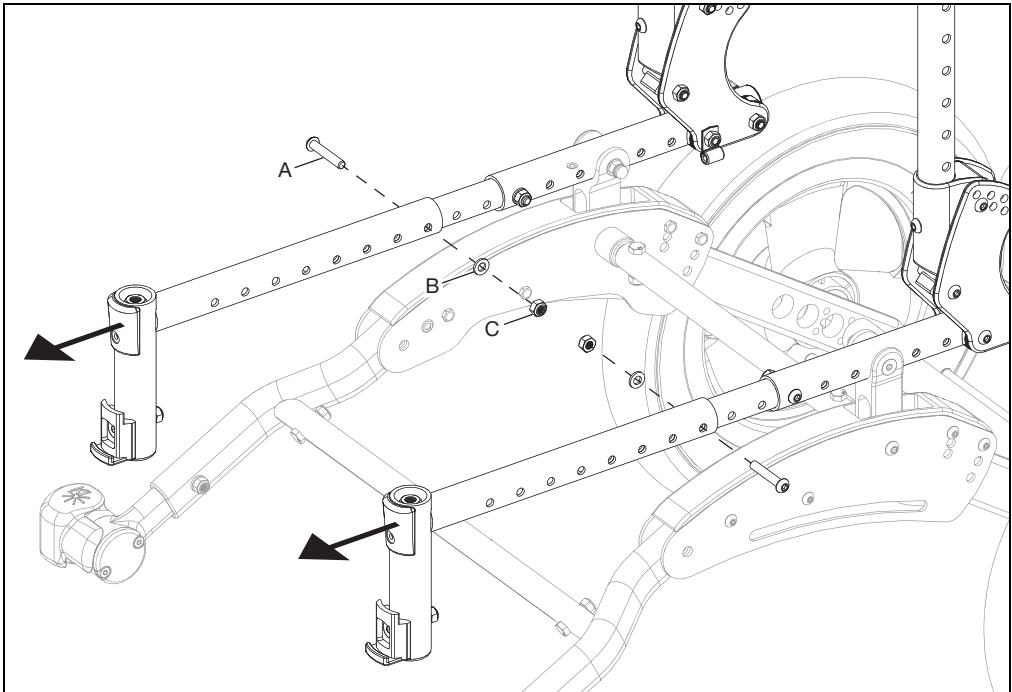

Contracture Footrest

8. Determine whether the contracture footrest is going to be set up in the outside mount or inside mount position. Install footrest assembly, outside or inside mounted, by sliding the contracture seat tube (C) onto the frame. Assemble footrest to contracture seat tube by installing T-Nut (D) along channel on the inside of the mount rail (E). Secure pieces in place by installing screw (A) through seat tube into the mount rail using a 10mm wrench and a screw (F) through the sliding mount into the bottom of the T-Nut using a 10mm wrench. Last, install end cap (B) into seat tube. Repeat on opposite side.

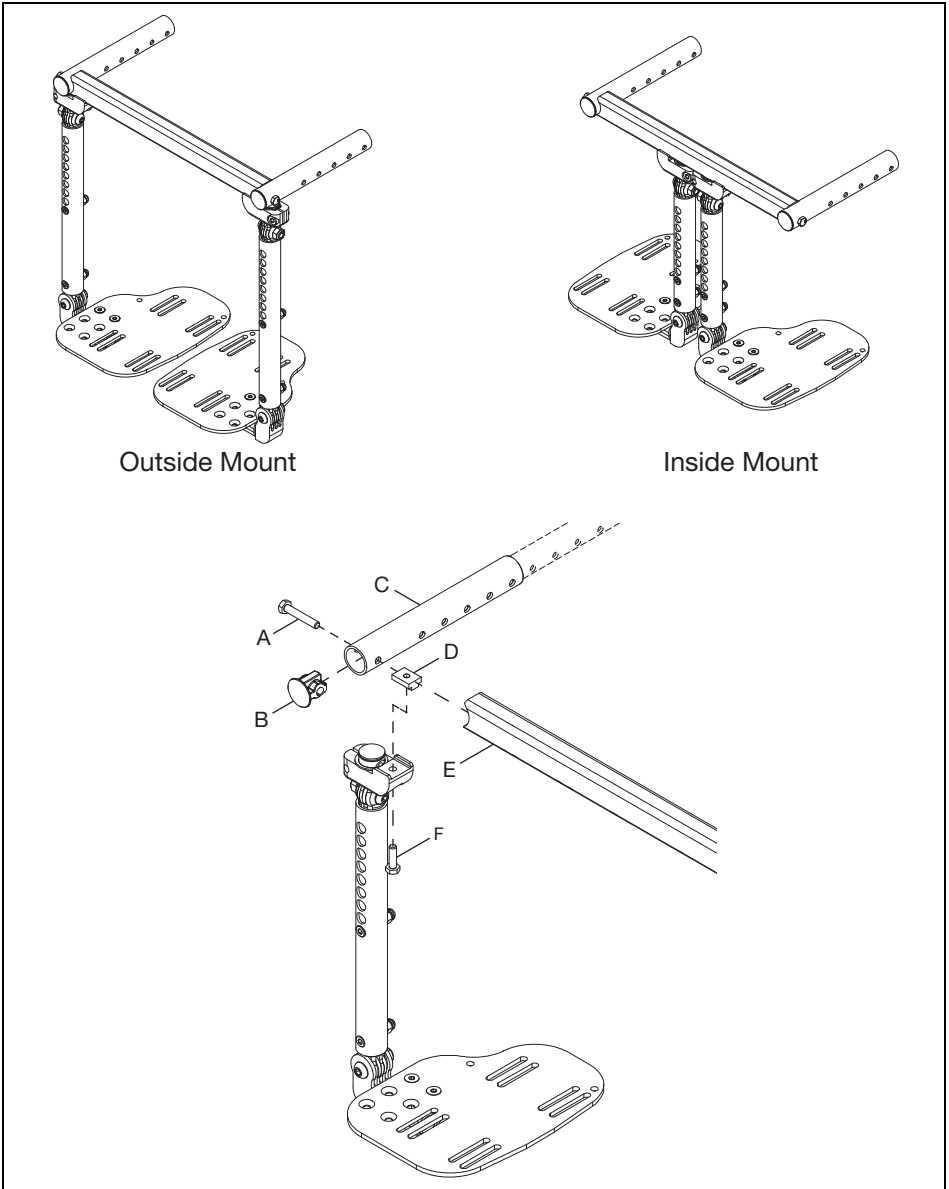

9. Reinstall strut tube, in the same position as before, and any seating system, seat pan or cushion that may have been removed before the installation process.

NOTE: See Step 6 for strut tube hardware and tools if needed.

Multi-Angle Footrest

Installation

1. Determine which configuration the ball shaft (D) will need to be in - down (eversion) or up (inversion). See figure below for example. Install footplate (B) onto upper footrest clamp (C) with two screws (A) using a 4mm Allen wrench. Install ball shaft (D) into lower footrest clamp (E) and secure to the upper footrest clamp using three screws (G) and three lock washers (F) using a 5mm Allen wrench.

NOTE: Install the footplate to the upper footrest clamp using the set of holes needed for the desired configuration. The holes allow the footplate to be moved further inward or outward depending on preference.

NOTE: Torque the three screws (G) to 144 in/lbs.

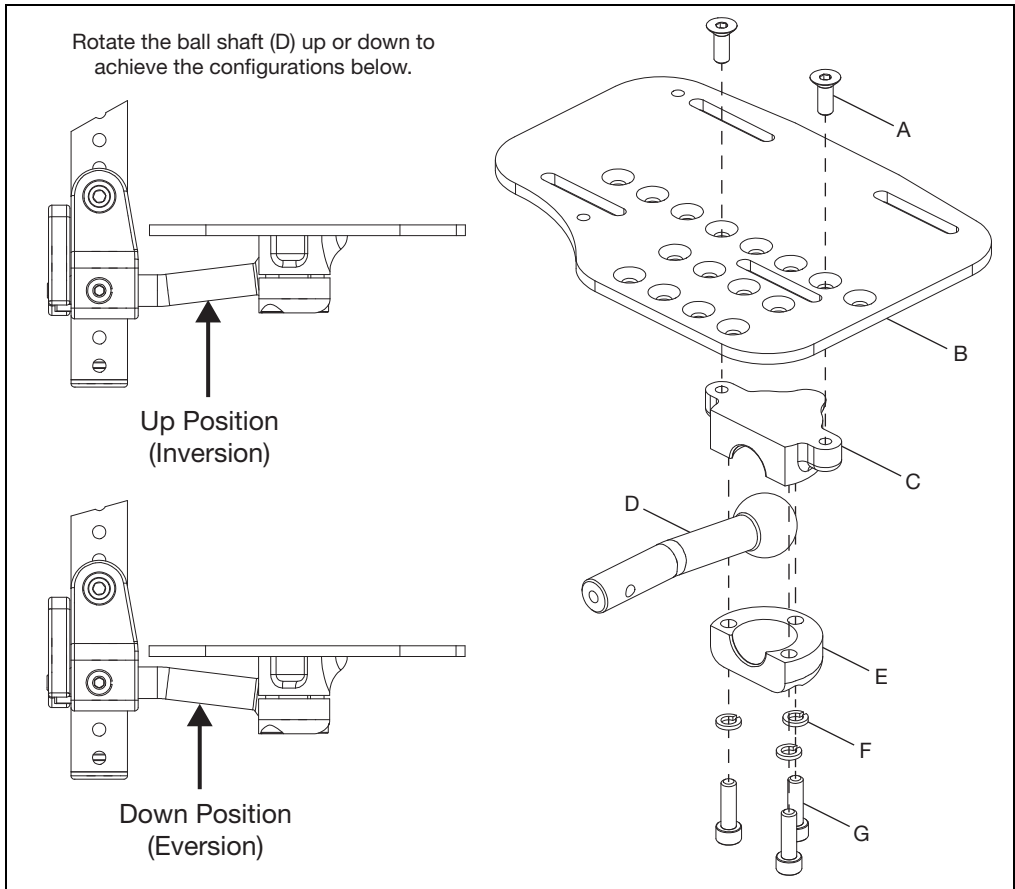

Multi-Angle Footrest

2. Install footrest mount (E) onto the end of the ball shaft and secure with screw (H) and lock washer (G) using a 4mm Allen wrench. Install the flip-up latch (D) onto the footrest mount and secure with latch spring (C), bushing (B) and screw (A) using a 4mm Allen wrench. Push spring pin (F) into the footrest mount to limit the movement of the flip-up latch.

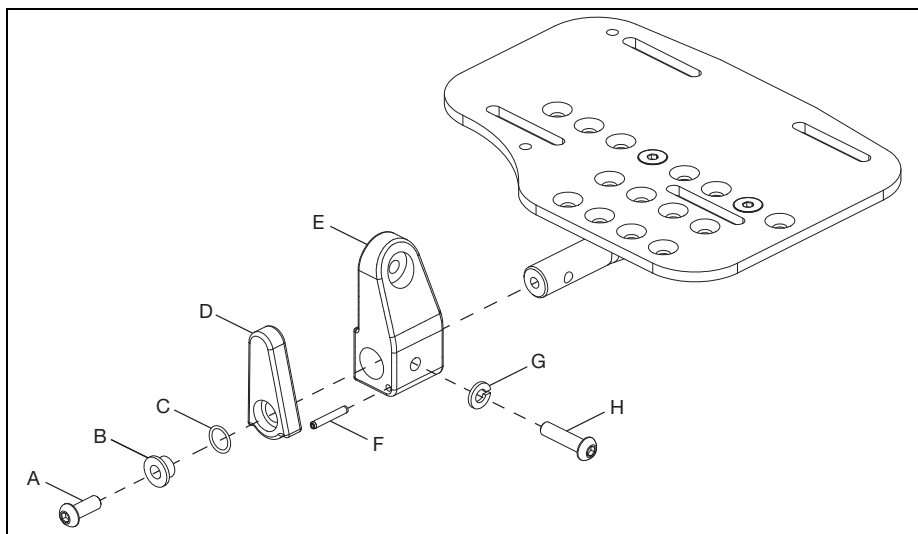

3. Install footplate assembly to hanger with screw (G), washer (Fig. 3:F), washer (E), saddle spacer (D), washer (C), washer (B) and nut (A) using a 5mm Allen wrench and a 10mm wrench.

NOTE: Install footplate assembly to hanger using the correct holes for the desired footrest height.

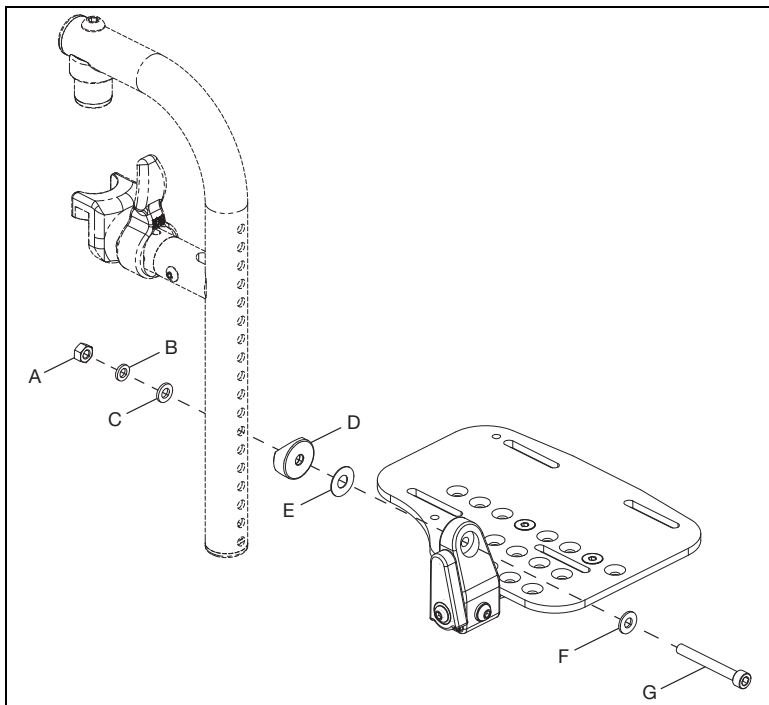

Pediatric Pro ELR

Installing Pediatric Pro Elevated Leg Rest Assembly

1. Remove current hangers from chair if applicable. Install latch blocks (A) if not present.
2. Install the Pediatric Pro ELR the same way as a swing away hanger. Place the swing away pivot saddle into the receiver on the front frame tube with the leg rest facing either inward or outward from the frame (B).
3. Rotate the leg rest so that it aligns with the frame until it locks into place in the latch block (C).

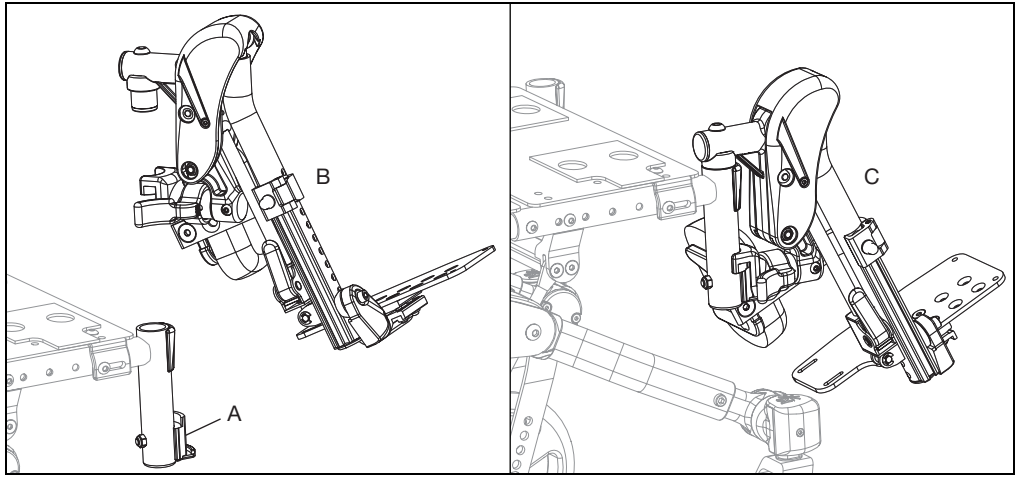

Use

1. To raise the Pediatric Pro ELR, lift the leg rest tube (B) to desired angle of elevation.
2. To lower the Pediatric Pro ELR, press and hold the lever lock (A) while pushing the leg rest tube (A) down.

NOTE: Support or remove weight from the Pediatric Pro ELR while lowering to avoid a sudden drop when the lever lock is pushed.

NOTE: The calf pad can swing outward to clear the front of the chair for transfers.

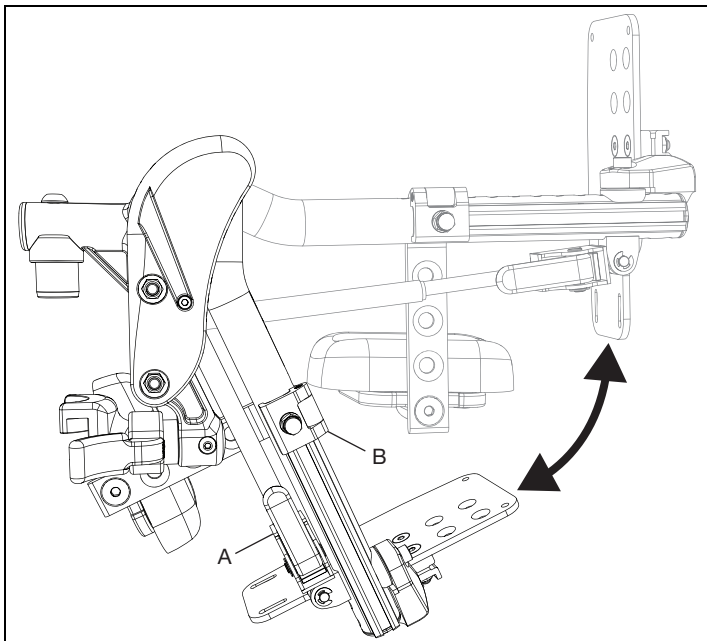

Pediatric Pro ELR

Removal (Refer to first image in Pediatric Pro ELR Section)

1. To remove leg rest, push or pull release latch.
2. Lift the leg rest straight upward to remove. You may also swing the leg rest inward or outward before lifting it off.

Adjusting Calf Pad

Adjusting Height of Calf Pad

1. Loosen nut (C) using a 10mm wrench.
2. Slide calf pad arm up or down to desired location. Retighten nut.

Adjusting Depth of Calf Pad

1. Remove screw (B) and nut (A) on calf pad arm using a 5mm Allen wrench and a 13mm wrench.
2. Pick the desired location based on the four predrilled holes and reinstall screw and nut.

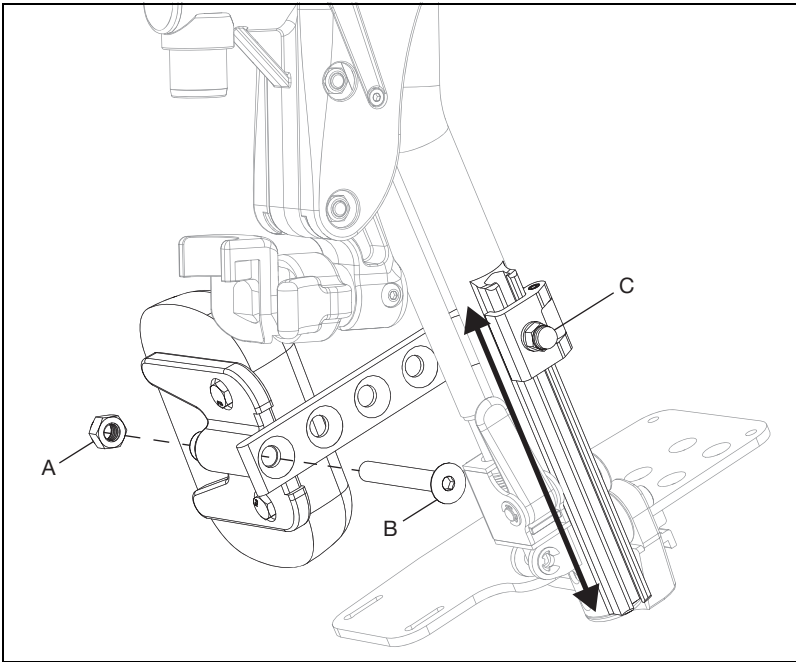

Pediatric Pro ELR

Adjusting Length of Footrest

1. Remove bolt (A), washer (B), footplate assembly (C), washer (D), saddle (E), nut (G) and ensure footrest tube insert (F) stays in tube using a 5mm Allen wrench and a 10mm wrench.
2. Move footplate to desired height and reinstall hardware to secure in the hole closest to desired height.

NOTE: Move the calf pad as needed when adjusting the length of the footrest.

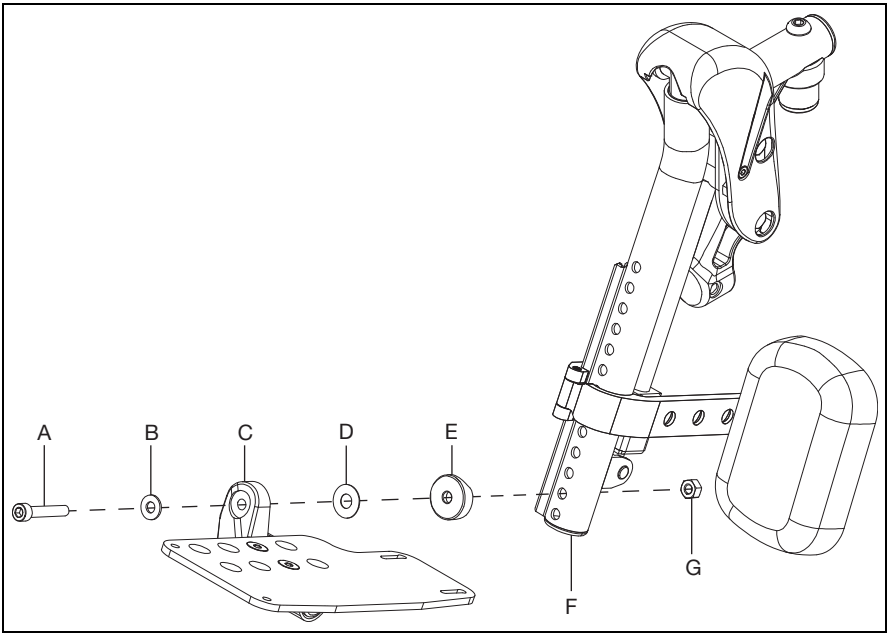

Adjusting Knee Height

1. Using two 10mm socket wrenches, loosen the two nuts (A) on the cover.
2. Adjust knee height to desired setting.
3. Retighten the two nuts (A) after desired height is attained.

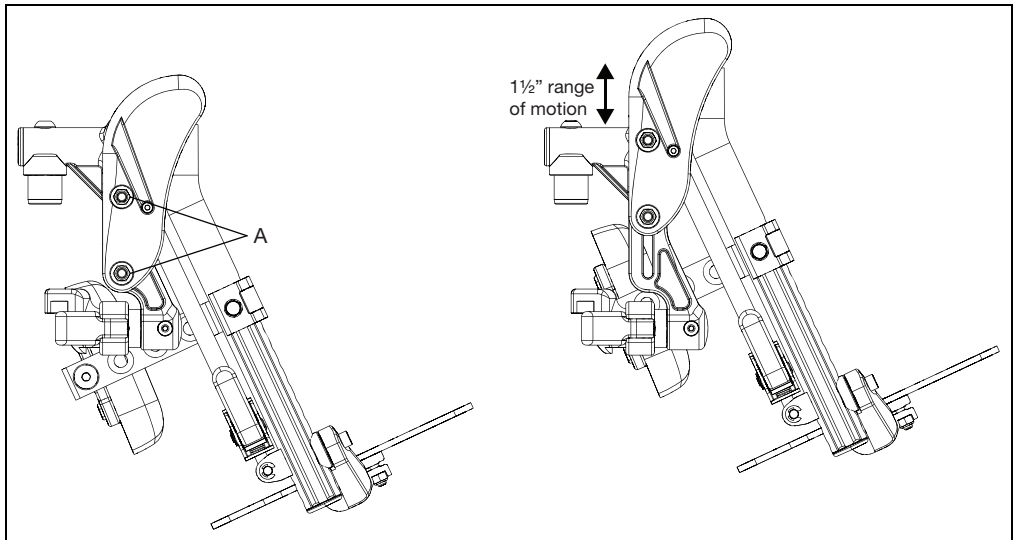

Pediatric Pro ELR

Extension Mount Configuration

Some configurations may require an extension mount to avoid interference with the footplate. Use a 5mm Allen wrench, a 4mm Allen wrench and a 10mm wrench to attach your footplate to the extension mount and the extension mount to the hanger assembly. Extension mount hardware is included in a separate bag.

NOTE: The footrest tube insert is not used when the extension mount is used and the hardware for attaching is different. See figure below for parts diagram (Not all parts are sold individually, refer to parts manual for additional information at www.kimobility.com) and the part description chart below (the rest of the assembly is shown on the next pages).

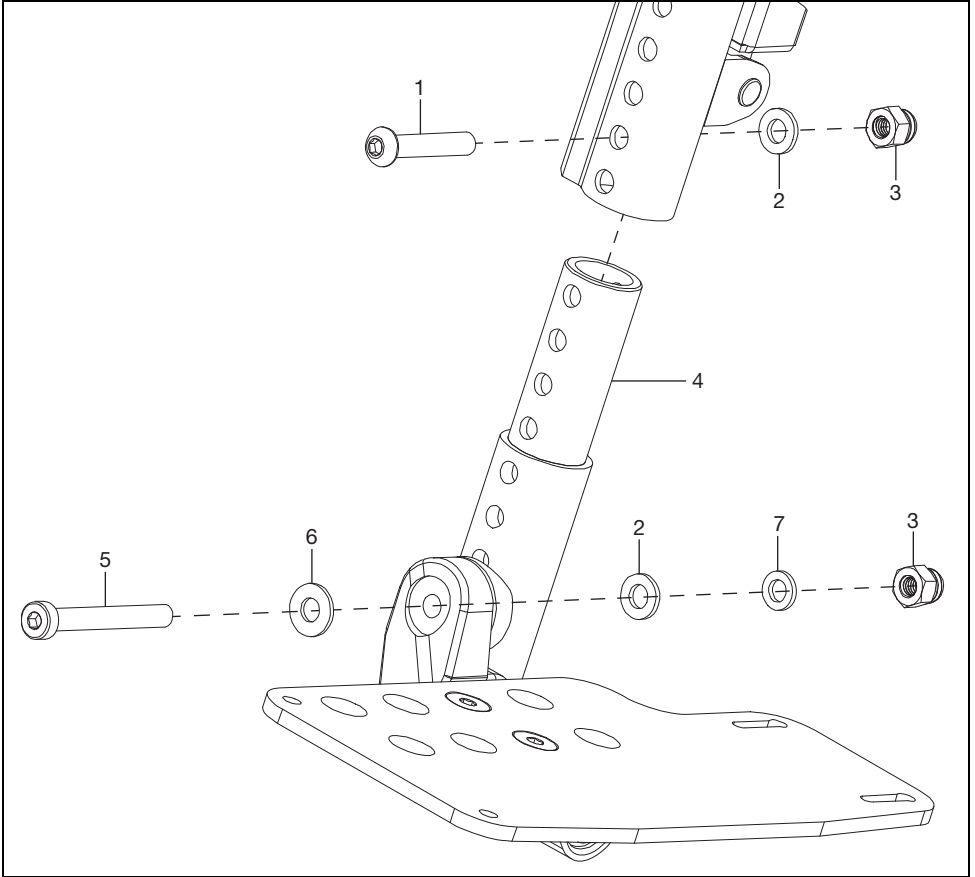

Item Number	Part Number	Description	Quantity
1	101811	BHCS, M6x1.0x35, CL10.9, BLZ, DIN7380	1
2	100746	WASHER, FLAT, M6, BLZ, DIN125A	2
3	100558	NUT, HEX, M6x1.0, DOME, CLS6, BLZ, DIN986	2
4	000164	Hanger Extension - 3"	1
5	101124	SHCS, LOW, M6x1.0x50, CL8.8, BLZ, DIN7984	1
6	101455	M6 BELLEVILLE WASHER	1
7	102072	WASHER NYLON .234IDx.406ODx.062 THICK	1

Pediatric Pro ELR

Replacing Pediatric Pro Elevated Leg Rest Parts

1. See figure below for a parts diagram of the Pediatric Pro ELR (Not all parts are sold individually, refer to parts manual for additional information at www.kimobility.com).

NOTE: Parts chart located on next page.

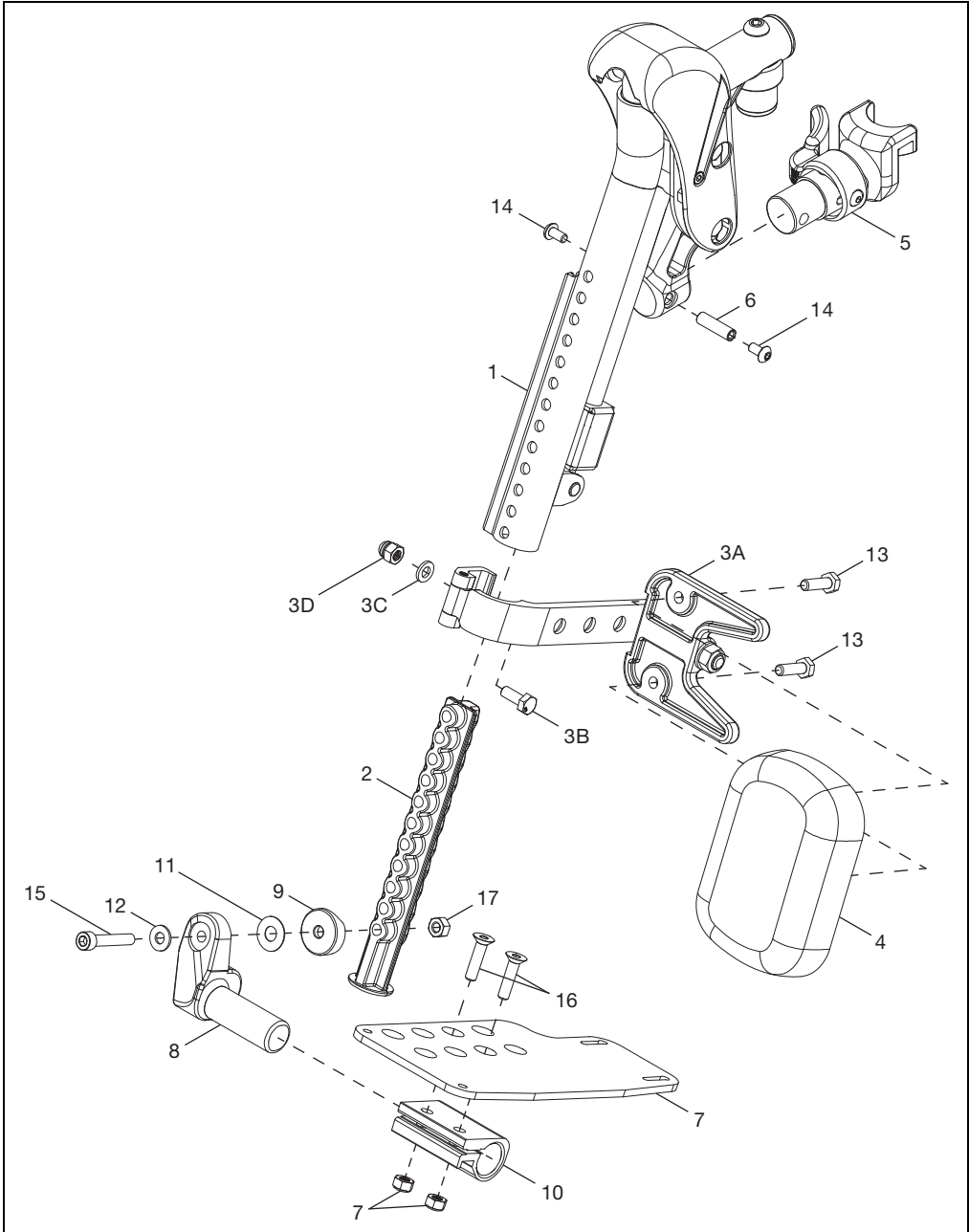

Pediatric Pro ELR

Item Number	Part Number	Description	Quantity
1	003853	Hanger Assy, Pro ELR, FM, R	1
	003854	Hanger Assy, Pro ELR, FM, L	1
2	003843	Insert, Footrest Tube	1
3	003344	Calf Pad Bracket Assembly	1
4	101585	Calf Pad - Large	1
	101470	Calf Pad Pediatric - Medium	1
	003844	Calf Pad, 84mm X 120mm - Small	1
5	003643	Hanger Latch Assy, 4-Way, L	1
	003642	Hanger Latch Assy, 4-Way, R	1
	003416	Hanger Latch Assy, R	1
	003416	Hanger Latch Assy, L	1
6	000073	M5 Threaded Barrel	1
7	001304 - 001307, 000105 - 000110	Footplate, Aluminum Angle Adj, 10-11W - 18-20W, L/R	1
8	000048	Footplate Angle Adj Casting, 1", R	1
	000050	Footplate Angle Adj Casting, 1", L	1
9	003845	Saddle, 1", Rounded	1
10	100502	Angle Adj Footrest Clamp, 2"	1
11	000428	Wear Washer	1
12	101455	M6 Belleville Washer	1
13	101823	HHCS, M6X1.0X20, CLS10.9, NYL, BLZ, DIN933	2
14	100669	BHCS, M5X0.8X10, CLS10.9, BLZ, NYL, ISO7380	2
15	101810	SHCS, M6X1.0X35, CLS12.9, BLZ, DIN912	1
16	100662	FHCS, M6X1.0X25, CLS10.9, BLZ, DIN799 1	2
17	101456	M6 DIN980 CLS8 OVL TOP L/N ZC	1
18	100658	M6 Nylock Nut, BLK ZN	2

Canopy

Installation

1. Install tube mount (C), inner clamp (B), outer clamp (D), barrel nut (A), spherical washer (E) and bolt (F) onto backrest tube using a 5mm Allen wrench. Repeat on opposite side.

NOTE: The clamps may need to be rotated to accommodate the chair width while remaining in the correct distance for the stems. See the chart below if a different canopy size is needed.

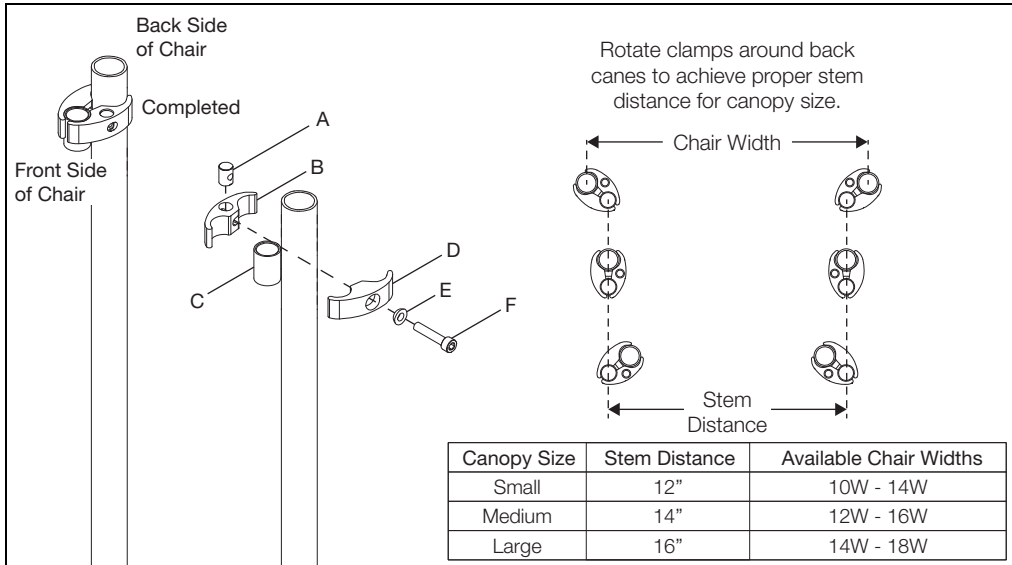

2. Drop the canopy assembly stems into the tube mounts. Ensure latch catches to secure the canopy assembly in the tube mounts. For rain, ensure the fabric around the edge is folded to create the channel which catches water and dispenses it behind the chair.

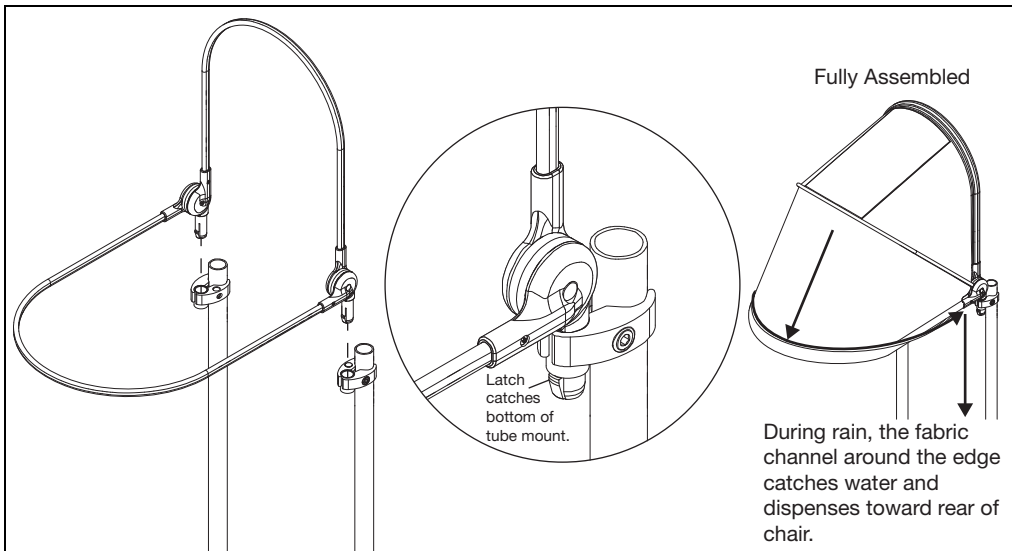

Canopy

3. To remove just the canopy, push in the latch on both stems and lift up and out of tube mount.

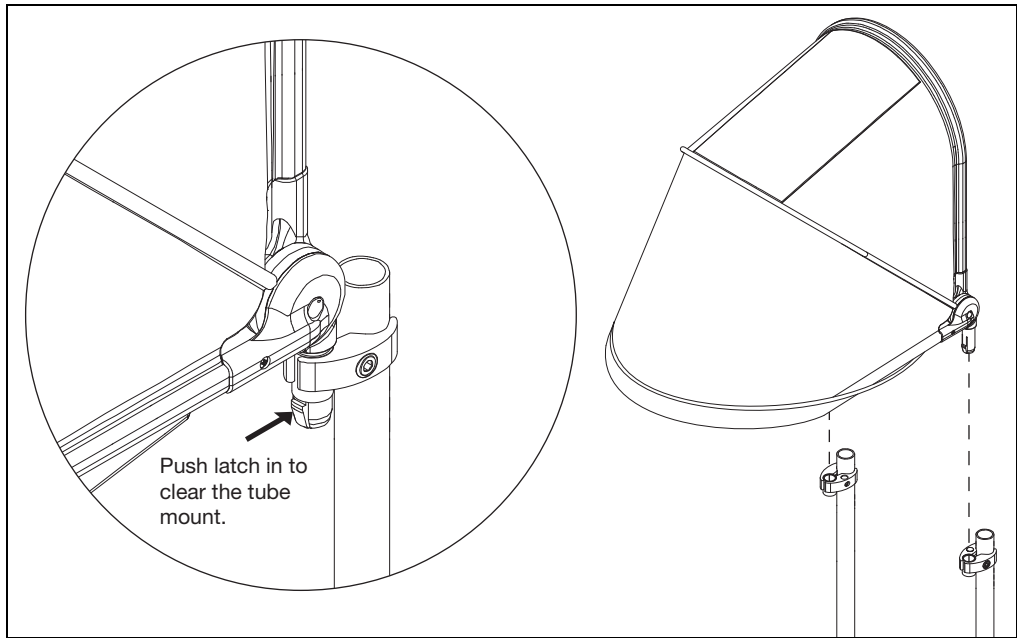



Ki Mobility
5201 Woodward Drive
Stevens Point, Wisconsin 54481
715-254-0991
www.kimobility.com



DCN0340.2