

FOCUS *CR*

FOOT TILT ADJUSTMENT GUIDE



Objective - Foot Tilt (Locked)

Lower linkage is locked and rests against the tilt stop. Linkage cannot move. Cog is engaged in the rotary frame teeth. Tilt system is locked.

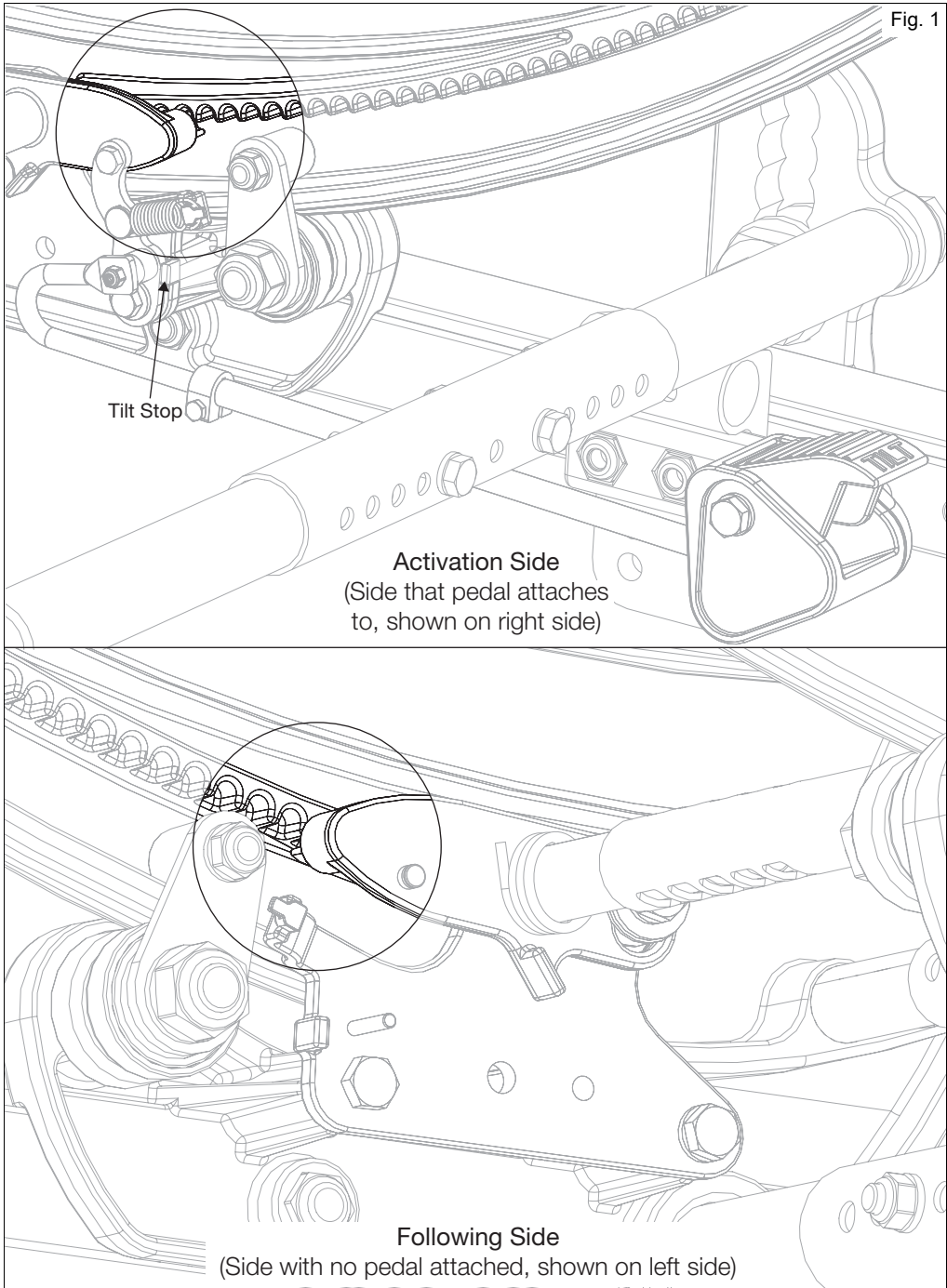

Objective - Foot Tilt (Unlocked)

When foot pedal is depressed, the foot linkage rod pulls the pivot point and spring is overcome allowing linkage to pull the cog down and disengage from the rotary frame teeth. Note the lower linkage is pulled away from the tilt stop. Tilt system is unlocked, cog has clearance from teeth.

Fig. 2

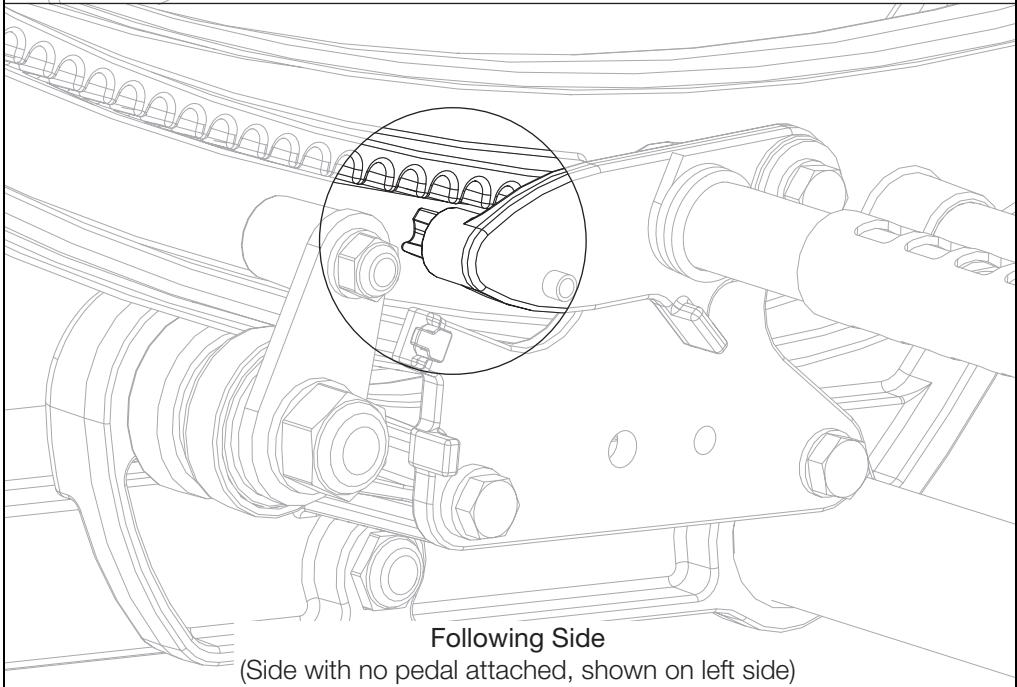
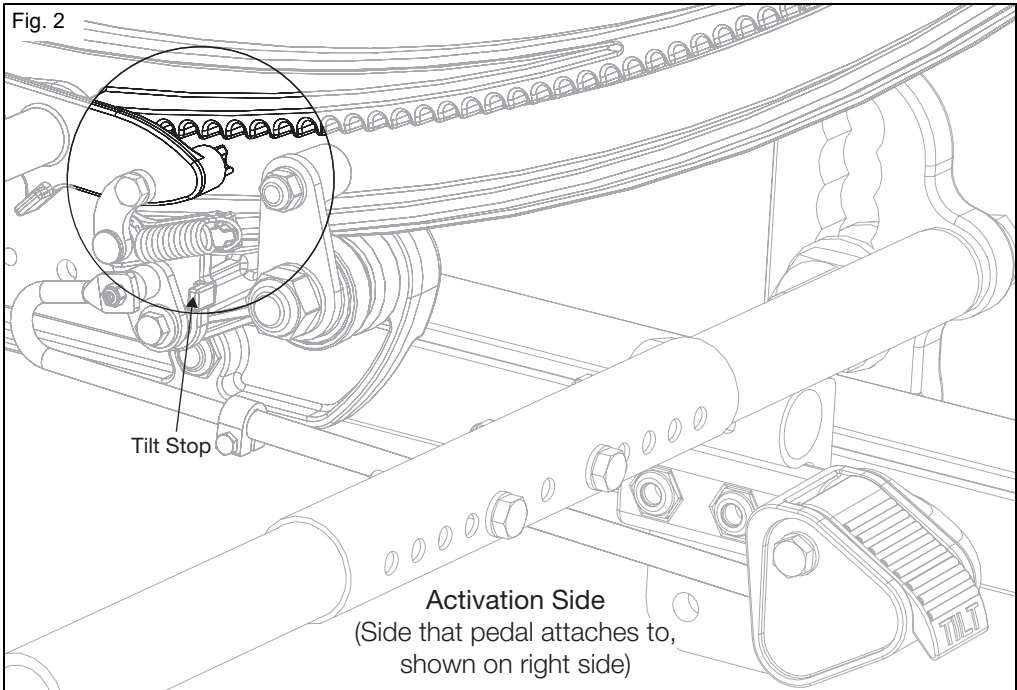

Symptoms

1. Clicking Noise

A clicking noise is heard during the action of tilting the chair. This is caused by the cog not being fully retracted. Clicking is caused by incorrect shaft clamp placement or the foot pedal not being depressed fully. This may occur on one or both sides.

Fig. 3

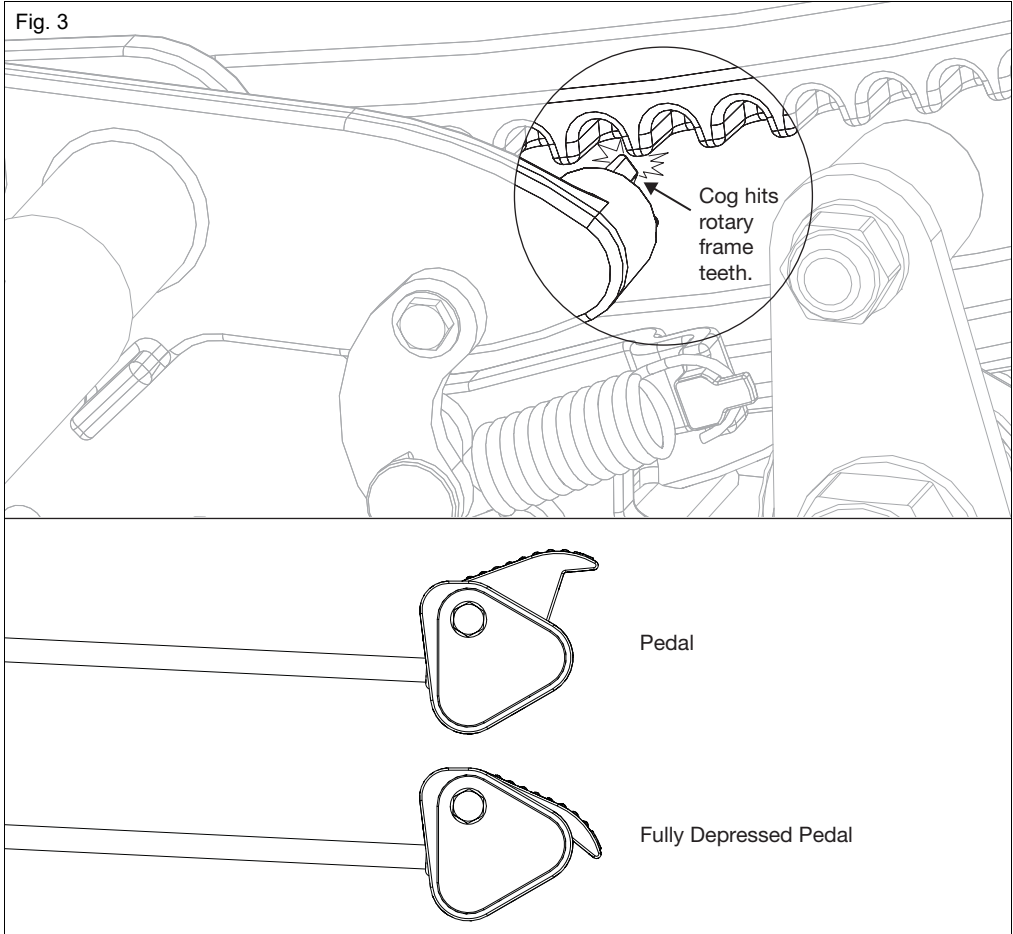

2. Tilt Not Locking / Difficulty Unlocking Tilt Mechanism

Chair may seem difficult to start and end the tilting process. It may take some wiggling to lock/unlock the tilt mechanism. This is caused by:

1. Improper bolt tightening (See Fig. 4 for image of issue. See Potential Solution - Section B for correcting)
2. Incorrect shaft clamp placement (See Fig. 5 for image of issue. See Potential Solution - Section A for correcting)
3. Improper drive insert issues (See Potential Solution - Section C for correcting)
4. COG adjustment being needed (See Potential Solution - Section D for correcting)

Symptoms

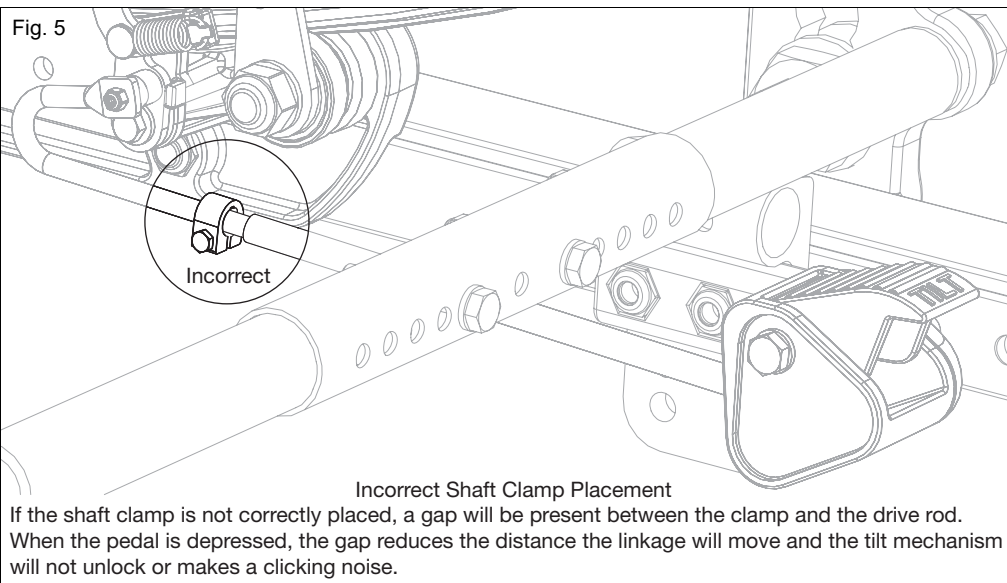
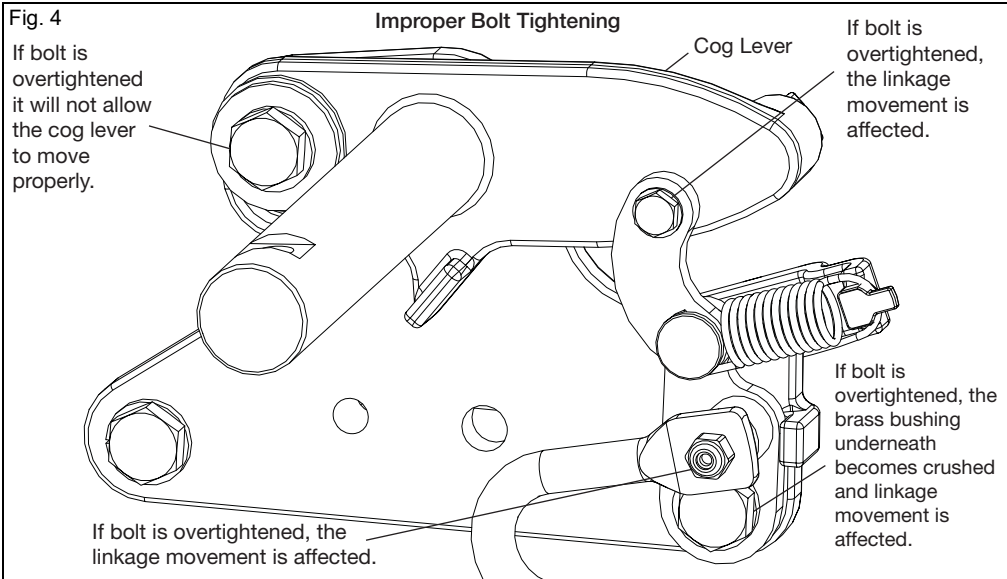

3. Tilt Mechanism Won't Lock / Locks Intermittently

The tilt mechanism may not lock at all or occasionally catches and locks. This could be caused by the drive rod being too slack (See Fig. 5 for image of issue. See Potential Solution - Section A for correcting) or improper bolt tightening (See Fig. 4 for image of issue. See Potential Solution - Section B for correcting).

4. One Side of Tilt Mechanism Sticks

One side of the tilt mechanism may seem to catch and or not start/end tilt process as smoothly as the opposite side. This is caused by improper bolt tightening ((See Fig. 4 for image of issue. See Potential Solution - Section B for correcting) or improper drive insert issues (See Potential Solution - Section C for correcting).

Potential Solutions

A. Incorrect Shaft Clamp Placement

Before beginning adjustment, ensure tilt mechanism is locked and engaged. Adjust the locking clamp by loosening Allen head screw or hex bolt (C) on the shaft clamp (A) with either a 2.5mm Allen wrench or a 5.5mm wrench. Slide the shaft clamp up against the drive rod linkage (B) and retighten the shaft clamp. If clamp is slipping after adjusting and tightening, contact customer service.

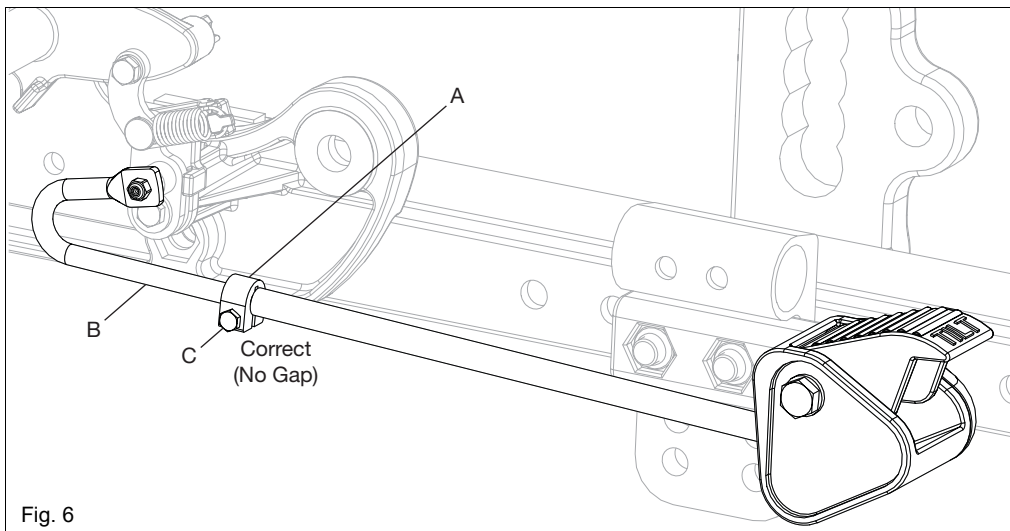

B. Improper Bolt Tightening

Bolts A, B, C and E should be tightened snug. Bolt D should be fully tightened. Inspect the following - nylon washers under bolt E ensuring washer is intact and linkage system is free moving. Release linkage spring and confirm. If it is stiff at the bottom linkage, replace brass bushing under bolt B. Also, check the tightness of bolt C if linkage movement is restricted. Also check bolts B, D and E on the opposite side. Replace any parts that appear crushed, cracked or broken.

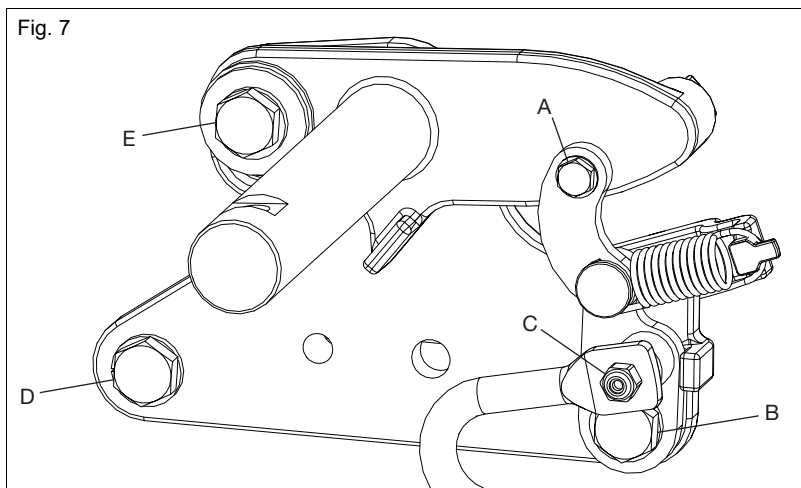

Potential Solutions

C. Improper Drive Insert

Ensure the long end of drive insert on the **top** of the strut tube is facing the front of the chair. The long end of the drive insert on the **bottom** of strut tube should be facing the rear of the chair (opposite of the top drive insert).

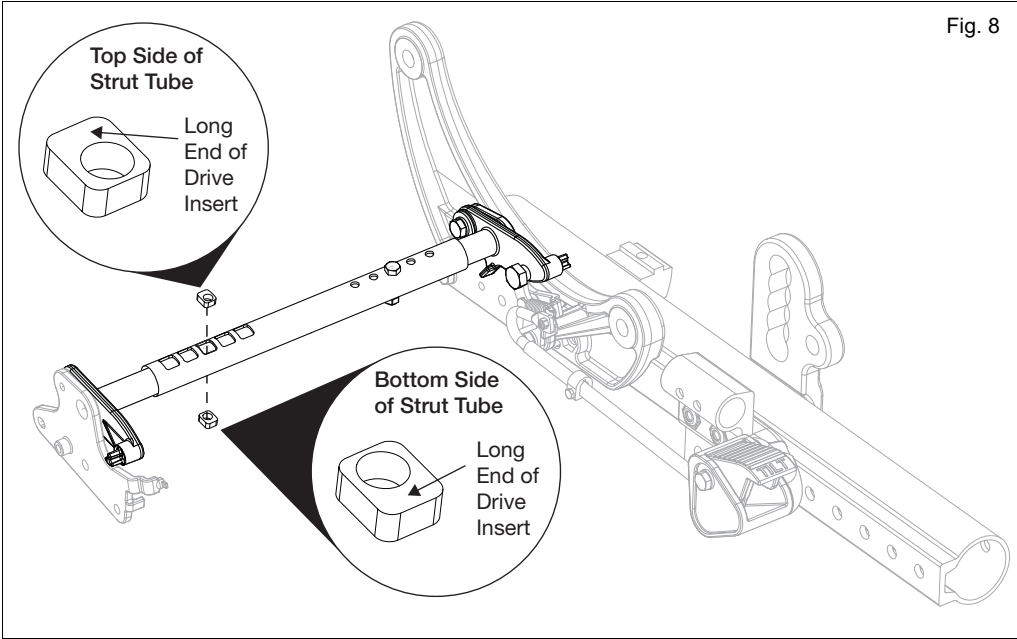

Potential Solutions

D. COG Adjustment

To correct a COG adjustment issue, follow the diagram, table and instructions below to correct.

- Remove the seat frame position locking screws (B) using a 5mm Allen wrench.
- If resting angle is larger than 23°, pull seat frame toward the front of the chair until approximate 20° resting angle is achieved. If frame rests at an angle smaller than 17°, push seat frame toward the rear until approximate 20° is achieved.
- Different occupants will respond differently, but a good starting point is to move the seat frame ½" for every 5° that the angle is off from 20°.
- Once optimum position is achieved, reinstall and tighten positioning screws in holes closest to optimum position. Screws may be placed in front or rear hole of seat frame saddle (A).

Fig. 9

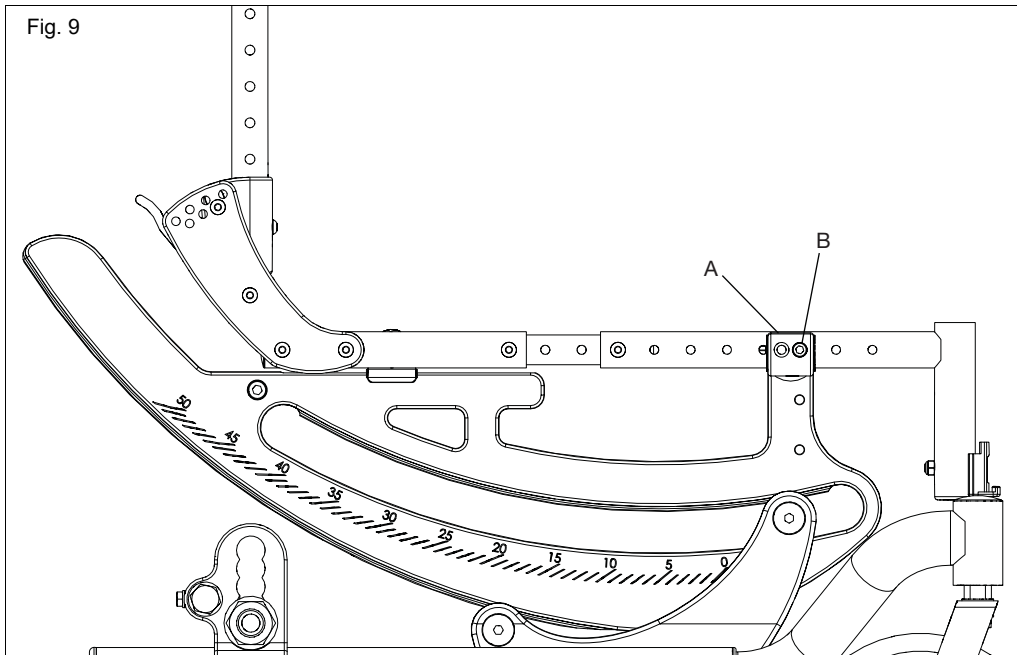

System Resting Position	Adjustment Required
System Rests Between 50 and 45	3 Holes Forward
System Rests Between 44 and 35	2 Holes Forward
System Rests Between 34 and 25	1 Hole Forward
System Rests Between 24 and 16	Acceptable
System Rests Between 15 and 7	1 Hole Rearward
System Rests Between 6 and -2	2 Holes Rearward
System Rests Between -3 and -5	3 Holes Rearward

*System Includes Seating and End User

Additional Help

For part information and ordering visit www.kimobility.com or call 715-254-0991.

Always have the user read the entire owner's manual. BEFORE riding, the user should be trained in the safe use of this chair by an Assistive Technology Practitioner (ATP) or clinical professional.

If you have any questions or concerns about any aspect of this wheelchair, please do not hesitate to contact us

